

Transportstyrelsens föreskrifter och allmänna råd om säkerheten på höghastighetsfartyg (HSC-koden 2000) (konsoliderad elektronisk utgåva)

beslutade den 14 oktober 2009. Ändringar införda t.o.m TSFS 2023:58.

Den konsoliderade elektroniska utgåvan kan innehålla fel. Observera därför att det alltid är den tryckta utgåvan som gäller.

Innehåll

Transportstyrelsens föreskrifter och allmänna råd om säkerheten på höghastighetsfartyg (HSC-koden 2000).....	1
Bilaga 1 – International Code of Safety for High-Speed Craft, 2000	5
Bilaga 2 – Resolutioner.....	321
Bilaga 3 – Cirkulär	321

Transportstyrelsens föreskrifter och allmänna råd om säkerheten på höghastighetsfartyg (HSC-koden 2000) (konsoliderad elektronisk utgåva);

TSFS 2009:102

Konsoliderad elektronisk
utgåva

SJÖFART

beslutade den 14 oktober 2009. Ändringar införda t.o.m TSFS 2023:58.

Den konsoliderade elektroniska utgåvan kan innehålla fel. Observera därför att det alltid är den tryckta utgåvan som gäller.

1 § Svenska fartyg och utländska fartyg på svenskt sjöterritorium med byggnadsdatum den 1 juli 2002 eller senare ska, om inget annat anges, för att äga rätt till ett höghastighetsfartygscertifikat, uppfylla koden för höghastighetsfartyg (International Code of Safety for High-Speed Craft, 2000 (HSC-koden 2000)) som antogs av den internationella sjöfartsorganisationen (IMO) den 5 december 2000 genom resolution MSC.97(73)¹, i den utsträckning som anges i koden.

Resolutioner, cirkulär och standarder som nämns i eller hänvisas till i kodens text ska tillämpas som svenska föreskrifter.

Kodens konsoliderade text på engelska finns i bilaga 1 till dessa föreskrifter. De gällande ändringarna av koden finns också i bilaga 2 till dessa föreskrifter.

Den engelska, arabiska, franska, kinesiska, ryska och spanska texten av koden ska ha samma giltighet.²

Allmänna råd

<i>Vid tillämpning av</i>	<i>bör nedanstående tillämpas</i>
<i>HSC-koden 2000</i>	<i>tolkningarna i MSC/Circ.1102³, om inte annat anges nedan</i>
<i>HSC-koden 2000, kapitel 7</i>	<i>MSC/Circ.912⁴</i>
<i>HSC-koden 2000, regler i 4.8.2</i>	<i>MSC/Circ.1166⁵</i>

¹ MSC.97(73), Adoption of the International Code of Safety for High-Speed Craft, 2000 (2000 HSC Code).

² De angivna språkversionerna finns tillgängliga hos IMO.

³ MSC/Circ.1102, Interpretations of the 2000 HSC Code and SOLAS Chapter X.

⁴ MSC/Circ.912, Interpretations of Standards for Fixed Sprinkler Systems for High-Speed Craft (Resolution MSC.44(65)).

<i>Vid tillämpning av</i>	<i>bör nedanstående tillämpas</i>
<i>HSC-koden 2000, regel 9.1.5</i>	<i>MSC/Circ.1177⁶</i>
<i>ev. testförfarande enligt HSC-koden, regel 2.2.3.2.2</i>	<i>MSC/Circ.1195⁷</i>
<i>HSC-koden 2000, kapitel 7</i>	<i>MSC.1/Circ.1457⁸</i>
<i>HSC-koden 2000, kapitel 1</i>	<i>MSC.1/Circ.1542⁹</i>

*De cirkulär som anges ovan finns i bilaga 3 till dessa föreskrifter.
(TSFS 2023:58)*

2 § Med ett fartygs byggnadsdatum menas det datum då fartyget kölsträcks eller befinner sig på ett motsvarande byggnadsstadium; motsvarande byggnadsstadium innebär att byggnation som kan identifieras till ett enskilt fartyg har påbörjats och sammansättning av detta fartyg har nått en omfattning av minst 50 ton, eller 3 % av den uppskattade totalvikten av allt material som ingår i fartygets struktur, om det är mindre.

3 § Tekniska krav i dessa föreskrifter gäller inte för ett fartyg eller dess utrustning om fartyget eller utrustningen

- lagligen har tillverkats eller har satts på marknaden i en annan medlemsstat inom EU eller i Turkiet, eller
- lagligen har tillverkats i ett EFTA-land som har undertecknat EES-avtalet.

Om fartyg eller utrustning enligt första stycket inte uppnår en säkerhetsnivå som är likvärdig med den som garanteras genom dessa föreskrifter, ska de tekniska kraven i dessa föreskrifter gälla.

4 § Utrustning som installeras eller placeras på fartyg som omfattas av dessa föreskrifter ska, om utrustningen omfattas av lagen (2016:768) om marin utrustning uppfylla kraven i den lagen och föreskrifter meddelade i anslutning till lagen, om inget anges i dessa föreskrifter eller om Transportstyrelsen i enskilt fall inte beslutar annat. (TSFS 2016:91)

5 § Fartyg som är certifierade enligt dessa föreskrifter anses uppfylla kraven i kapitel I-IV¹⁰ och reglerna 18–20 i kapitel V¹¹ i 1974 års internationella konvention om säkerheten för människoliv till sjöss (SOLAS 1974) samt lastlinjekonventionen med tillhörande protokoll.^{12, 13}

⁵ MSC/Circ.1166, Guidelines for a Simplified Evacuation Analysis for High-Speed Passenger Craft.

⁶ MSC/Circ.1177, Unified Interpretation of the 2000 HSC Code.

⁷ MSC.1/Circ.1195, Guidelines for the Conduct of High Speed Craft Model Tests.

⁸ MSC.1/Circ.1457, Unified Interpretation of the 2000 HSC Code, as amended by resolutions MSC.175(79) and MSC.222(82).

⁹ MSC.1/Circ.1542, Unified Interpretation of the 2000 HSC Code.

¹⁰ SJÖFS 2006:1, TSFS 2009:1, TSFS 2009:2, TSFS 2009:93, TSFS 2009:95 och TSFS 2009:98.

¹¹ SJÖFS 2006:17.

¹² SJÖFS 2006:1.

6 § Fartyg som omfattas av dessa föreskrifter och som genomgår reparationer, förändringar, modifikationer och utrustas i samband därmed ska efter dessa åtgärder åtminstone uppfylla de krav som tidigare gällt för fartyget.

7 § Transportstyrelsen kan, om det finns särskilda skäl, medge undantag från dessa föreskrifter.

TSFS 2009:102

1. Denna författning träder i kraft den 1 januari 2010.

2. Fartyg med byggnadsdatum från och med den 1 juli 2002 till den 1 juli 2008 ska endast tillämpa regel 1.8.1, 1.9.1.1, 2.7.2, 7.17, 13.8.2 samt 14.15.10 i bilaga 1 till dessa föreskrifter. I övriga delar ska bilaga 1 till Sjöfartsverkets föreskrifter och allmänna råd (SJÖFS 2003:12) om säkerheten på höghastighetsfartyg (HSC-koden 2000) tillämpas.

3. Sjöfartsverkets och Transportstyrelsens beslut som gäller då denna författning träder i kraft, gäller även efter ikraftträdandet av denna författning. Sådana beslut ska anses ha meddelats av Transportstyrelsen och gäller till dess Transportstyrelsen meddelar ett nytt beslut eller giltighetstiden för beslutet går ut.

4. Om det i en föreskrift som har beslutats av Sjöfartsverket hänvisas till Sjöfartsverkets föreskrifter och allmänna råd (SJÖFS 2003:12) om säkerheten på höghastighetsfartyg (HSC-koden 2000) ska denna hänvisning istället avse dessa föreskrifter.

TSFS 2011:89

Denna författning träder i kraft den 1 juli 2012.

TSFS 2016:91

Denna författning träder i kraft den 18 september 2016.

TSFS 2023:58

Denna författning träder i kraft den 1 januari 2023.

¹³ MSC/Circ.1028, Application of the International Convention on Load Lines, 1966 and the 1988 Protocol relating thereto, to High Speed Craft.

Bilaga 1

**INTERNATIONAL CODE OF SAFETY
FOR HIGH-SPEED CRAFT, 2000**

**INTERNATIONAL CODE OF SAFETY
FOR HIGH-SPEED CRAFT, 2000**

CONTENTS

1.1	General Comments	16
1.2	General requirements.....	16
1.3	Application	17
1.4	Definitions	19
1.5	Surveys	25
1.6	Approvals	27
1.7	Maintenance of conditions after survey.....	27
1.8	High-Speed Craft Safety Certificate.....	28
1.9	Permit to Operate High-Speed Craft.....	30
1.10	Control.....	32
1.11	Equivalents	32
1.12	Information to be made available	32
1.13	Further developments	32
1.14	Circulation of safety information.....	33
1.15	Review of the Code	33
	PART A - GENERAL	34
2.1	General	34
2.2	Intact buoyancy and watertight and weathertight integrity.....	36
2.3	Intact stability in the displacement mode	46
2.4	Intact stability in the non-displacement mode	47
2.5	Intact stability in the transitional mode.....	48
2.6	Buoyancy and stability in the displacement mode following damage	48
2.7	Inclining and stability information	56
2.8	Loading and stability assessment.....	57
2.9	Marking and recording of the design waterline	57
	PART B - REQUIREMENTS FOR PASSENGER CRAFT	59
2.10	General	59
2.11	Intact stability in the displacement mode	60
2.12	Intact stability in the non-displacement mode	60
2.13	Buoyancy and stability in the displacement mode following damage	60
2.14	Inclining and stability information	61
	PART C - REQUIREMENTS FOR CARGO CRAFT.....	62
2.15	Buoyancy and stability in the displacement mode following damage	62
2.16	Inclining	62
3.1	General	63
3.2	Materials.....	63
3.3	Structural strength	63
3.4	Cyclic loads	63
3.5	Design criteria	63

3.6	Trials.....	64
4.1	General	65
4.2	Public address and information system	65
4.3	Design acceleration levels	66
4.4	Accommodation design.....	69
4.5	Seating construction	71
4.6	Safety belts	71
4.7	Exits and means of escape.....	71
4.8	Evacuation time.....	74
4.9	Baggage, stores, shops and cargo compartments.....	77
4.10	Noise levels	78
4.11	Protection of the crew and passengers.....	78
5.1	General	79
5.2	Reliability	79
5.3	Demonstrations.....	80
5.4	Control position.....	80
6.1	General	81
6.2	Anchoring.....	81
6.3	Towing	82
6.4	Berthing.....	82
	PART A - GENERAL	83
7.1	General Requirements	83
7.2	Definitions	84
7.3	Classification of space use.....	85
7.4	Structural fire protection.....	89
7.5	Fuel and other flammable fluid tanks and systems	96
7.6	Ventilation.....	98
7.7	Fire detection and extinguishing systems	100
7.8	Protection of special category spaces and ro-ro spaces	113
7.9	Miscellaneous.....	117
7.10	Firefighter's outfits	120
	PART B - REQUIREMENTS FOR PASSENGER CRAFT..	122
7.11	Arrangement.....	122
7.12	Ventilation.....	122
7.13	Fixed sprinkler system.....	123
	PART C - REQUIREMENTS FOR CARGO CRAFT.....	123
7.14	Control stations.....	123
7.15	Cargo spaces.....	124
7.16	Fixed sprinkler system.....	124
	PART D - REQUIREMENTS FOR CRAFT AND CARGO SPACES INTENDED FOR THE CARRIAGE OF DANGEROUS GOODS.....	124
7.17	General	124
8.1	General and definitions.....	136
8.2	Communications.....	139
8.3	Personal life-saving appliances.....	140

8.4	Muster list, emergency instructions and manuals	141
8.5	Operating instructions	142
8.6	Survival craft stowage	142
8.7	Survival craft and rescue boat embarkation and recovery arrangements	144
8.8	Line-throwing appliance.....	145
8.9	Operational readiness, maintenance and inspections.....	145
8.10	Survival craft and rescue boats.....	150
8.11	Helicopter pick-up areas.....	151
	PART A - GENERAL	152
9.1	General	152
9.2	Engine (general)	154
9.3	Gas turbines.....	155
9.4	Diesel engines for main propulsion and essential auxiliaries	156
9.5	Transmissions.....	157
9.6	Propulsion and lift devices	158
	PART B - REQUIREMENTS FOR PASSENGER CRAFT..	159
9.7	Independent means of propulsion for category B craft.....	159
9.8	Means for return to a port of refuge for category B craft.....	159
	PART C - REQUIREMENTS FOR CARGO CRAFT.....	159
9.9	Essential machinery and control.....	159
	PART A - GENERAL	160
10.1	General	160
10.2	Arrangement of oil fuel, lubricating oil and other flammable oil.....	161
10.3	Bilge pumping and drainage systems	164
10.4	Ballast systems	166
10.5	Cooling systems	166
10.6	Engine air intake systems	166
10.7	Ventilation systems	166
10.8	Exhaust systems	167
	PART B - REQUIREMENTS FOR PASSENGER CRAFT..	167
10.9	Bilge pumping and drainage systems	167
	PART C - REQUIREMENTS FOR CARGO CRAFT.....	168
10.10	Bilge pumping systems.....	168
11.1	Definitions	169
11.2	General	169
11.3	Emergency controls.....	169
11.4	Alarm system.....	170
11.5	Safety system.....	172
	PART A - GENERAL	173
12.1	General	173

12.2	Main source of electrical power	174
12.3	Emergency source of electrical power.....	175
12.4	Starting arrangements for emergency generating sets	177
12.5	Steering and stabilization.....	178
12.6	Precautions against shock, fire and other hazards of electrical origin	179
PART B - REQUIREMENTS FOR PASSENGER CRAFT..183		
12.7	General	183
PART C - REQUIREMENTS FOR CARGO CRAFT.....188		
12.8	General	188
13.1	General	192
13.2	Compasses.....	192
13.3	Speed and distance measurement	193
13.4	Echo-sounding device	193
13.5	Radar installations	193
13.6	Electronic positioning systems	193
13.7	Rate-of-turn indicator and rudder angle indicator	194
13.8	Nautical charts and nautical publications	194
13.9	Searchlight and daylight signalling lamp.....	194
13.10	Night vision equipment	194
13.11	Steering arrangement and propulsion indicator(s).....	194
13.12	Automatic steering aid (automatic pilot).....	195
13.13	Radar reflector.....	195
13.14	Sound reception system.....	195
13.15	Automatic identification system	195
13.16	Voyage data recorder.....	196
13.17	Approval of systems and equipment, and performance standards.....	196
14.1	Application	198
14.2	Terms and definitions	198
14.3	Exemptions.....	200
14.4	Global Maritime Distress and Safety System Identities	201
14.5	Functional requirements	201
14.6	Radio installations	202
14.7	Radio equipment: general.....	203
14.8	Radio equipment: sea area A1	204
14.9	Radio equipment: sea areas A1 and A2.....	206
14.10	Radio equipment: sea areas A1, A2 and A3	207
14.11	Radio equipment: sea areas A1, A2, A3 and A4	209
14.12	Watches	209
14.13	Sources of energy	210
14.14	Performance standards.....	211
14.15	Maintenance requirements.....	212
14.16	Radio personnel.....	214
14.17	Radio records.....	214
14.18	Position-updating.....	215
15.1	Definitions	216
15.2	General	216
15.3	Field of vision from the operating compartment	216

15.4	Operating compartment	217
15.5	Instruments and chart table.....	218
15.6	Lighting	219
15.7	Windows.....	220
15.8	Communication facilities.....	221
15.9	Temperature and ventilation.....	221
15.10	Colours	221
15.11	Safety measures.....	221
16.1	Definitions	222
16.2	General requirements.....	223
16.3	Lateral and height control systems	223
16.4	Demonstrations.....	224
17.1	General	225
17.2	Proof of compliance	225
17.3	Weight and centre of gravity	225
17.4	Effect of failures	226
17.5	Controllability and manoeuvrability.....	226
17.6	Change of operating surface and mode.....	227
17.7	Surface irregularities	227
17.8	Acceleration and deceleration.....	227
17.9	Speeds.....	227
7.10	Minimum depth of water	228
17.11	Hard structure clearance	228
17.12	Night operation.....	228
	PART A - GENERAL	229
18.1	Craft operational control.....	229
18.2	Craft documentation	231
18.3	Training and qualifications.....	236
18.4	Manning of survival craft and supervision	238
18.5	Emergency instructions and drills	238
	PART B - REQUIREMENTS FOR PASSENGER CRAFT ..242	
18.6	Type rating training	242
18.7	Emergency instructions and drills	243
	PART C - REQUIREMENTS FOR CARGO CRAFT.....243	
18.8	Type rating training	243
	ANNEX 1 FORM OF HIGH-SPEED CRAFT SAFETY CERTIFICATE AND RECORD OF EQUIPMENT	245
	ANNEX 2 FORM OF PERMIT TO OPERATE HIGH-SPEED CRAFT	257
	ANNEX 3 USE OF PROBABILITY CONCEPT	259
	ANNEX 4 PROCEDURES FOR FAILURE MODE AND EFFECTS ANALYSIS	265
	ANNEX 5 ICE ACCRETION APPLICABLE TO ALL TYPES OF CRAFT	279
	ANNEX 6 STABILITY OF HYDROFOIL CRAFT	283

TSFS 2009:102

Bilaga 1

ANNEX 7 STABILITY OF MULTIHULL CRAFT	289
ANNEX 8 STABILITY OF MONOHULL CRAFT	295
ANNEX 9 DEFINITIONS, REQUIREMENTS AND COMPLIANCE CRITERIA RELATED TO OPERATIONAL AND SAFETY PERFORMANCE.....	299
ANNEX 10 CRITERIA FOR TESTING AND EVALUATION OF SEATS.....	305
ANNEX 11 OPEN REVERSIBLE LIFERAFTS	311
FACTORS TO BE CONSIDERED IN DETERMINING CRAFT	319
OPERATING LIMITATIONS.....	319

INTERNATIONAL CODE OF SAFETY FOR HIGH-SPEED CRAFT, 2000

Preamble

1 The international conventions ratified in respect of conventional ships and the regulations applied as a consequence of such conventions have largely been developed having in mind the manner in which conventional ships are constructed and operated. Traditionally, ships have been built of steel and with the minimum of operational controls. The requirements for ships engaged on long international voyages are therefore framed in such a way that, providing the ship is presented for survey and a Ship Safety Certificate is issued, the ship may go anywhere in the world without any operational restrictions being imposed. Providing the ship is not involved in a casualty, all that is needed is that it is made available to the Administration for the purpose of a satisfactory resurvey before the Ship Safety Certificate expires and the Certificate will be reissued.

2 The traditional method of regulating ships should not be accepted as being the only possible way of providing an appropriate level of safety. Nor should it be assumed that another approach, using different criteria, could not be applied. Over a long period of time, numerous new designs of marine vehicles have been developed and have been in service. While these do not fully comply with the provisions of the international conventions relating to conventional ships built of steel, they have demonstrated an ability to operate at an equivalent level of safety when engaged on restricted voyages under restricted operational weather conditions and with approved maintenance and supervision schedules.

3 The High-Speed Craft Code 1994 (1994 HSC Code) was derived from the previous Code of Safety for Dynamically Supported Craft (DSC Code) adopted by IMO in 1977, recognizing that safety levels can be significantly enhanced by the infrastructure associated with regular service on a particular route, whereas the conventional ship safety philosophy relies on the ship being self-sustaining with all necessary emergency equipment being carried on board.

4 The safety philosophy of this Code is based on the management and reduction of risk as well as the traditional philosophy of passive protection in the event of an accident. Management of risk through accommodation arrangement, active safety systems, restricted operation, quality management and human factors engineering should be considered in evaluating safety equivalent to current conventions. Application of mathematical analysis should be encouraged to assess risk and determine the validity of safety measures.

5 This Code takes into account that a high-speed craft is of a light displacement compared with a conventional ship. This displacement aspect is the essential parameter to obtain fast and competitive sea transportation and consequently this Code allows for use of non-conventional shipbuilding

materials, provided that a safety standard at least equivalent to conventional ships is achieved.

6 To clearly distinguish such craft, criteria based on speed and volumetric Froude number have been used to delineate those craft to which this Code applies from other, more conventional, craft.

7 The Code requirements also reflect the additional hazards which may be caused by the high speed compared with conventional ship transportation. Thus, in addition to the normal requirements (including life-saving appliances, evacuation facilities, etc.) provided in case of an accident occurring, further emphasis is placed on reducing the risk of hazardous situations arising. Some advantages result from the high-speed craft concept, i.e. the light displacement provides a large reserve buoyancy in relation to displacement, reducing the hazards addressed by the International Convention on Load Lines, 1966. The consequences of other hazards, such as of collision at high speed, are balanced by more stringent navigational and operational requirements and specially developed accommodation provisions.

8 The above-mentioned safety concepts were originally reflected in the DSC Code and in the 1994 HSC Code. The development of novel types and sizes of craft has led to the development of pressures within the maritime industry for craft which are not dynamically supported cargo craft or passenger craft carrying larger numbers of passenger or operating further afield than permitted by that Code to be certified according to those concepts. Additionally, improvements of maritime safety standards since 1994 were required to be reflected in the revisions of the 1994 HSC Code to maintain safety equivalence with conventional ships.

9 Accordingly, two differing principles of protection and rescue were embodied in the 1994 HSC Code.

10 The first of these recognizes the craft which were originally foreseen at the time of development of the DSC Code. Where rescue assistance is readily available and the total number of passengers is limited, a reduction in passive and active protection may be permitted. Such craft are called "assisted craft" and form the basis for "category A passenger craft" of this Code.

11 The second concept recognizes the further development of high-speed craft into larger craft. Where rescue assistance is not readily available or the number of passengers is unlimited, additional passive and active safety precautions are required. These additional requirements provide for an area of safe refuge on board, redundancy of vital systems, increased watertight and structural integrity and full fire-extinguishing capability. Such craft are called "unassisted craft" and form the basis for "cargo craft" and "category B passenger craft" of this Code.

12 These two concepts have been developed as a unified document on the basis that an equivalent level of safety to that normally expected on ships

complying with the International Convention for the Safety of Life at Sea, 1974 is achieved. Where the application of new technology or design indicates an equivalent safety level to the strict application of this Code, the Administration is permitted to formally recognize such equivalence.

13 It is important that an Administration, in considering the suitability of a high-speed craft under this Code, should apply all sections of the Code because non-compliance with any part of the Code could result in an imbalance which would adversely affect the safety of the craft, passengers and crew. For a similar reason, modifications to existing craft, which may have an effect on safety, should be approved by the Administration.

14 In developing this Code, it has been considered desirable to ensure that high-speed craft do not impose unreasonable demands on existing users of the environment or conversely suffer unnecessarily through lack of reasonable accommodation by existing users. Whatever burden of compatibility there is, it should not necessarily be laid wholly on the high-speed craft.

15 Paragraph 1.15.1 of the 1994 HSC Code states that it should be reviewed by the Organization at intervals preferably not exceeding 4 years to consider revision of existing requirements to take account of new developments in design and technology. Experience gained with the application of the 1994 HSC Code since it entered into force in 1996 has led to the recognition that it needed to be revised and updated. Subsequent work in the Organization has resulted in the development of the present Code to ensure that safety is not compromised as a result of continuous introduction of state-of-the-art technology and innovative developments into the new and generally much larger and faster high-speed craft.

CHAPTER 1

General Comments and Requirements

1.1 General Comments

This Code shall be applied as a complete set of comprehensive requirements. It contains requirements for the design and construction of high-speed craft engaged on international voyages, the equipment which shall be provided and the conditions for their operation and maintenance. The basic aim of the Code is to set levels of safety which are equivalent to those of conventional ships required by the International Convention for the Safety of Life at Sea, 1974, as amended, (SOLAS Convention) and the International Convention on Load Lines, 1966, (Load Line Convention) by the application of constructional and equipment standards in conjunction with strict operational controls.¹⁴

1.2 General requirements

1.2.1 The application of the provisions of this Code is subject to the following general requirements that:

- .1 the Code will be applied in its entirety;
- .2 the management of the company operating the craft exercises strict control over its operation and maintenance by a quality-management system¹⁵;
- .3 the management ensures that only persons qualified to operate the specific type of craft used on the intended route are employed;
- .4 the distances covered and the worst intended conditions in which high-speed craft operations are permitted will be restricted by the imposition of operational limits;
- .5 the craft will at all times be in reasonable proximity to a place of refuge, having due regard to the provisions of 1.3.4;

¹⁴ Refer to MSC/Circ.652 on Application of the 1966 LL Convention to high-speed craft.

¹⁵ Refer to the International Safety Management (ISM) Code adopted by the Organization by resolution A.741(18), as may be amended.

- .6 adequate communications facilities, weather forecasts and maintenance facilities are available within the area of craft operation;
- .7 in the intended area of operation suitable rescue facilities will be readily available;
- .8 areas of high fire risk, such as machinery spaces and special category spaces, are protected with fire-resistant materials and fire-extinguishing systems to ensure, as far as is practicable, containment and rapid extinguishing of fire;
- .9 efficient facilities are provided for the rapid and safe evacuation of all persons into survival craft;
- .10 all passengers and crew are provided with seats;
- .11 no enclosed sleeping berths for passengers are provided.

1.2.2¹⁶ On all craft, new installation of materials containing asbestos used for the structure, machinery, electrical installations and equipment of a craft to which this Code applies shall be prohibited except for:

- .1 vanes used in rotary vane compressors and rotary vane vacuum pumps;
- .2 watertight joints and linings used for the circulation of fluids when, at high temperature (in excess of 350°C) or pressure (in excess of 7×10^6 Pa), there is a risk of fire, corrosion or toxicity; and
- .3 supple and flexible thermal insulation assemblies used for temperatures above 1000°C.

1.3 Application

1.3.1 This Code applies to high speed craft as specified in 1.3.4 engaged in international voyages the keels of which are laid or which are at a similar stage of construction on or after 1 July 2002.

1.3.2 For the purpose of this Code, the term "a similar stage of construction" means the stage at which:

- .1 construction identifiable with a specific craft begins; and

¹⁶ Asbestanvändning är förbjudet i Sverige enligt Kommissionens förordning (EG) nr 552/2009 av den 22 juni 2009 om ändring av bilaga XVII till Europaparlamentets och rådets förordning (EG) nr 1907/2006 om registrering, utvärdering, godkännande och begränsning av kemikalier (REACH). Bestämmelsen ska därför inte tillämpas.

- .2 assembly of that craft has commenced comprising at least 50 tonnes or three per cent of the estimated mass of all material used in the structure, including superstructure and deckhouse, whichever is less.

1.3.3 For the purpose of this Code :

- .1 the expression "craft constructed" means craft the keels of which are laid or which are at a similar stage of construction; and
- .2 a cargo craft, whenever built, which is converted to a passenger craft shall be treated as a passenger craft constructed on the date on which such a conversion commences.

1.3.4 This Code applies to:

- .1 passenger craft which do not proceed in the course of their voyage more than four hours at 90% of maximum speed from a place of refuge; and
- .2 cargo craft of 500 gross tonnage and upwards which do not proceed in the course of their voyage more than 8 h at 90% of maximum speed from a place of refuge when fully laden.

1.3.5 This Code, unless expressly provided otherwise, does not apply to:

- .1 craft of war and troopcraft;
- .2 craft not propelled by mechanical means;
- .3 wooden craft of primitive build;
- .4 pleasure craft not engaged in trade; and
- .5 fishing craft.

1.3.6 This Code does not apply to craft solely navigating the Great Lakes of North America and the River St. Lawrence as far east as a straight line drawn from Cap des Rosiers to West Point, Anticosti Island and, on the north side of Anticosti Island, the 63rd meridian.

1.3.7 The application of this Code shall be verified by the Administration and be acceptable to the Governments of the States to which the craft will be operating.

1.4 Definitions

For the purpose of this Code, unless expressly provided otherwise, the terms used therein have the meanings defined in the following paragraphs. Additional definitions are given in the general parts of the various chapters.

1.4.1 "Administration" means the Government of the State whose flag the craft is entitled to fly.

1.4.2 "Air-cushion vehicle (ACV)" is a craft such that the whole or a significant part of its weight can be supported, whether at rest or in motion, by a continuously generated cushion of air dependent for its effectiveness on the proximity of the surface over which the craft operates.

1.4.3 "Anniversary date" means the day and the month of each year which will correspond to the date of expiry of the relevant certificate.

1.4.4 "Assembly station" is an area where passengers can be gathered in the event of an emergency, given instructions and prepared to abandon the craft, if necessary. The passenger spaces may serve as assembly stations if all passengers can be instructed there and prepared to abandon the craft.

1.4.5 "Auxiliary machinery spaces" are spaces containing internal combustion engines of power output up to and including 110 kW driving generators, sprinkler, drencher or fire pumps, bilge pumps, etc., oil filling stations, switchboards of aggregate capacity exceeding 800 kW, similar spaces and trunks to such spaces.

1.4.6 "Auxiliary machinery spaces having little or no fire risk" are spaces such as refrigerating, stabilizing, ventilation and air conditioning machinery, switchboards of aggregate capacity 800 kW or less, similar spaces and trunks to such spaces.

1.4.7 "Base port" is a specific port identified in the route operational manual and provided with:

- .1 appropriate facilities providing continuous radio communications with the craft at all times while in ports and at sea;
- .2 means for obtaining a reliable weather forecast for the corresponding region and its due transmission to all craft in operation;
- .3 for a category A craft, access to facilities provided with appropriate rescue and survival equipment; and
- .4 access to craft maintenance services with appropriate equipment.

1.4.8 "Base port State" means the State in which the base port is located.

1.4.9 "Breadth (B)" means breadth of the broadest part of the moulded watertight envelope of the rigid hull, excluding appendages, at or below the design waterline in the displacement mode with no lift or propulsion machinery active.

1.4.10 "Cargo craft" is any high-speed craft other than passenger craft, and which is capable of maintaining the main functions and safety systems of unaffected spaces, after damage in any one compartment on board.

1.4.11 "Cargo spaces" are all spaces other than special category spaces and ro-ro spaces used for cargo and trunks to such spaces. For the purposes of Chapter 7, part D, "cargo spaces" include ro-ro spaces, special category spaces and open deck spaces.

1.4.12 "Category A craft" is any high-speed passenger craft:

.1 operating on a route where it has been demonstrated to the satisfaction of the flag and port States that there is a high probability that in the event of an evacuation at any point of the route, all passengers and crew can be rescued safely within the least of:

- the time to prevent persons in survival craft from exposure causing hypothermia in the worst intended conditions,
- the time appropriate with respect to environmental conditions and geographical features of the route, or
- 4 hours; and

.2 carrying not more than 450 passengers.

1.4.13 "Category B craft" is any high-speed passenger craft other than a category A craft, with machinery and safety systems arranged such that, in the event of any essential machinery and safety systems in any one compartment being disabled, the craft retains the capability to navigate safely. The damage scenarios considered in chapter 2 should not be inferred in this respect.

1.4.14 "Company" means the company as defined in chapter IX of the Convention.

1.4.15 "Continuously manned control station" is a control station which is continuously manned by a responsible member of the crew while the craft is in normal service.

1.4.16 "Control stations" are those spaces in which the craft's radio or navigating equipment (main displays and controls for equipment specified in 13.2 to 13.7) or the emergency source of power and emergency switchboard are located, or where the fire recording or fire control

equipment is centralized, or where other functions essential to the safe operation of the craft such as propulsion control, public address, stabilization systems, etc., are located.

1.4.17 "Convention" means the International Convention for the Safety of Life at Sea, 1974, as amended.

1.4.18 "Crew accommodation" are those spaces allocated for the use of the crew, and include cabins, sick bays, offices, lavatories, lounges and similar spaces.

1.4.19 "Critical design conditions" means the limiting specified conditions, chosen for design purposes, which the craft shall keep in displacement mode. Such conditions shall be more severe than the "worst intended conditions" by a suitable margin to provide for adequate safety in the survival condition.

1.4.20 "Datum" means a watertight deck or equivalent structure of a non-watertight deck covered by a weathertight structure of adequate strength to maintain the weathertight integrity and fitted with weathertight closing appliances.

1.4.21 "Design waterline" means the waterline corresponding to the maximum operational weight of the craft with no lift or propulsion machinery active and is limited by the requirements of chapters 2 and 3.

1.4.22 "Displacement mode" means the regime, whether at rest or in motion, where the weight of the craft is fully or predominantly supported by hydrostatic forces.

1.4.23 "Failure Mode and Effect Analysis (FMEA)" is an examination, in accordance with annex 4, of the craft's system and equipment to determine whether any reasonably probable failure or improper operation can result in a hazardous or catastrophic effect.

1.4.24 "Fire Test Procedures Code (FTP Code)" means the International Code for Application of Fire Test Procedures, as defined in chapter II-2 of the Convention.

1.4.25 "Flap" means an element formed as integrated part of, or an extension of, a foil, used to adjust the hydrodynamic or aerodynamic lift of the foil.

1.4.26 "Flashpoint" means a flashpoint determined by a test using the closed-cup apparatus referenced in the International Maritime Dangerous Goods (IMDG) Code.

1.4.27 "Foil" means a profiled plate or three dimensional construction at which hydrodynamic lift is generated when the craft is under way.

1.4.28 "Fully submerged foil" means a foil having no lift components piercing the surface of the water in the foil-borne mode.

1.4.29 "Galley" are those enclosed spaces containing cooking facilities with exposed heating surfaces, or which have any cooking or food heating appliances each having a power of more than 5 kW.

1.4.30 "High-speed craft" is a craft capable of maximum speed, in metres per second (m/s), equal to or exceeding:

$$3.7 \nabla^{0.1667}$$

where:

∇ = volume of displacement corresponding to the design waterline (m³)

excluding craft the hull of which is supported completely clear above the water surface in non-displacement mode by aerodynamic forces generated by ground effect.

1.4.31 "Hydrofoil craft" is a craft the hull of which is supported completely clear above the water surface in non-displacement mode by hydrodynamic forces generated on foils.

1.4.32 "IMDG Code" means the International Maritime Dangerous Goods (IMDG) Code as defined in chapter VII of the Convention.

1.4.33 "Length (L)" means the overall length of the underwater watertight envelope of the rigid hull, excluding appendages, at or below the design waterline in the displacement mode with no lift or propulsion machinery active.

1.4.34 "Lightweight" is the displacement of the craft in tonnes without cargo, fuel, lubricating oil, ballast water, fresh water and feedwater in tanks, consumable stores, passengers and crew and their effects.

1.4.35 "Life-Saving Appliances Code (LSA Code)" means the International Life-Saving Appliance Code as defined in chapter III of the Convention.

1.4.36 "Machinery spaces" are spaces containing internal combustion engines either used for main propulsion or having an aggregate total power output of more than 110 kW, generators, oil fuel units, major electrical machinery and similar spaces and trunks to such spaces.

1.4.37 "Maximum operational weight" means the overall weight up to which operation in the intended mode is permitted by the Administration.

1.4.38 "Maximum speed" is the speed achieved at the maximum continuous propulsion power for which the craft is certified at maximum operational weight and in smooth water.

1.4.39 "Non-displacement mode" means the normal operational regime of a craft when non-hydrostatic forces substantially or predominantly support the weight of the craft.

1.4.40 "Oil fuel unit" includes any equipment for the preparation of oil fuel and delivery of oil fuel, heated or not, to boilers and engines (including gas turbines) at a pressure of more than 0,18 N/mm².

1.4.41 "Open ro-ro spaces" are those ro-ro spaces:

- .1 to which any passengers carried have access; and
- .2 either:
 - .2.1 are open at both ends; or
 - .2.2 have an opening at one end and are provided with permanent openings distributed in the side plating or deckhead or from above, having a total area of at least 10% of the total area of the space sides.

1.4.42 "Operating limitations" means the craft limitations in respect of handling, controllability and performance and the craft operational procedures within which the craft is to operate.

1.4.43 "Operating compartment" means the enclosed area from which the navigation and control of the craft is exercised.

1.4.44 "Operating station" means a confined area of the operating compartment equipped with necessary means for navigation, manoeuvring and communication, and from where the functions of navigating, manoeuvring, communication, commanding, conning and lookout are carried out.

1.4.45 "Organization" means the International Maritime Organization.

1.4.46 "Passenger" is every person other than:

- .1 the master and members of the crew or other persons employed or engaged in any capacity on board a craft on the business of that craft; and
- .2 a child under one year of age.

1.4.47 "Passenger craft" is a craft which carries more than twelve passengers.

1.4.48 "Place of refuge" is any naturally or artificially sheltered area which may be used as a shelter by a craft under conditions likely to endanger its safety.

1.4.49 "Public spaces" are those spaces allocated for the passengers and include bars, refreshment kiosks, smoke rooms, main seating areas, lounges, dining rooms, recreation rooms, lobbies, lavatories and similar spaces, and may include sales shops.

1.4.50 "Refreshment kiosks" are those spaces which are not enclosed, serving refreshments and containing food warming equipment having a total power of 5 kW or less and with an exposed heating surface temperature not above 150°C.

1.4.51 "Ro-ro craft" is a craft fitted with one or more ro-ro spaces.

1.4.52 "Ro-ro spaces" are spaces not normally subdivided in any way and normally extending to either a substantial length or the entire length of the craft in which motor vehicles with fuel in their tanks for their own propulsion and/or goods (packaged or in bulk, in or on rail or road cars, vehicles (including road or rail tankers), trailers, containers, pallets, demountable tanks or in or on similar stowage units or other receptacles) can be loaded and unloaded, normally in a horizontal direction.

1.4.53 "Service spaces" are those enclosed spaces used for pantries containing food warming equipment but no cooking facilities with exposed heating surfaces, lockers, sales shops, store-rooms and enclosed baggage rooms. Such spaces containing no cooking appliances may contain:

- .1 coffee automats, toasters, dish washers, microwave ovens, water boilers and similar appliances, each of them with a maximum power of 5 kW; and
- .2 electrically heated cooking plates and hot plates for keeping food warm, each of them with a maximum power of 2 kW and a surface temperature not above 150°C.

1.4.54 "Significant wave height" is the average crest-to-trough height of the highest one third of the zero-upcrossing waves in a specified period.

1.4.55 "Special category spaces" are those enclosed ro-ro spaces to which passengers have access. Special category spaces may be accommodated on more than one deck provided that the total overall clear height for vehicles does not exceed 10 m.

1.4.56 "Surface-effect ship" (SES) is an air-cushion vehicle whose cushion is totally or partially retained by permanently immersed hard structures.

1.4.57 "Transitional mode" means the regime between displacement and non-displacement modes.

1.4.58 "Watertight" in relation to a structure means capable of preventing the passage of water through the structure in any direction under the head of water likely to occur in the intact or damaged condition.

1.4.59 "Weather deck" is a deck which is completely exposed to the weather from above and from at least two sides.

1.4.60 "Weathertight" means that water will not penetrate into the craft in any wind and wave conditions up to those specified as critical design conditions.

1.4.61 "Worst intended conditions" means the specified environmental conditions within which the intentional operation of the craft is provided for in the certification of the craft. This shall take into account parameters such as the worst conditions of wind force allowable, significant wave height (including unfavourable combinations of length and direction of waves), minimum air temperature, visibility and depth of water for safe operation and such other parameters as the Administration may require in considering the type of craft in the area of operation.

1.5 Surveys

1.5.1 Each craft shall be subject to the surveys specified below:

- .1 an initial survey before the craft is put in service or before the Certificate is issued for the first time;
- .2 a renewal survey at intervals specified by the Administration but not exceeding 5 years except where 1.8.5 or 1.8.10 is applicable;
- .3 a periodical survey within three months before or after each anniversary date of the Certificate; and
- .4 an additional survey as the occasion arises.

1.5.2 The surveys referred to in 1.5.1 shall be carried out as follows:

- .1 the initial survey shall include:
 - .1.1 an appraisal of the assumptions made and limitations proposed in relation to loadings, environment, speed and manoeuvrability;
 - .1.2 an appraisal of the data supporting the safety of the design, obtained, as appropriate, from calculations, tests and trials;

- .1.3 a failure mode and effect analysis as required by this Code;
 - .1.4 an investigation into the adequacy of the various manuals to be supplied with the craft; and
 - .1.5 a complete inspection of the structure, safety equipment, radio installations and other equipment, fittings, arrangements and materials to ensure that they comply with the requirements of the Code, are in satisfactory condition and are fit for the service for which the craft is intended;
- .2 the renewal and periodical surveys shall include a complete inspection of the structure, including the outside of the craft's bottom and related items, safety equipment, radio installations and other equipment as referred to in 1.5.2.1 to ensure that they comply with the requirements of the Code, are in satisfactory condition and are fit for the service for which the craft is intended. The inspection of the craft's bottom shall be conducted with the craft out of the water under suitable conditions for close-up examination of any damaged or problem areas; and
- .3 an additional survey, either general or partial according to the circumstances, shall be made after a repair resulting from investigations prescribed in 1.7.3, or wherever any important repairs or renewals are made. The survey shall be such as to ensure that the necessary repairs or renewals have been effectively made, that the material and workmanship of such repairs or renewals are in all respects satisfactory, and that the craft complies in all respects with the requirements of the Code.

1.5.3 The periodical surveys referred to in 1.5.1.3 shall be endorsed on the High-Speed Craft Safety Certificate.

1.5.4 The inspection and survey of the craft, so far as regards the enforcement of the provisions of the Code, shall be carried out by officers of the Administration. The Administration may, however, entrust the inspections and surveys either to surveyors nominated for the purpose or to organizations recognized by it.

1.5.5 An Administration nominating surveyors or recognizing organizations to conduct inspections and surveys as set forth in 1.5.4 shall, as a minimum, empower any nominated surveyor or recognized organization to:

- .1 require repairs to a craft; and
- .2 carry out inspections and surveys if requested by the appropriate authorities of a port State.

The Administration shall notify the Organization of the specific responsibilities and conditions of the authority delegated to nominated surveyors or recognized organizations.

1.5.6 When a nominated surveyor or recognized organization determines that the condition of the craft or its equipment does not correspond substantially with the particulars of the Certificate or is such that the craft is not fit to operate without danger to the craft or persons on board, the surveyor or organization shall immediately ensure that corrective action is taken and shall, in due course, notify the Administration. If such corrective action is not taken, the Certificate shall be withdrawn and the Administration shall be notified immediately; and, if the craft is in an area under the jurisdiction of another Government, the appropriate authorities of the port State shall be notified immediately. When an officer of the Administration, a nominated surveyor or a recognized organization has notified the appropriate authorities of the port State, the Government of the port State concerned shall give such officer, surveyor or organization any necessary assistance to carry out their obligations under this section. When applicable, the Government of the port State concerned shall ensure that the craft shall not continue to operate until it can do so without danger to the craft or the persons on board.

1.5.7 In every case, the Administration shall fully guarantee the completeness and efficiency of the inspection and survey, and shall undertake to ensure the necessary arrangements to satisfy this obligation.

1.6 Approvals

The owner of a craft shall accept the obligation to supply sufficient information to enable the Administration to fully assess the features of the design. It is strongly recommended that the Company and the Administration and, where appropriate, the port State or States shall commence discussions at the earliest possible stage so that the Administration may fully evaluate the design in determining what additional or alternative requirements shall be applied to the craft, to achieve the required level of safety.

1.7 Maintenance of conditions after survey

1.7.1 The condition of the craft and its equipment shall be maintained to conform with the provisions of this Code to ensure that the craft in all respects will remain fit to operate without danger to the craft or the persons on board.

1.7.2 After any survey of the craft under section 1.5 has been completed, no change shall be made to structure, equipment, fittings, arrangements and materials covered by the survey, without the sanction of the Administration.

1.7.3 Whenever an accident occurs to a craft or a defect is discovered, either of which affects the safety of the craft or the efficiency or completeness of structure, equipment, fittings, arrangements and materials, the person in charge or owner of the craft shall report at the earliest opportunity to the Administration, the nominated surveyor or recognized organization responsible, who shall cause investigations to be initiated to determine whether a survey, as required by section 1.5, is necessary. If the craft is in an area under the jurisdiction of another Government, the person in charge or the owner shall also report immediately to the appropriate authorities of the port State and the nominated surveyor or recognized organization shall ascertain that such a report has been made.

1.8 High-Speed Craft Safety Certificate

1.8.1 A Certificate called a High-Speed Craft Safety Certificate is issued after completion of an initial or renewal survey to a craft which complies with the requirements of the Code. The Certificate shall be issued or endorsed either by the Administration or by any person or organization recognized by it. In every case, that Administration assumes full responsibility for the Certificate. On all craft, all certificates issued under this chapter, or certified copies thereof, shall be carried on the craft. Except where the flag State is a Party to the 1988 SOLAS Protocol, a copy of each of these certificates shall be posted up in a prominent and accessible place in the craft.

1.8.2 A Contracting Government to the Convention may, at the request of the Administration, cause a craft to be surveyed and, if satisfied that the requirements of the Code are complied with, shall issue or authorise the issue of a Certificate to the craft and, where appropriate, endorse or authorise the endorsement of a Certificate on the craft in accordance with the Code. Any Certificate so issued shall contain a statement to the effect that it has been issued at the request of the Government of the State the flag of which the craft is entitled to fly, and it shall have the same force and receive the same recognition as a Certificate issued under 1.8.1.

1.8.3 The Certificate shall be that of the model given in the annex 1 to the Code. If the language used is not English, French or Spanish, the text shall include a translation into one of these languages.

1.8.4 The High-Speed Craft Safety Certificate shall be issued for a period specified by the Administration which shall not exceed 5 years.

1.8.5 Notwithstanding the requirements of 1.8.4, when the renewal survey is completed within three months before the expiry date of the existing Certificate, the new Certificate shall be valid from the date of

completion of the renewal survey to a date not exceeding 5 years from the date of expiry of the existing Certificate.

1.8.6 When the renewal survey is completed after the expiry date of the existing Certificate, the new Certificate shall be valid from the date of completion of the renewal survey to a date not exceeding 5 years from the date of expiry of the existing Certificate.

1.8.7 When the renewal survey is completed more than 3 months before the expiry date of the existing Certificate, the new Certificate shall be valid from the date of completion of the renewal survey to a date not exceeding 5 years from the date of completion of the renewal survey.

1.8.8 If a Certificate is issued for a period of less than 5 years, the Administration may extend the validity of the Certificate beyond the expiry date to the maximum period specified in 1.8.4, provided that the surveys when a Certificate is issued for a period of 5 years are carried out.

1.8.9 If a renewal survey has been completed and a new Certificate cannot be issued or placed on board the craft before the expiry date of the existing Certificate, the person or organization authorized by the Administration may endorse the existing Certificate and such a Certificate shall be accepted as valid for a further period which shall not exceed 5 months from the expiry date.

1.8.10 If a craft, at the time when a Certificate expires, is not in the place in which it is to be surveyed, the Administration may extend the period of validity of the Certificate but this extension shall be granted only for the purpose of allowing the craft to proceed to the place in which it is to be surveyed, and then only in cases where it appears proper and reasonable to do so. No Certificate shall be extended for a period longer than one month, and a craft to which an extension is granted shall not, on its arrival in the place in which it is to be surveyed, be entitled by virtue of such extension to leave that place without having a new Certificate. When the renewal survey is completed, the new Certificate shall be valid to a date not exceeding 5 years from the date of expiry of the existing Certificate before the extension was granted.

1.8.11 In special circumstances, as determined by the Administration, a new Certificate need not be dated from the date of expiry of the existing Certificate as required by 1.8.6 or 1.8.10. In these circumstances, the new Certificate shall be valid to a date not exceeding 5 years from the date of completion of the renewal survey.

1.8.12 If a periodical survey is completed before the period specified in section 1.5 then:

- .1 the anniversary date shown on the relevant Certificate shall be amended by endorsement to a date which shall not be more than 3 months later than the date on which the survey was completed;

- .2 the subsequent periodical survey required by section 1.5 shall be completed at the intervals prescribed by 1.5 using the new anniversary date; and
- .3 the expiry date may remain unchanged provided one or more periodical surveys are carried out so that the maximum intervals between the surveys prescribed by 1.5.1.3 are not exceeded;

1.8.13 A Certificate issued under 1.8.1 or 1.8.2 shall cease to be valid in any of the following cases:

- .1 if the relevant surveys are not completed with the periods specified in 1.5.1;
- .2 if the Certificate is not endorsed in accordance with 1.5.3;
- .3 upon transfer of the craft to the flag of another State. A new Certificate shall only be issued when the Government issuing the new Certificate is fully satisfied that the craft is in compliance with the requirements of 1.7.1 and 1.7.2. In the case of a transfer between Governments that are Contracting Governments to the Convention if requested within 3 months after the transfer has taken place, the Government of the State whose flag the craft was formerly entitled to fly shall, as soon as possible, transmit to the Administration a copy of the Certificate carried by the craft before the transfer and, if available, copies of the relevant survey reports.

1.8.14 The privileges of the Code may not be claimed in favour of any craft unless it holds a valid Certificate.

1.9 Permit to Operate High-Speed Craft

1.9.1 The craft shall not operate commercially unless a Permit to Operate High-Speed Craft is issued and valid in addition to the High-Speed Craft Safety Certificate.

1.9.1.1 On all craft, transit voyages may be undertaken without a valid Permit to Operate High-Speed Craft provided the craft is not operating commercially with passengers or cargo onboard. For the purpose of this provision, these transit voyages include delivery voyages, i.e., builder's port to base port, and voyages for repositioning purposes, i.e. change of base port and/or route. Such transit voyages in excess of the limits set out in this Code may be undertaken provided that:

- .1 the craft has a valid High-Speed Craft Safety Certificate or similar before the start of such a voyage;
- .2 the operator has developed a safety plan for the voyage including any temporary accommodation and all relevant matters listed in 18.1.3 to ensure that the craft is capable of safely completing the transit voyage;
- .3 the master of the craft is provided with the materials and information necessary to operate the craft safely during the transit voyage; and
- .4 the Administration is satisfied that arrangements have been made for the safe conduct of the voyage.

1.9.2 The Permit to Operate High-Speed Craft shall be issued by the Administration to certify compliance with 1.2.2 to 1.2.7 and stipulate conditions of the operation of the craft and drawn up on the basis of the information contained in the route operational manual specified in chapter 18 of this Code.

1.9.3 Before issuing the Permit to Operate, the Administration shall consult with each port State to obtain details of any operational conditions associated with operation of the craft in that State. Any such conditions imposed shall be shown by the Administration on the Permit to Operate and included in the route operational manual.

1.9.4 A port State may inspect the craft and audit its documentation for the sole purpose of verifying its compliance with the matters certified by and conditions associated with the Permit to Operate. Where deficiencies are shown by such an audit, the Permit to Operate ceases to be valid until such deficiencies are corrected or otherwise resolved.

1.9.5 The provisions of 1.8 shall apply to the issue and the period of validity of the Permit to Operate High-Speed Craft.

1.9.6 The Permit to Operate High-Speed Craft shall be that of the model given in annex 2 to this Code. If the language used is not English, French or Spanish, the text shall include a translation into one of these languages.

1.9.7 In determining the worst intended conditions and the operational limitations on all craft for insertion in the Permit to Operate, the Administration shall give consideration to all the parameters listed in annex 12. The limitations assigned shall be those that enable compliance with all of these factors.

1.10 Control

1.10.1 The provisions of regulation I/19 of the Convention shall be applied to include the Permit to Operate High-Speed Craft in addition to the Certificate issued under 1.8.

1.11 Equivalents

1.11.1 Where this Code requires that a particular fitting, material, appliance or apparatus, or type thereof, shall be fitted or carried in a craft, or that any particular provision shall be made, the Administration may allow any other fitting, material, appliance or apparatus, or type thereof, to be fitted or carried, or any other provision to be made in the craft, if it is satisfied by trial thereof or otherwise that such fitting, material, appliance or apparatus, or type thereof, or provision, is at least as effective as that required by this Code.

1.11.2 Where compliance with any of the requirements of this Code would be impractical for the particular designs of the craft, the Administration may substitute those with alternative requirements provided that equivalent safety is achieved. The Administration which allows any such substitution shall communicate to the Organization Particulars of these substitutions and the reasons therefor, which the Organization shall circulate to its Member Governments for their information.

1.12 Information to be made available

1.12.1 The Administration shall ensure that the management of the company operating the craft has provided the craft with adequate information and guidance in the form of manuals to enable the craft to be operated and maintained safely. These manuals shall include a route operational manual, craft operating manual, maintenance manual and servicing schedule. Such information shall be updated as necessary.

1.12.2 The manuals shall contain at least the information specified in chapter 18, and shall be in a language understood by the crew. Where this language is not English, a translation into English shall be provided of at least the route operational manual and the craft operating manual.

1.13 Further developments

1.13.1 It is recognized that there is much ongoing research and development in the design of high-speed craft and that new types may emerge which have different geometry to that envisaged during the formulation of this Code. It is important that this Code does not restrict this progress and the development of new designs.

1.13.2 A design may be produced which cannot comply with the provisions of this Code. In such a case the Administration shall determine the extent to which the provisions of the Code are applicable to the design and, if necessary, develop additional or alternative requirements to provide an equivalent level of safety for the craft.

1.13.3 The foregoing shall be considered by the Administration when assessing the granting of equivalents under the Code.

1.14 Circulation of safety information

1.14.1 In the event that an Administration has cause to investigate an accident involving a craft to which this Code applies, that Administration shall provide a copy of the official report to the Organization, which will invite Member States to note the existence of the report and to obtain a copy.

1.14.2 In the event that operational experience reveals structural or equipment failures affecting the safety of a design, craft owners shall inform the Administration.

1.15 Review of the Code

1.15.1 The Code shall be reviewed by the Organization at intervals preferably not exceeding six years to consider revision of existing requirements to take account of new developments in design and technology.

1.15.2 Where a new development in design and technology has been found acceptable to an Administration, that Administration may submit particulars of such development to the Organization for consideration for incorporation into the Code during periodical review.

CHAPTER 2

Buoyancy, stability and subdivision

PART A - GENERAL

2.1 General

2.1.1 A craft shall be provided with:

- .1 stability characteristics and stabilization systems adequate for safety when the craft is operated in the non-displacement mode and during the transitional mode;
- .2 buoyancy and stability characteristics adequate for safety where the craft is operated in the displacement mode, both in the intact condition and the damaged condition; and
- .3 stability characteristics in the non-displacement and transitional modes adequate to transfer the craft safely to displacement mode in case of any system malfunction.

2.1.2 Account shall be taken of the effect of icing in the stability calculations. An example of established practice for ice accretion allowances is given in annex 5 for the guidance of the Administration.

2.1.3 For the purpose of this and other chapters, unless expressly defined otherwise, the following definitions apply:

- .1 *Downflooding point* means any opening, irrespective of size, that would permit passage of water through a water/weathertight structure (e.g., opening windows), but excludes any opening kept closed to an appropriate standard of water/weathertightness at all times other than when required for access or for operation of portable submersible bilge pumps in an emergency (e.g., non-opening windows of similar strength and weathertight integrity to the structure in which they are installed).
- .2 *Elsewhere* when applied to sill and coaming heights in 2.2.7 and 2.2.8 is taken as applying to all weathertight and watertight closures located on or below the datum."
- .3 "Fully submerged foil" means a foil having no lift components piercing the surface of the water in the foil-borne mode.
- .4 "Monohull craft" means any craft which is not a multihull craft.

- .5 "Multihull craft" means a craft which in any normally achievable operating trim or heel angle, has a rigid hull structure which penetrates the surface of the sea over more than one discrete area.
- .6 "Permeability" of a space means the percentage of the volume of that space which can be occupied by water.
- .7 "Skirt" means a downwardly extending, flexible structure used to contain or divide an air cushion.

2.1.4 Other means of demonstrating compliance with the requirements of any part of this Chapter may be accepted, provided that the method chosen can be shown to provide an equivalent level of safety. Such methods may include:

- .1 mathematical simulation of dynamic behaviour;
- .2 scale model testing; and
- .3 full-scale trials.

2.1.5 The adequacy of mathematical simulations must first be demonstrated by correlation with full-scale or model tests for the appropriate type of craft. It may be appropriate to use mathematical simulations to help to identify the more critical scenarios for subsequent physical testing.*

2.1.6 Model or full-scale tests and/or calculations (as appropriate) shall also include consideration of the following known stability hazards to which high-speed craft are known to be liable, according to craft type:

- .1 directional instability, which is often coupled to roll and pitch instabilities;
- .2 broaching and bow diving in following seas at speeds near to wave speed, applicable to most types;
- .3 bow diving of planing monohulls and catamarans due to dynamic loss of longitudinal stability in relatively calm seas;
- .4 reduction in transverse stability with increasing speed of monohulls;

* Some mathematical simulation methods are not well suited to accurate modelling of extreme events. For safety level 3 or 4, it may be appropriate to use model testing as a precursor to, or instead of, full-scale testing.

- .5 porpoising of planing monohulls, being coupled pitch and heave oscillations, which can become violent;
- .6 chine tripping, being a phenomenon of planing monohulls occurring when the immersion of a chine generates a strong capsizing moment;
- .7 plough-in of air-cushion vehicles, either longitudinal or transverse, as a result of bow or side skirt tuck-under or sudden collapse of skirt geometry, which, in extreme cases, can result in capsize;
- .8 pitch instability of SWATH (small waterplane area twin hull) craft due to the hydrodynamic moment developed as a result of the water flow over the submerged lower hulls;
- .9 reduction in effective metacentric height (roll stiffness) of surface effect ship (SES) in high speed turns compared to that on a straight course, which can result in sudden increases in heel angle and/or coupled roll and pitch oscillations; and
- .10 resonant rolling of SES in beam seas, which, in extreme cases, can result in capsize.

2.1.7 Suitable calculations shall be carried out and/or tests conducted to demonstrate that, when operating within approved operational limitations, the craft will, after a disturbance causing roll, pitch, heave or heel due to turning or any combination thereof, return to the original attitude. Where calculations are employed, it shall first be shown that they correctly represent dynamic behaviour within the operational limitations of the craft.

2.2 Intact buoyancy and watertight and weathertight integrity

2.2.1 Buoyant spaces

2.2.1.1 All craft shall have a sufficient reserve of buoyancy at the design waterline to meet the intact and damage stability requirements of this chapter. The Administration may require a larger reserve of buoyancy to permit the craft to operate in any of its intended modes. This reserve of buoyancy shall be calculated by including only those compartments that are:

- .1 watertight and situated below the datum, or
- .2 watertight or weathertight and situated above the datum.

In considering the stability after damage, flooding shall be assumed to occur until limited by watertight boundaries in the equilibrium condition,

and weathertight boundaries in intermediate stages of flooding and within the range of positive righting lever required to satisfy the residual stability requirements. Where a buoyant space may be subjected to increased fluid pressure in the equilibrium position after damage, the boundaries and associated openings and penetrations of that space shall be designed and constructed to prevent the passage of fluid under that pressure.

Craft built in conformity with the requirements of organizations recognised by the Administration, in accordance with regulation XI/1 of the Convention may be considered to possess adequate strength and integrity.

2.2.1.2 Arrangements shall be provided for checking the watertight or weathertight integrity of those compartments taken into account in 2.2.1.1, and the details incorporated in the Craft Operating Manual required by 18.2.1.

2.2.2 Openings in watertight divisions

2.2.2.1 The number of openings in watertight bulkheads shall be reduced to the minimum compatible with the design and proper working of the craft, and all such doors shall be closed prior to departure of the craft from the berth.

2.2.2.2 Doors in watertight bulkheads may be hinged or sliding. They shall be shown by suitable testing to be capable of maintaining the watertight integrity of the bulkhead. Such testing shall be carried out for both sides of the door and shall apply a pressure head 10% greater than that determined from the minimum permissible height of a downflooding opening. Testing may be carried out either before or after the door is fitted into the craft but, where shore testing is adopted, satisfactory installation in the craft shall be verified by inspection and hose testing.

2.2.2.3 Type approval may be accepted in lieu of testing individual doors, provided the approval process includes pressure testing to a head equal to, or greater, than the required head (refer to 2.2.2.2).

2.2.2.4 All watertight doors shall be capable of being operated when the craft is inclined up to 15°, and shall be fitted with means of indication in the operating compartment showing whether they are open or closed. All such doors shall be capable of being opened and closed locally from each side of the bulkhead.

2.2.2.5 Watertight doors shall remain closed when the craft is at sea, except that they may be opened for access. A notice shall be attached to each door to the effect that it is not to be left open.

2.2.2.6 Watertight doors shall be capable of being closed by remote control from the operating compartment in not less than 20 s and not more than 40 s, and shall be provided with an audible alarm, distinct from other alarms in the area, which will sound for at least 5 s but no more than 10 s before the doors begin to move whenever the door is closed remotely by

power, and continue sounding until the door is completely closed. The power, control and indicators shall be operable in the event of main power failure, as required by regulation II-1/15.7.3 of the Convention. In passenger areas and areas where the ambient noise exceeds 85 dB(A) the audible alarm shall be supplemented by an intermittent visual signal at the door. If the Administration is satisfied that such doors are essential for the safe work of the craft, hinged watertight doors having only local control may be permitted for areas to which crew only have access, provided they are fitted with remote indicators as required by 2.2.2.4.

2.2.2.7 Where pipes, scuppers, electric cables, etc. are carried through watertight divisions, the arrangements for creating a watertight penetration shall be of a type which has been prototype tested under hydrostatic pressure equal to or greater than that required to be withstood for the actual location in the craft in which they are to be installed. The test pressure shall be maintained for at least 30 min and there must be no leakage through the penetration arrangement during this period. The test pressure head shall be 10% greater than that determined from the minimum permissible height of a downflooding opening. Watertight bulkhead penetrations which are effected by continuous welding do not require prototype testing. Valves on scuppers from weathertight compartments, included in the stability calculations, shall have arrangements for remote closing from the operating station.

2.2.2.8 Where a ventilation trunk forms part of a watertight boundary, the trunk shall be capable of withstanding the water pressure that may be present taking into account the maximum inclination angle allowable during all stages of flooding.

2.2.3 Inner bow doors

2.2.3.1 Where ro-ro craft are fitted with bow loading openings, an inner bow door shall be fitted abaft such openings, to restrict the extent of flooding in the event of failure of the outer closure. This inner bow door, where fitted, shall be:

- .1 weathertight to the deck above, which deck shall itself be weathertight forward to the bow loading opening;
- .2 so arranged as to preclude the possibility of a bow loading door causing damage to it in the case of damage to, or detachment of, the bow loading door;
- .3 forward of all positions on the vehicle deck in which vehicles are intended to be carried; and
- .4 part of a boundary designed to prevent flooding into the remainder of the craft.

2.2.3.2 A craft may be exempted from the requirement for such an inner bow door where one of the following applies:

- .1 the vehicle loading deck at the inner bow door position is above the design waterline by a height more than the significant wave height corresponding to the worst intended conditions;
- .2 it can be demonstrated using model tests or mathematical simulations that when the craft is proceeding at a range of speeds up to the maximum attainable speed in the loaded condition at all headings in long crested seas of the greatest significant wave height corresponding to the worst intended conditions, either:
 - .1 the bow loading door is not reached by waves;
or
 - .2 having been tested with the bow loading door open to determine the maximum steady state volume of water which accumulates, it can be shown by static analysis that, with the same volume of water on the vehicle deck(s) the residual stability requirements of 2.6.11 and 2.13 or 2.15 are satisfied. If the model tests or mathematical simulations are unable to show that the volume of water accumulated reaches a steady state, the craft shall be considered not to have satisfied the conditions of this exemption.

Where mathematical simulations are employed they shall already have been verified against full-scale or model testing;

- .3 bow loading openings lead to open ro-ro spaces provided with guard-rails or having freeing ports complying with 2.2.3.2.4;
- .4 the deck of the lowest ro-ro space above the design waterline is fitted on each side of the deck with freeing ports evenly distributed along the sides of the compartment. These shall either be proven to be acceptable using tests according to 2.2.3.2.2 above or comply with the following:

.1 $A \geq 0.3 l$

where :

A = the total area of freeing ports on each side of the deck in m²; and

l = the length of the compartment in m;

- .2 the craft shall maintain a residual freeboard to the deck of the ro-ro space of at least 1 m in the worst condition;
- .3 such freeing ports shall be located within the height of 0.6 m above the deck of the ro-ro space, and the lower edge of the ports shall be within 0.02 m above the deck of the ro-ro space; and
- .4 such freeing ports shall be fitted with closing devices or flaps to prevent water entering the deck of the ro-ro space whilst allowing water which may accumulate on the deck of the ro-ro space to drain.

2.2.4 Other provisions for ro-ro craft

2.2.4.1 All accesses in the ro-ro space that lead to spaces below the deck shall have a lowest point which is not less than the height required from the tests conducted according to 2.2.3.2.2 or 3 m above the design waterline.

2.2.4.2 Where vehicle ramps are installed to give access to spaces below the deck of the ro-ro space, their openings shall be capable of being closed weathertight to prevent ingress of water below.

2.2.4.3 Accesses in the ro-ro space that lead to spaces below the ro-ro deck and having a lowest point which is less than the height required from the tests conducted according to 2.2.3.2.2 or 3 m above the design waterline may be permitted provided they are watertight and are closed before the craft leaves the berth on any voyage and remain closed until the craft is at its next berth.

2.2.4.4 The accesses referred to in 2.2.4.2 and 2.2.4.3 above shall be fitted with alarm indicators in the operating compartment.

2.2.4.5 Special category spaces and ro-ro spaces shall be patrolled or monitored by effective means, such as television surveillance, so that any movement of vehicles in adverse weather conditions and unauthorised access by passengers thereto can be detected whilst the craft is underway (refer to 7.8.3.1).

2.2.5 Indicators and surveillance

2.2.5.1 Indicators

Indicators shall be provided in the operating compartment for all shell doors, loading doors and other closing appliances which, if left open or not properly secured, could lead to major flooding in the intact and damage conditions. The indicator system shall be designed on the fail-safe principle and shall show by visual alarms if the door is not fully closed or if any of the securing arrangements are not in place and fully locked, and by audible alarms if such door or closing appliance becomes open or the securing arrangements become unsecured. The indicator panel in the operating compartment shall be equipped with a mode selection function 'harbour/sea voyage' so arranged that an audible alarm is given in the operating compartment if the craft leaves harbour with the bow doors, inner doors, stern ramp or any other side shell doors not closed or any closing device not in the correct position. The power supply for the indicator systems shall be independent of the power supply for operating and securing the doors.

2.2.5.2 Television surveillance

Television surveillance and a water leakage detection system shall be arranged to provide an indication to the operating compartment and to the engine control station of any leakage through inner and outer bow doors, stern doors or any other shell doors which could lead to major flooding.

2.2.6 Integrity of superstructure

2.2.6.1 Where entry of water into structures above the datum would significantly influence the stability and buoyancy of the craft, such structures shall be:

- .1 of adequate strength to maintain the weathertight integrity and fitted with weathertight closing appliances; or
- .2 provided with adequate drainage arrangements; or
- .3 an equivalent combination of both measures.

2.2.6.2 Weathertight superstructures and deckhouses located above the datum shall in the outside boundaries have means of closing openings with sufficient strength such as to maintain weathertight integrity in all damage conditions where the space in question is not damaged. Furthermore, the

means of closing shall be such as to maintain weathertight integrity in all operational conditions.

2.2.7 Doors, windows, etc., in boundaries of weathertight spaces.

2.2.7.1 Doors, windows, etc., and any associated frames and mullions in weathertight superstructures and deckhouses shall be weathertight and shall not leak or fail at a uniformly applied pressure less than that at which adjacent structure would experience permanent set or fail. Conformity with the requirements of organizations recognized by the Administration in accordance with regulation XI/1 of the Convention may be considered to possess adequate strength.

2.2.7.2 For doors in weathertight superstructures, hose tests shall be carried out with a water pressure from the outside in accordance with specifications at least equivalent to those acceptable to the Organization¹⁷.

2.2.7.3 The height above the deck of sills to doorways leading to exposed decks shall be as high above the deck as is reasonable and practicable, particularly those located in exposed positions. Such sill heights shall in general not be less than 100 mm for doors to weathertight spaces on decks above the datum, and 250 mm elsewhere. For craft of 30 m in length and under, sill heights may be reduced to the maximum which is consistent with the safe working of the craft.

2.2.7.4 Windows shall not be permitted in the boundaries of special category spaces or ro-ro spaces or below the datum. If required by restrictions in the Permit to Operate, forward facing windows, or windows which may be submerged at any stage of flooding shall be fitted with hinged or sliding storm shutters ready for immediate use.

2.2.7.5 Side scuttles to spaces below the datum shall be fitted with efficient hinged deadlights arranged inside so that they can be effectively closed and secured watertight.

2.2.7.6 No side scuttle shall be fitted in a position so that its sill is below a line drawn parallel to and one metre above the design waterline.

2.2.8 Hatchways and other openings

2.2.8.1 Hatchways closed by weathertight covers

The construction and the means for securing the weathertightness of cargo and other hatchways shall comply with the following:

¹⁷ Refer to ISO 6042 - Ships and Marine Technology - Weathertight single-leaf steel doors, or a similar standard.

- .1 coaming heights shall in general not be less than 100 mm for hatches to weathertight spaces on decks above the datum, and 250 mm elsewhere. For craft of 30 m in length and under, coaming heights may be reduced to the maximum which is consistent with the safe working of the craft;
- .2 the height of these coamings may be reduced, or the coamings omitted entirely, on condition that the Administration is satisfied that the safety of the ship is not thereby impaired in any sea conditions up to the worst intended conditions. Where coamings are provided, they shall be of substantial construction; and
- .3 the arrangements for securing and maintaining weathertightness shall ensure that the tightness can be maintained in any sea conditions up to the worst intended conditions.

2.2.8.2 Machinery space openings

2.2.8.2.1 Machinery space openings shall be properly framed and efficiently enclosed by casings of ample strength and, where the casings are not protected by other structures, their strength shall be specially considered. Access openings in such casings shall be fitted with weathertight doors.

2.2.8.2.2 Heights of sills and coaming shall, in general, not be less than 100 mm for openings to weathertight spaces on decks above the datum, and 380 mm elsewhere. For craft of 30 m in length and under, these heights may be reduced to the maximum which is consistent with the safe working of the craft.

2.2.8.2.3 Machinery space ventilator openings shall comply with the requirements of 2.2.8.4.2.

2.2.8.3 Miscellaneous openings in exposed decks

2.2.8.3.1 Manholes and flush scuttles on the datum or within superstructures other than enclosed superstructures shall be closed by substantial covers capable of being made watertight. Unless secured by closely spaced bolts, the covers shall be permanently attached.

2.2.8.3.2 Service hatches to machinery, etc. may be arranged as flush hatches provided that the covers are secured by closely spaced bolts, are kept closed at sea, and are equipped with arrangements for portable guardrails.

2.2.8.3.3 Openings in exposed decks leading to spaces below the datum or enclosed superstructures other than hatchways, machinery space openings, manholes and flush scuttles shall be protected by an enclosed superstructure,

or by a deckhouse or companionway of equivalent strength and weathertightness.

2.2.8.3.4 The height above the deck of sills to the doorways in companionways shall, in general, not be less than 100 mm for doors to weathertight spaces on decks above the datum, and 250 mm elsewhere. For craft of 30 m in length and under sill heights may be reduced to the maximum which is consistent with the safe working of the craft.

2.2.8.4 Ventilators

2.2.8.4.1 Ventilators to spaces below the datum or decks of enclosed superstructures shall have substantially constructed coamings efficiently connected to the deck. Coaming heights shall in general not be less than 100 mm for ventilators to weathertight spaces on decks above the datum, and 380 mm elsewhere. For craft of 30 m in length and under, coaming heights may be reduced to the maximum which is consistent with the safe working of the craft.

2.2.8.4.2 Ventilators the coamings of which extend to more than one metre above the deck or which are fitted to decks above the datum need not be fitted with closing arrangements unless they face forward or are specifically required by the Administration.

2.2.8.4.3 Except as provided in 2.2.8.4.2, ventilator openings shall be provided with efficient weathertight closing appliances.

2.2.8.4.4 Ventilator openings shall face aft or athwartships wherever practicable.

2.2.9 Scuppers, inlets and discharges

2.2.9.1 Discharges led through the shell either from spaces below the datum or from within superstructures and deckhouses fitted above the datum shall be fitted with efficient and accessible means for preventing water from passing inboard. Normally each separate discharge shall have one automatic non-return valve with a positive means of closing it from a position above the datum. Where, however, the vertical distance from the design waterline to the inboard end of the discharge pipe exceeds 0.01 L, the discharge may have two automatic non-return valves without positive means of closing, provided that the inboard valve is always accessible for examination under service conditions. Where that vertical distance exceeds 0.02 L, a single automatic non-return valve without positive means of closing may be accepted. The means for operating the positive action valve shall be readily accessible and provided with an indicator showing whether the valve is open or closed.

2.2.9.2 Valves on scuppers from weathertight compartments included in the stability calculations shall be operable from the operating compartment.

2.2.9.3 In manned machinery spaces, main and auxiliary sea inlets and discharges in connection with the operation of machinery may be controlled locally. Such controls shall be readily accessible and shall be provided with indicators showing whether the valves are open or closed. In unmanned machinery spaces, main and auxiliary sea inlet and discharge controls in connection with the operation of machinery shall either:

- .1 be located at least 50% of the significant wave height corresponding to the worst intended conditions above the deepest flooded waterline following damage specified in 2.6.6 to 2.6.10; or
- .2 be operable from the operating compartment.

2.2.9.4 Scuppers leading from superstructures or deckhouses not fitted with weathertight doors shall be led overboard.

2.2.9.5 All shell fittings and the valves required by this Code shall be of a suitable ductile material. Valves of ordinary cast iron or similar material shall not be acceptable.

2.2.10 Air pipes

2.2.10.1 Main storage tanks containing flammable liquids or tanks which can be pumped or filled from the sea shall have air pipes which do not terminate in enclosed spaces.

2.2.10.2 All air pipes extending to exposed decks shall have a height from the deck to the point where water may have access below of at least 300 mm where the deck is less than 0.05L above the design waterline, and 150 mm on all other decks.

2.2.10.3 Air pipes may discharge through the side of the superstructure provided that this is at a height of at least 0.02L above any waterline when the intact craft is heeled to an angle of 15°, or 0.02L above the highest waterline at all stages of flooding as determined by the damaged stability calculations, whichever is higher.

2.2.10.4 All air pipes shall be equipped with weathertight closing devices that close automatically.

2.2.11 Freeing ports

- 2.2.11.1 Where bulwarks on weather decks form wells, ample provision shall be made for rapidly freeing the decks of water and for draining them. The minimum freeing port area (A) on each side of the craft for each well on the weather deck of the main hull(s) shall be:

- .1 where the length of bulwark (l) in the well is 20 m or less:

$$A = 0.7 + 0.035 l \text{ (m}^2\text{); and}$$

- .2 where l exceeds 20 m:

$$A = 0.07 l \text{ (m}^2\text{),}$$

and, in no case, l need be taken as greater than $0.7 L$.

If the bulwark is more than 1.2 m in average height, the required area shall be increased by 0.004 square metres per metre of length of well for each 0.1 metre difference in height. If the bulwark is less than 0.9 m in average height, the required area shall be decreased by 0.004 square metres per metre of length of well for each 0.1 metre difference in height.

2.2.11.2 Such freeing ports shall be located within the height of 0.6 m above the deck and the lower edge shall be within 0.02 m above the deck.

2.2.11.3 All such openings in the bulwarks shall be protected by rails or bars spaced approximately 230 mm apart. If shutters are fitted to freeing ports, ample clearance shall be provided to prevent jamming. Hinges shall have pins or bearings of non-corrodible material. If shutters are fitted with securing appliances, these appliances shall be of approved construction.

2.2.11.4 Craft, having superstructures which are open in front or both ends, shall comply with the provisions of 2.2.11.1.

2.2.11.5 In craft, having superstructures which are open at the aft end, the minimum freeing port area shall be:

$$A = 0.3 b \text{ (m}^2\text{)}$$

where:

$$b = \text{the breadth of the craft at the exposed deck (m).}$$

2.2.11.6 Ro-ro craft fitted with bow loading openings leading to open vehicle spaces shall comply with the provisions of 2.2.3.

2.3 Intact stability in the displacement mode

2.3.1 Hydrofoil craft fitted with surface-piercing foils and/or fully submerged foils shall have sufficient stability under all permitted cases of loading to comply with the relevant provisions of annex 6 and specifically maintain a heel angle of less than 10° when subjected to the greater of the heeling moments in 1.1.2 and 1.1.4 of that annex.

2.3.2 Subject to 2.3.4, multihull craft other than hydrofoil craft shall meet the relevant requirements of annex 7 in all permitted cases of loading.

2.3.3 Subject to 2.3.4, monohull craft other than hydrofoil craft shall meet the relevant requirements of annex 8 in all permitted conditions of loading.

2.3.4 Where the characteristics of multihull craft are inappropriate for application of annex 7 or the characteristics of monohull craft are inappropriate for application of annex 8, the Administration may accept alternative criteria equivalent to those stipulated, as appropriate to the type of craft and area of operation. The requirements of annexes 7 and 8 may be applied as indicated in the table below.

Table 2.3.4 – Application of annexes 7 and 8 to monohull and multihull craft

GM _T	Angle of maximum GZ	
	≤ 25 °	> 25 °
≤ 3 m	annex 7 or annex 8	annex 8
> 3 m	annex 7	annex 7 or annex 8

where:

GM_T = transverse metacentric height in the loading condition corresponding to the design water line, corrected for free surface effects (m)

GZ = righting lever

2.4 Intact stability in the non-displacement mode

2.4.1 The requirements of this section and section 2.12 shall be applied on the assumption that any stabilisation systems fitted are fully operational.

2.4.2 The roll and pitch stability on the first and/or any other craft of a series shall be qualitatively assessed during operational safety trials as required by chapters 17 and 18 and annex 9. The results of such trials may indicate the need to impose operational limitations.

2.4.3 Where craft are fitted with surface-piercing structure or appendages, precautions shall be taken against dangerous attitudes or inclinations and loss of stability subsequent to a collision with a submerged or floating object.

2.4.4 In designs where periodic use of cushion deformation is employed as a means of assisting craft control, or periodic use of cushion air exhausting to atmosphere for purposes of craft manoeuvring, the effects upon cushion-borne stability shall be determined, and the limitations on the use by virtue of craft speed or attitude shall be established.

2.4.5 In the case of an air cushion vehicle fitted with flexible skirts, it shall be demonstrated that the skirts remain stable under operational conditions.

2.5 Intact stability in the transitional mode

2.5.1 Under weather conditions up to the worst intended conditions, the time to pass from the displacement mode to the non-displacement mode and vice versa shall be minimised unless it is demonstrated that no substantial reduction of stability occurs during this transition.

2.5.2 Hydrofoil craft shall comply with the relevant provisions of annex 6.

2.6 Buoyancy and stability in the displacement mode following damage

2.6.1 The requirements of this section apply to all permitted conditions of loading.

2.6.2 For the purpose of making damage stability calculations, the volume and surface permeabilities shall be, in general, as follows:

Spaces	Permeability
Appropriated to cargo or stores	60
Occupied by accommodation	95
Occupied by machinery	85
Intended for liquids	0 or 95*
Appropriated for cargo vehicles	90
Void spaces	95

* whichever results in the more severe requirements

2.6.3 Notwithstanding 2.6.2, permeability determined by direct calculation shall be used where a more onerous condition results, and may be used where a less onerous condition results from that provided according to 2.6.2.

2.6.4 The Administration may permit the use of low-density foam or other media to provide buoyancy in void spaces, provided that satisfactory evidence is provided that any such proposed medium is the most suitable alternative and is:

- .1 of closed-cell form if foam, or otherwise impervious to water absorption;
- .2 structurally stable under service conditions;

- .3 chemically inert in relation to structural materials with which it is in contact or other substances with which the medium is likely to be in contact (reference is made to 7.4.3.7); and
- .4 properly secured in place and easily removable for inspection of the void spaces.

2.6.5 The Administration may permit void bottom spaces to be fitted within the watertight envelope of the hull without the provision of a bilge system or air pipes provided that:

- .1 the structure is capable of withstanding the pressure head after any of the damages required by this section;
- .2 when carrying out a damage stability calculation in accordance with the requirements of this section, any void space adjacent to the damaged zone shall be included in the calculation and the criteria in 2.6, 2.13 and 2.15 complied with;
- .3 the means by which water which has leaked into the void space is to be removed shall be included in the craft operating manual required by chapter 18; and
- .4 adequate ventilation is provided for inspection of the space under consideration as required by 2.2.1.2.
- .5 void spaces filled with foam or modular buoyancy elements or any space without a venting system are considered to be void spaces for the purposes of this paragraph, provided such foam or elements fully comply with 2.6.4.”

2.6.6 Any damage of a lesser extent than that postulated in 2.6.7 to 2.6.10, as applicable, which would result in a more severe condition shall also be investigated.

2.6.7 Extent of side damage

The following side damage shall be assumed anywhere on the periphery of the craft:

- .1 the longitudinal extent of damage shall be $0.75\nabla^{1/3}$, or $(3\text{ m} + 0.225 \nabla^{1/3})$, or 11 m, whichever is the least;
- .2 the transverse extent of penetration into the craft shall be $0.2\nabla^{1/3}$. However, where the craft is fitted with inflated skirts or with non-buoyant side structures, the transverse extent of

penetration shall be at least $0.12\nabla^{1/3}$ into the main buoyancy hull or tank structure; and

- .3 the vertical extent of damage shall be taken for the full vertical extent of the craft,

where:

∇ = volume of displacement corresponding to the design waterline (m^3).

The damages described in this paragraph shall be assumed to have the shape of a parallelepiped¹⁸. Applying this to figure 2.6.7 a, the inboard face at its mid-length shall be tangential to, or otherwise touching in a least 2 places, the surface corresponding to the specified transverse extent of penetration, as illustrated in figure 2.6.7 a.

Side damage shall not transversely penetrate a greater distance than the extent of $0.2\nabla^{1/3}$ at the design waterline, except where a lesser extent is provided for in 2.6.7.2. Refer to figures 2.6.7b and c.

If considering a multihull, the periphery of the craft is considered to only be the surface of the shell encompassed by the outboard surface of the outermost hull at any given section.

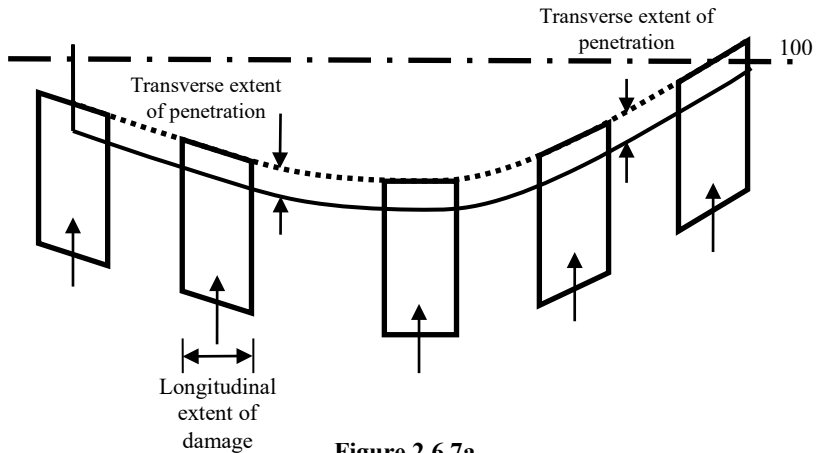

Figure 2.6.7a

¹⁸ A parallelepiped is defined as “a solid contained by parallelograms” and a parallelogram is defined as “a four-sided rectilinear figure whose opposite sides are parallel.”

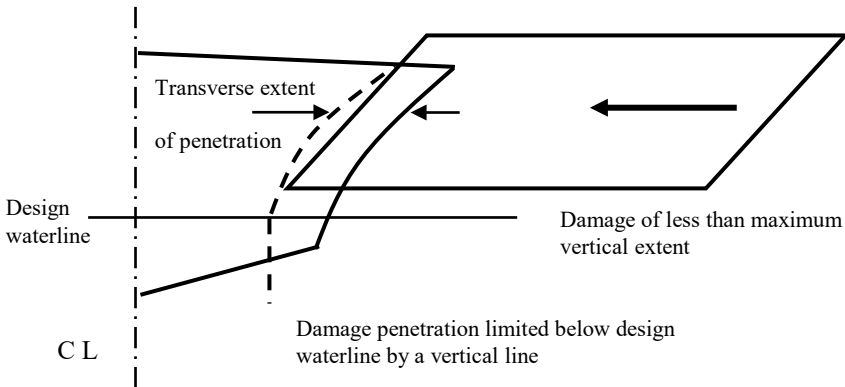

Figure 2.6.7 b

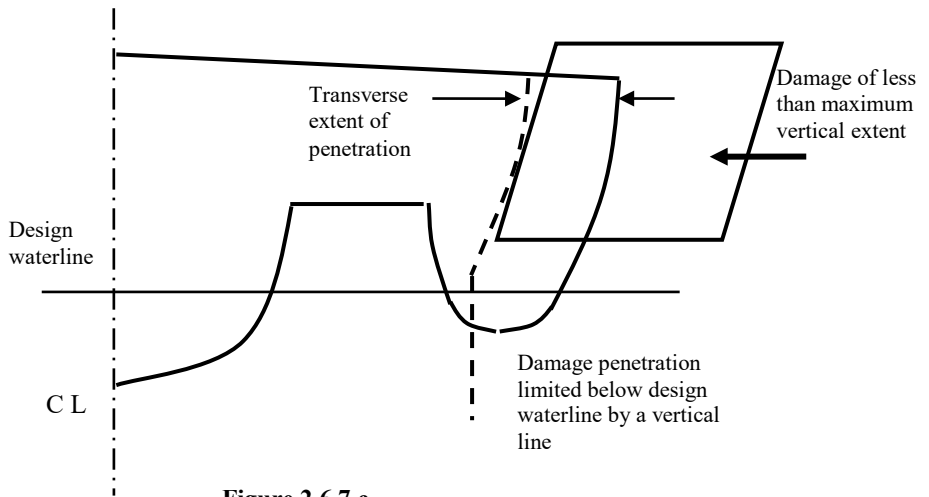

Figure 2.6.7 c

2.6.8 Extent of bow and stern damage

2.6.8.1 The following extents of damage are to be applied to bow and stern, as illustrated in figure 2.6.8:

- .1 at the fore end, damage to the area defined as A_{bow} in 4.4.1, the aft limit of which being a transverse vertical plane, provided that this area need not extend further aft from the forward extremity of the craft's watertight envelope than the distance defined in 2.6.7.1; and

- .2 at the aft end, damage to the area aft of a transverse vertical plane at a distance $0.2\bar{\nabla}^{1/3}$ forward of the aft extremity of the watertight envelope of the hull.

2.6.8.2 The provisions of 2.6.6 in relation to damage of lesser extent remain applicable to such damage.

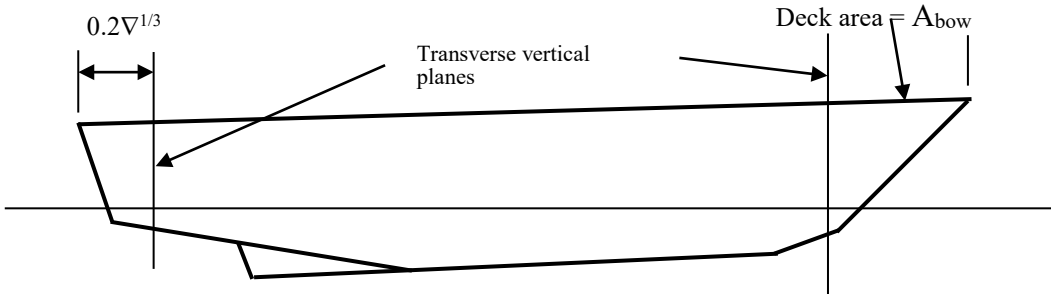

Figure 2.6.8

2.6.9 Extent of bottom damage in areas vulnerable to raking damage

2.6.9.1 Application

- .1 Any part of the surface of the hull(s) is considered to be vulnerable to raking damage if:
 - .1 it is in contact with the water at 90 % of maximum speed in smooth water, and
 - .2 it also lies below two planes which are perpendicular to the craft centreline plane and at heights as shown in figure 2.6.8.1.

For multihulls, individual hulls shall be considered separately.

- .2 Raking damage shall be assumed to occur along any fore-and-aft line on the surface of the hull(s) between the keel and the upper limit defined in the figure below:
- .3 Damage shall not be applied at the same time as that defined in 2.6.7 or 2.6.9.

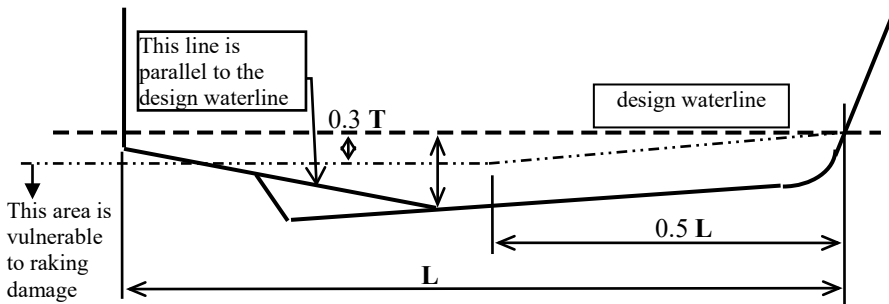

where: T = maximum draught of the hull (each hull considered individually in the case of multihulls) to the design waterline, excluding any non-buoyant structure, provided that structures such as single plate skegs or solid metal appendages shall be considered to be non-buoyant and thus excluded.¹⁹

Figure 2.6.9.1

2.6.9.2 Extent

2.6.9.2.1 Two different longitudinal extents shall be considered separately:

- .1 55% of the length L , measured from the most forward point of the underwater buoyant volume of each hull; and
- .2 a percentage of the length L , applied anywhere in the length of the craft, equal to 35% for craft where $L = 50\text{m}$ and over and equal to $(L/2 + 10)\%$ for craft where L is less than 50m.

2.6.9.2.2 Except as provided below, the penetration normal to the shell shall be $0.04\nabla^{1/3}$ or 0.5 m, whichever is the lesser, in association with a girth along the shell equal to $0.1\nabla^{1/3}$, where ∇ is the volume of displacement corresponding to the design waterline (m^3). However this penetration or girth shall under no circumstances extend above the vertical extent of the vulnerable area as specified in 2.6.8.1.1.

2.6.9.2.3 The shape of damage shall be assumed to be rectangular in the transverse plane as illustrated in figure 2.6.9.2 below. Damage is to be assumed at a series of sections within the defined longitudinal extent in

¹⁹ Enligt MSC 82/24/Add.1 skulle denna ändring placeras i 2.6.9.1.2.

accordance with figure 2.6.9.2, the mid-point of the damaged girth being maintained at a constant distance from the centreline throughout that longitudinal extent.

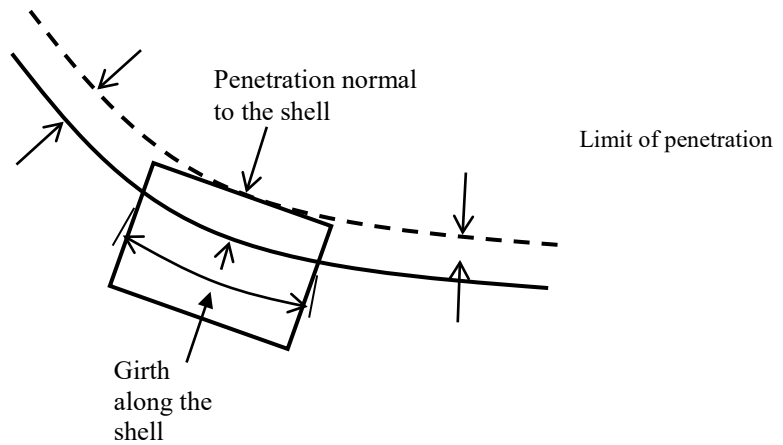

Figure 2.6.9.2

2.6.10 Extent of bottom damage in areas not vulnerable to raking damage

2.6.10.1 Application

This applies to all parts of the hull(s) below the design waterline which are not defined as vulnerable to raking damage in 2.6.8.1. Damage shall not be applied at the same time as that defined in 2.6.7 or 2.6.8.

2.6.10.2 Extent

The following extent of damage shall be assumed:

- .1 the length of damage in the fore-and-aft direction shall be $0.75\nabla^{1/3}$, or $(3 \text{ m} + 0.225\nabla^{1/3})$, or 11 m whichever is the least;
- .2 the athwartships girth of damage shall be $0.2\nabla^{1/3}$; and
- .3 the depth of penetration normal to the shell shall be $0.02\nabla^{1/3}$,

where:

∇ = volume of displacement corresponding to the design waterline (m^3).

- .4 the shape of damage shall be assumed to be rectangular in the plane of the shell of the craft, and rectangular in the transverse plane as illustrated in figure 2.6.9.2.

2.6.11 In applying 2.6.8 and 2.6.9 to multihull craft, an obstruction at or below the design waterline of up to 7 m width shall be considered in determining the number of hulls damaged at any one time. The requirement of 2.6.6 shall also be applied.

2.6.12 Following any of the postulated damages detailed in 2.6.6 to 2.6.10, the craft in still water shall have sufficient buoyancy and positive stability to simultaneously ensure that:

- .1 for all craft other than amphibious air-cushion vehicles, after flooding has ceased and a state of equilibrium has been reached, the final waterline is below the level of any opening through which further flooding could take place by at least 50% of the significant wave height corresponding to the worst intended conditions;
- .2 for amphibious air-cushion vehicles, after flooding has ceased and a state of equilibrium has been reached, the final waterline is below the level of any opening through which further flooding could take place by at least 25% of the significant wave height corresponding to the worst intended conditions;
- .3 there is a positive freeboard from the damage waterline to survival craft embarkation positions;
- .4 essential emergency equipment, emergency radios, power supplies and public address systems needed for organizing the evacuation remain accessible and operational;
- .5 the residual stability of craft meets the appropriate criteria as laid out in annexes 7 and 8 according to table 2.3.4. Within the range of positive stability governed by the criteria of annexes 7 or 8, no unprotected opening shall be submerged.

2.6.13 Downflooding openings referred to in 2.6.11.1 and 2.6.11.2 shall include doors and hatches which are used for damage control or evacuation procedures, but may exclude those which are closed by means of weathertight doors and hatch covers and not used for damage control or evacuation procedures.

2.7 Inclining and stability information

2.7.1 Every craft, on completion of build, shall be inclined and the elements of its stability determined. When an accurate inclining is not practical, the lightweight displacement and centre of gravity shall be determined by a lightweight survey and accurate calculation.

2.7.2 On all craft, where an accurate inclining experiment is impractical owing to the height of the centre of gravity (VCG or KG) being less than one third of the transverse metacentric height (GM_T), the Administration may accept estimation of KG by detailed calculation in place of an inclining experiment. In such cases, a displacement check shall be undertaken to confirm the calculated lightship characteristics, including LCG, which may be accepted if the measured lightship displacement and LCG are respectively within 2% and 1% L relative to the estimate.

2.7.3 The master shall be supplied by the owner with reliable information relating to the stability of the craft in accordance with the following provisions of this paragraph. The information relating to stability shall, before issued to the master, be submitted to the Administration for approval, together with a copy thereof for their retention, and shall incorporate such additions and amendments as the Administration may in any particular case require.

2.7.4 Where any alterations are made to a craft so as significantly to affect the stability information supplied to the master, amended stability information shall be provided. If necessary the craft shall be re-inclined.

2.7.5 A report of each inclining or lightweight survey carried out in accordance with this chapter and of the calculation therefrom of the lightweight condition particulars shall be submitted to the Administration for approval, together with a copy for their retention. The approved report shall be placed on board the craft by the owner in the custody of the master and shall incorporate such additions and amendments as the Administration may in any particular case require. The amended lightweight condition particulars so obtained from time to time shall be used by the master in substitution for such previously approved particulars when calculating the craft's stability.

2.7.6 Following any inclining or lightweight survey, the master shall be supplied with amended stability information if the Administration so requires. The information so supplied shall be submitted to the Administration for approval, together with a copy thereof for their retention, and shall incorporate such additions and amendments as the Administration may in any particular case require.

2.7.7 Stability information demonstrating compliance with this chapter shall be furnished in the form of a stability information book which shall be kept on board the craft at all times in the custody of the master. The information shall include particulars appropriate to the craft and shall reflect the craft loading conditions and mode of operation. Any enclosed

superstructures or deck-houses included in the cross curves of stability and the critical downflooding points and angles shall be identified. At the operating station there shall be plans showing clearly for each deck and hold the boundaries of the watertight compartments, the openings therein with their means of closure and position of any controls thereof. For amphibious air-cushion vehicles this may be achieved by the use of draught gauges in conjunction with deck datum plates.

2.7.8 Every craft shall have scales of draughts marked clearly at the bow and stern. In the case where the draught marks are not located where they are easily readable, or operational constraints for a particular trade make it difficult to read the draught marks, then the craft shall also be fitted with a reliable draught-indicating system by which the bow and stern draughts can be determined.

2.7.9 The owner or builder, as appropriate, shall ensure that the positions of the draught marks are accurately determined and that the marks are located on the hull in a permanent manner. Accuracy of the draught marks shall be demonstrated to the Administration prior to the inclining experiment.

2.8 Loading and stability assessment

On completion of loading of the craft and prior to its departure on a voyage, the master shall determine the trim and stability of the craft and also ascertain and record that the craft is in compliance with stability criteria of the relevant requirements. The Administration may accept the use of an electronic loading and stability computer or equivalent means for this purpose.

2.9 Marking and recording of the design waterline

2.9.1 The design waterline shall be clearly and permanently marked on the craft's outer sides by the load line mark described below. This and the reference line described in 2.9.2.2 below shall be recorded in the High-Speed Craft Safety Certificate. For craft where this is not practical, e.g. amphibious air-cushion vehicles fitted with peripheral skirts, defined deck reference points shall be provided, from which the freeboard can be measured, and hence the draughts obtained.

2.9.2 Load line mark

2.9.2.1 The load line mark shall consist of a ring with an outside diameter of 300 mm and width of 25 mm which is intersected by a horizontal line of length 450 mm and having a breadth of 25 mm, the upper edge of which passes through the centre of the ring. The centre of the ring shall be placed at the longitudinal centre of flotation in the displacement mode and at a height corresponding to the design waterline.

2.9.2.2 To assist in verifying the position of the load line mark, a reference line shall be marked on the hull at the longitudinal centre of flotation by a horizontal bar having a length of 300 mm and a breadth of 25 mm and having the upper edge corresponding to the reference line.

2.9.2.3 Where practicable, the reference line should be related to the uppermost deck at side. Where it is not possible, the position of the reference line should be defined from the underside of keel at the longitudinal centre of flotation.

2.9.2.4 The mark of the Authority by whom the load lines are assigned may be indicated alongside the load line ring above the horizontal line which passes through the centre of the ring, or above and below it. This mark shall consist of not more than four initials to identify the Authority's name, each measuring approximately 115 mm in height, and 75 mm in width.

2.9.2.5 The ring, lines and letters shall be painted in white or yellow on a dark ground or in black on a light ground, and permanently marked. The marks shall be plainly visible.

2.9.3 Verification

The High-Speed Craft Safety Certificate shall not be delivered until the Administration has verified that the marks are correctly and permanently indicated on the sides of the craft.

PART B - REQUIREMENTS FOR PASSENGER CRAFT

2.10 General

2.10.1 Where compliance with this chapter requires consideration of the effects of passenger weight, the following information shall be used:

- .1 The distribution of passengers is 4 persons per square metre.
- .2 Each passenger has a mass of 75 kg.
- .3 Vertical centre of gravity of seated passengers is 0.3 m above seat.
- .4 Vertical centre of gravity of standing passengers is 1.0 m above deck.
- .5 Passengers and luggage shall be considered to be in the space normally at their disposal.
- .6 Passengers shall be distributed on available deck areas towards one side of the craft on the decks where assembly stations are located and in such a way that they produce the most adverse heeling moment.
- .7 Passengers assumed to be occupying seats shall be taken as having a vertical centre of gravity corresponding to being seated, with all others standing.
- .8 On the decks where assembly stations are located, the number of passengers on each deck shall be that which generates the maximum heeling moment. Any remaining passengers shall be assumed to occupy decks adjacent to those on which the assembly stations are located, and positioned such that the combination of number on each deck and total heeling moment generate the maximum static heel angle.
- .9 Passengers shall not be assumed to gain access to the weather deck nor be assumed to crowd abnormally towards either end of the craft unless this is a necessary part of the planned evacuation procedure.
- .10 Where there are seats in areas occupied by passengers, one passenger per seat shall be assumed, passengers being assigned to the remaining free areas of the deck (including stairways, if appropriate) at the rate of four per square metre.

2.11 Intact stability in the displacement mode

The craft shall have sufficient intact stability that, when in still water conditions, the inclination of the craft from the horizontal would not exceed 10° (under all permitted cases of loading and uncontrolled passenger movements as may occur).

2.12 Intact stability in the non-displacement mode

2.12.1 The total heel angle in still water due to the effect of passenger movements or due to beam wind pressure as per 1.1.4 of annex 6 shall not to exceed 10°. Passenger movement need not be considered where passengers are required to be seated whenever the craft is operating in the non-displacement mode.

2.12.2 In all loading conditions, the outward heel due to turning shall not exceed 8°, and the total heel due to beam wind pressure as per 1.1.4 of annex 6 and due to turning shall not exceed 12° outward.

2.12.3 Demonstrating the effect of the passenger heeling moment calculated as given by 2.10 above, or a defined beam wind pressure when at speed, shall be established by conducting a trial or model test with an equivalent heeling moment applied by test weights. Passenger movement may only be neglected on craft where the safety announcement (refer to 8.4.1 and 18.7) expressly requires passengers to remain seated throughout the voyage.

2.13 Buoyancy and stability in the displacement mode following damage

2.13.1 Following any of the postulated damages detailed in 2.6.6 to 2.6.10, in addition to satisfying the requirements of 2.6.11 and 2.6.12, the craft in still water shall have sufficient buoyancy and positive stability to simultaneously ensure that:

- .1 the angle of inclination of the craft from the horizontal does not normally exceed 10° in any direction. However, where this is clearly impractical, angles of inclination up to 15° immediately after damage but reducing to 10° within 15 min shall be permitted provided that efficient non-slip deck surfaces and suitable holding points, e.g., holes, bars, etc., are provided; and
- .2 any flooding of passenger compartments or escape routes which might occur will not significantly impede the evacuation of passengers.

2.13.2 In addition to the requirements in 2.13.1, category B craft shall also satisfy the following criteria after sustaining raking damage of 100% of

length L , having the girth and penetration given in 2.6.8.2.2, to any part of the surface of the hull(s) defined in 2.6.8.1:

- .1 The angle of inclination of the craft from the horizontal shall not exceed 20° in the equilibrium condition;
- .2 the range of positive righting lever shall be at least 15° in the equilibrium condition;
- .3 the positive area under the righting lever curve shall be at least 0.015 m-rad in the equilibrium condition;
- .4 the requirements of 2.6.11.3 and 2.13.1.2 are satisfied; and
- .5 in intermediate stages of flooding, the maximum righting lever shall be at least 0.05 m and the range of positive righting lever shall be at least 7° .

In complying with the above, the righting lever curve shall be terminated at the angle of downflooding, and only one free surface need be assumed.

2.14 Inclining and stability information

2.14.1 At periodical intervals not exceeding 5 years, a lightweight survey shall be carried out on all passenger craft to verify any changes in lightweight displacement and longitudinal centre of gravity. The passenger craft shall be re-inclined whenever, in comparison with the approved stability information, a deviation from the lightweight displacement exceeding 2%, or a deviation of the longitudinal centre of gravity exceeding 1% of L is found or anticipated.

2.14.2 A report of each inclining or lightweight survey carried out in accordance with paragraph 2.7.1 and of the calculation therefrom of the lightweight condition particulars shall be submitted to the Administration for approval, together with a copy for their retention. The approved report shall be placed on board the craft by the owner in the custody of the master and shall incorporate such additions and amendments as the Administration may in any particular case require. The amended lightweight condition particulars so obtained from time to time shall be used by the master in substitution for such previously approved particulars when calculating the craft's stability.

2.14.3 Following any inclining or lightweight survey, the master shall be supplied with amended stability information if the Administration so requires. The information so supplied shall be submitted to the Administration for approval, together with a copy thereof for their retention, and shall incorporate such additions and amendments as the Administration may in any particular case require.

PART C - REQUIREMENTS FOR CARGO CRAFT

2.15 Buoyancy and stability in the displacement mode following damage

Following any of the postulated damages detailed in 2.6.6 to 2.6.10, in addition to satisfying the requirements of 2.6.11 and 2.6.12, the craft in still water shall have sufficient buoyancy and positive stability to simultaneously ensure that the angle of inclination of the craft from the horizontal does not normally exceed 15° in any direction. However, where this is clearly impractical, angles of inclination up to 20° immediately after damage but reducing to 15° within 15 minutes may be permitted provided that efficient non-slip deck surfaces and suitable holding points are provided.

2.16 Inclining

Where it is satisfied by lightweight survey, weighing or other demonstration that the lightweight of a craft is closely similar to that of another craft of the series to which 2.7.1 has been applied, the Administration may waive the requirement of 2.7.1 for craft to be inclined. In this regard, a craft which lies within the parameters of 2.14.1, when compared with a craft of the series which has been inclined, shall be regarded as being closely similar to that craft.

CHAPTER 3

Structures

3.1 General

This chapter covers those elements of hull and superstructure which provide longitudinal and other primary and local strength of the craft as a whole and also other important components such as foils and skirts which are directly associated with the hull and superstructure.

3.2 Materials

Materials used for the hull and superstructure and the other features referred to in 3.1 shall be adequate for the intended use of the craft.

3.3 Structural strength

The structure shall be capable of withstanding the static and dynamic loads which can act on the craft under all operating conditions in which the craft is permitted to operate, without such loading resulting in inadmissible deformation and loss of watertightness or interfering with the safe operation of the craft.

3.4 Cyclic loads

Cyclic loads, including those from vibrations which can occur on the craft, shall not:

- .1 impair the integrity of structure during the anticipated service life of the craft or the service life agreed with the Administration;
- .2 hinder normal functioning of machinery and equipment; and
- .3 impair the ability of the crew to carry out its duties.

3.5 Design criteria

The Administration shall be satisfied that the choice of design conditions, design loads and accepted safety factors corresponds to the intended operating conditions for which certification is sought.

3.6 Trials

If the Administration consider it necessary, it shall require full-scale trials to be undertaken in which loadings are determined. Cognisance shall be taken of the results where these indicate that loading assumptions of structural calculations have been inadequate.

CHAPTER 4

Accommodation and Escape Measures

4.1 General

4.1.1 Public spaces and crew accommodation shall be designed and arranged so as to protect the occupants from unfavourable environmental conditions and to minimize the risk of injury to occupants during normal and emergency conditions.

4.1.2 Spaces accessible to passengers shall not contain controls, electrical equipment, high-temperature parts and pipelines, rotating assemblies or other items, from which injury to passengers could result, unless such items are adequately shielded, isolated, or otherwise protected.

4.1.3 Public spaces shall not contain operating controls unless the operating controls are so protected and located that their operation by a crew member shall not be impeded by passengers during normal and emergency conditions.

4.1.4 Windows in passenger and crew accommodation shall be of adequate strength and suitable for the worst intended conditions specified in the Permit to Operate and be made of material which will not break into dangerous fragments if fractured.

4.1.5 The public spaces, crew accommodation and the equipment therein shall be designed so that each person making proper use of these facilities will not suffer injury during craft's normal and emergency start, stop and manoeuvring in normal cruise and in failure or maloperation conditions.

4.2 Public address and information system

4.2.1 A general emergency alarm system shall be provided. The alarm shall be audible throughout all the public spaces, corridors and stairways, crew accommodation and normal crew working spaces and open decks, and the sound pressure level shall be at least 10 dB(A) above ambient noise levels under way in normal cruise operation. The alarm shall continue to function after it has been triggered until it is normally turned off or is temporarily interrupted by a message on the public address system.

4.2.2 There shall be a public address system covering all areas where passengers and crew have access, escape routes, and places of embarkation into survival craft. The system shall be such that flooding or fire in any compartment does not render other parts of the system inoperable. The

public address system and its performance standards shall be approved by the Administration having regard to the recommendations developed by the Organization²⁰.

4.2.3 All passenger craft shall be equipped with illuminated or luminous notices or video information system(s) visible to all sitting passengers, in order to notify them of safety measures.

4.2.4 The master shall, by means of the public address system and the visual information system, be able to request passengers "please be seated" when found to be appropriate to safeguard passengers and always when the safety level 1 according to table 1 of annex 3 is exceeded.

4.3 Design acceleration levels

4.3.1 For passenger craft, superimposed vertical accelerations above 1.0 g at longitudinal centre of gravity shall be avoided unless special precautions are taken with respect to passenger safety.

4.3.2 Passenger craft shall be designed for the collision design acceleration g_{coll} with respect to the safety in, and escape from, the public spaces, crew accommodation and escape routes, including in way of life-saving appliances and emergency source of power. The size and type of craft together with speed, displacement and building material shall be taken into consideration when the collision load is determined. The collision design condition shall be based on head-on impact at a defined collision speed.

4.3.3 Mounting of large masses such as main engines, auxiliary engines, lift fans, transmissions and electrical equipment shall be proved by calculation to withstand, without fracturing, the design acceleration given in table 4.3.3.

²⁰ Refer to the Recommendations on performance standards for public address systems on passenger ships, including cabling (MSC/Circ.808) and the Code on Alarms and Indicators, 1995 (resolution A.830(19)).

Table 4.3.3 - Design acceleration as multiples of g

Direction \ Types of craft	All HSC except amphibious ACVs	Amphibious ACVs
Forward direction	g_{coll}	6
After direction	2 or g_{coll} if less	3
Transverse direction	2 or g_{coll} if less	3
Vertical direction	2 or g_{coll} if less	3

where:

g_{coll} = the collision design acceleration expressed as a multiple of the acceleration due to gravity (9.806 m/s²)

4.3.4 Collision design acceleration g_{coll} (for craft other than amphibious ACVs where $g_{coll} = 6$) shall be calculated as follows:

$$g_{coll} = 1.2 \left(\frac{P}{g \cdot \Delta} \right), \text{ but not to be taken greater than 12,}$$

where the load P shall be taken as the lesser of P₁ and P₂, where:

$$P_1 = 460 (M \cdot C_L)^{2/3} (E \cdot C_H)^{1/2}$$

$$P_2 = 9000 \cdot M \cdot C_L (C_H D)^{1/2}$$

where the hull material factor M shall be taken as:

$$M = 1.3 \text{ for high tensile steel}$$

$$M = 1.0 \text{ for aluminium alloy}$$

$$M = 0.95 \text{ for mild steel}$$

$$M = 0.8 \text{ for fibre-reinforced plastics,}$$

where the length factor C_L of the craft is:

$$C_L = \frac{(165 + L)}{245} \left(\frac{L}{80} \right)^{0.4}$$

where the height factor $C_H = (80 - L)/45$ but not greater than 0.75 or less than 0.3,

where the kinetic energy of the craft at speed V_{imp} is:

$$E = 0.5 \Delta \cdot V_{imp}^2$$

where the main particulars of the craft are:

- L = craft length as defined in chapter 1 (m)
- D = depth of the craft from the underside of keel to the top of the effective hull girder (m)
- Δ = craft displacement, being the mean of the lightweight and maximum operational weight (t)
- V_{imp} = estimated impact speed (m/s) = 60 % of maximum speed
- g = acceleration due to gravity = 9.806 m/s².

For hydrofoils, the collision design acceleration, g_{coll} shall be taken as the greater of either the g_{coll} as calculated above or:

$$g_{coll} = F/(g \cdot \Delta)$$

where:

- F = failure load of bow foil assembly applied at the operational waterline (kN).

4.3.5 As an alternative to the requirements of 4.3.4, the collision design acceleration g_{coll} may be determined by carrying out a collision load analysis of the craft on a vertical rock having a maximum height of 2 m above the waterline and using the same assumption for displacement Δ and impact speed V_{imp} as described in 4.3.4. This evaluation may be carried out as part of the safety analysis. If the collision design accelerations are determined by both 4.3.4 and the collision load analysis, the lower resulting value may be used as the collision design acceleration.

4.3.6 Compliance with the provisions of 4.1.5 and 4.3.1 shall be shown for the actual type of craft, as described in annex 9.

4.3.7 Limiting sea states for operation of the craft shall be given in normal operation condition and in the worst intended conditions, at 90 % of the maximum speed and at reduced speed as necessary.

4.4 Accommodation design

4.4.1 The public spaces, control stations and crew accommodation of high-speed craft shall be located and designed to protect passengers and crew in the design collision condition. In this respect, these spaces shall not be located forward of a transverse plane (see figure 4.4.1) such that:

where: $A_{bow} = 0.0035 A m f V$, but never less than $0.04 A$,

A_{bow} = the plan projected area of craft energy absorbing structure forward of the transverse plane (m^2)

A = total plan projected area of craft (m^2)

m = material factor = $\frac{0.95}{M}$

M = appropriate hull material factor as given in 4.3.4

Where materials are mixed, the material factor shall be taken as a weighted mean, weighted according to the mass of material in the area defined by A_{bow} .

f = framing factor as follows:

- longitudinal deck and shell stiffening = 0.8
- mixed longitudinal and transverse = 0.9
- transverse deck and shell stiffening = 1.0

V = 90 % of the maximum (m/s).

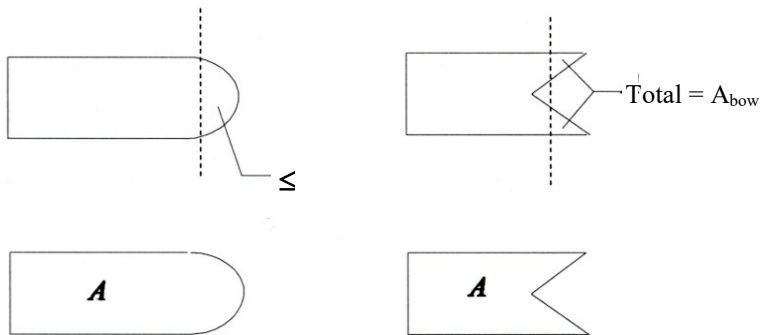

Figure 4.4.1: Plan view of two different craft styles

4.4.2 The public spaces and crew accommodation shall be designed based on the guidelines given in table 4.4.2 or by other methods which have been proven to give equal protective qualities.

4.4.3 Equipment and baggage in public spaces and in the operator's compartment shall be positioned and secured so that they remain in the stowed position when exposed to the collision design acceleration according to 4.3.4, 4.3.5 and table 4.3.3.

4.4.4 Seats, life-saving appliances and items of substantial mass and their supporting structure shall not deform or dislodge under any loads up to those specified in 4.3.4, 4.3.5 and table 4.3.3 in any manner that would impede subsequent rapid evacuation of passengers.

4.4.5 There shall be adequate handholds on both sides of any passage to enable passengers to steady themselves while moving about. The armrests and backrests of seats in public spaces may serve as handholds.

Table 4.4.2 - Overview general design guidelines²¹

Design level 1: g_{coll} less than 3	
1	Seat/seat belts
1.1	Low or high seatback
1.2	No restrictions on seating direction
1.3	Sofas allowed
1.4	No seat belts requirement
2	Tables in general allowed
3	Padding of projecting objects
4	Kiosks, bars, etc., no special restrictions
5	Baggage, no special requirements
6	Large masses, restraint and positioning
Design level 2: $g_{coll} = 3$ to 12	
1	Seat/seat belts
1.1	Seatbacks with protective deformation and padding
1.2	Forward or backward seating direction
1.3	No sofas allowed as seat
1.4	Lap belt in seats when no protective structure forward unless satisfactorily tested without belts in that orientation and arrangement
2	Tables with protective features allowed. Dynamic testing
3	Padding of projecting objects
4	Kiosks, bars, etc., on aft side of bulkheads, or other specially approved arrangements
5	Baggage placed with protection forward
6	Large masses, restraint and positioning

²¹ Other arrangements may be employed if an equivalent level of safety is achieved.

4.5 Seating construction

4.5.1 A seat shall be provided for each passenger and crew member for which the craft is certified to carry. Such seats shall be arranged in enclosed spaces.

4.5.2 Seats fitted in addition to those required under 4.5.1 and which are not permitted to be used in hazardous navigational situations or potentially dangerous weather or sea conditions need not comply with 4.5 or 4.6. Such seats shall be secured according to 4.4.4 and clearly identified as not being able to be used in hazardous situations.

4.5.3 The installation of seats shall be such as to allow adequate access to any part of the accommodation space. In particular, they shall not obstruct access to, or use of, any essential emergency equipment or means of escape.

4.5.4 Seats and their attachments, and the structure in the proximity of the seats, shall be of a form and design, and so arranged, such as to minimize the possibility of injury and to avoid trapping of the passengers after the assumed damage in the collision design condition according to 4.4.1. Dangerous projections and hard edges shall be eliminated or padded.

4.5.5 Seats, seat belts, seat arrangements and adjacent parts such as tables shall be designed for the actual collision design acceleration as specified in 4.3.4.

4.5.6 All seats, their supports and their deck attachments shall have good energy-absorbing characteristics and shall meet the requirements of annex 10.

4.6 Safety belts

4.6.1 One-hand-release safety belts of three-point type or with shoulder harness shall be provided for all seats from which the craft may be operated for all craft with the g_{coll} acceleration from the collision design acceleration exceeding 3, as prescribed in 4.3.4.

4.6.2 Safety belts shall be provided on passenger seats and crew seats, if necessary, to obtain the protective performance measures described in annex 10.

4.7 Exits and means of escape

4.7.1 In order to ensure immediate assistance from the crew in an emergency situation, the crew accommodation, including any cabins, shall be located with due regard to easy, safe and quick access to the public spaces from inside the craft. For the same reason, easy, safe and quick

access from the operating compartment to the public spaces shall be provided.

4.7.2 The design of the craft shall be such that all occupants may safely evacuate the craft into survival craft under all emergency conditions, by day or by night. The positions of all exits which may be used in an emergency, and of all life-saving appliances, the practicability of the evacuation procedure, and the evacuation time to evacuate all passengers and crew shall be demonstrated.

4.7.3 Public spaces, evacuation routes, exits, lifejacket stowage, survival craft stowage, and the embarkation stations shall be clearly and permanently marked and illuminated as required in chapter 12.

4.7.4 Each enclosed public space and similar permanently enclosed space allocated to passengers or crew shall be provided with at least two exits as widely separated as practical. All exits shall clearly indicate the directions to the evacuation station and safe areas. On category A craft and cargo craft, at least one exit shall give access to the evacuation station serving the persons in the enclosed space considered, and all other exits shall give access to a position on the open deck from which access to an evacuation station is provided. On category B craft, exits shall provide access to the alternative safe area required by 7.11.1; external routes may be accepted providing that the requirements of 4.7.3 and 4.7.11 are complied with.

4.7.5 Subdivision of public spaces to provide refuge in case of fire may be required in compliance with 7.4.4.1 and 7.11.1.

4.7.6 Exit doors shall be capable of being readily operated from inside and outside the craft in daylight and in darkness. The means of operation shall be obvious, rapid and of adequate strength. Doors along escape routes should, wherever appropriate, open in the direction of escape flow from the space served.

4.7.7 The closing, latching and locking arrangements for exits shall be such that it is readily apparent to the appropriate crew member when the doors are closed and in a safe operational condition, either in direct view or by an indicator. The design of external doors shall be such as to minimize the possibility of jamming by ice or debris.

4.7.8 The craft shall have a sufficient number of exits which are suitable to facilitate the quick and unimpeded escape of persons wearing approved lifejackets in emergency conditions, such as collision damage or fire.

4.7.9 Sufficient space for a crew member shall be provided adjacent to exits for ensuring the rapid evacuation of passengers.

4.7.10 All exits, together with their means of opening, shall be adequately marked for the guidance of passengers. Clear markings, including the

location of the fire control plan, shall be provided for the guidance of rescue personnel outside the craft.

4.7.11 Footholds, ladders, etc., provided to give access from the inside to exits shall be of rigid construction and permanently fixed in position. Permanent handholds shall be provided whenever necessary to assist persons using exits, and shall be suitable for conditions when the craft has developed any possible angles of list or trim.

4.7.12 At least two unobstructed evacuation paths shall be available for the use of each person. Evacuation paths shall be disposed such that adequate evacuation facilities will be available in the event of any likely damage or emergency conditions, and evacuation paths shall have adequate lighting supplied from the main and emergency sources of power. Doors providing escape from a space shall, where possible, be situated at opposite ends of the space. Where the doors providing escape from a space are situated in the same end of the space, the distance between those doors shall be greater than the maximum length of the space.

4.7.13 The width of corridors, doorways and stairways which form part of the evacuation paths shall be not less than 900 mm for passenger craft and 700 mm for cargo craft. This width may be reduced to 600 mm for corridors, doorways and stairways serving spaces where persons are not normally employed. There shall be no protrusions in evacuation paths which could cause injury, ensnare clothing, damage lifejackets or restrict evacuation of disabled persons. Requirements of this paragraph do not apply to aisles (fore-aft passageways separating seating areas) or to spaces between adjacent rows of seats. However, the width of aisles and the seat pitch shall be such as to allow the craft to comply with the provisions of 4.8.

4.7.14 Special category spaces used for stowage of motor vehicles shall be provided with walkways having a width of at least 600 mm leading to a safe means of escape.

4.7.15 Adequate notices shall be provided to direct passengers to exits.

4.7.16 Provision shall be made on board for embarkation stations to be properly equipped for evacuation of passengers into life-saving appliances. Such provision shall include handholds, anti-skid treatment of the embarkation deck, and adequate space which is clear of cleats, bollards and similar fittings.

4.7.17 Main propulsion machinery spaces and ro-ro spaces shall be provided with two means of escape leading to a position outside the spaces from which a safe route to the evacuation stations is available. One means of escape from the main propulsion machinery spaces shall avoid direct access to any ro-ro space. Main propulsion machinery spaces having a length of less than 5 m and not being routinely entered or continuously manned, may be provided with a single means of escape. At least one means of escape from a machinery space shall consist of either a ladder leading to a door or hatch (not being a horizontal flush-hatch) or a door located in the lower part

of that space and giving access to an adjacent compartment from which a safe means of escape is provided.

4.7.18 Spaces that are only entered occasionally by crew members may have only one means of escape provided that it is independent of watertight doors.

4.8 Evacuation time

4.8.1 The provisions for evacuation shall be designed such that the craft can be evacuated under controlled conditions in a time of one third of the structural fire protection time (SFP) provided in 7.4.2 for areas of major fire hazard areas after subtracting a period of 7 min for initial detection and extinguishing action.

$$\text{Evacuation time} = \frac{(\text{SFP} - 7)}{3} \text{ (min)}$$

where:

SFP = structural fire protection time (min)

In determining the evacuation time, all means of escape are to be considered serviceable and they need not be dimensioned to take into account any additional number of persons that might be diverted from other means of escape if one or more of those other means of escape are lost or rendered unserviceable.

4.8.2 An evacuation procedure, including an evacuation analysis carried out taking into account the guidelines developed by the Organization²² shall be developed for the information of the Administration in connection with the approval of fire insulation plans and for assisting the owners and builders in planning the evacuation demonstration required in 4.8.3. The evacuation procedures shall include:

- .1 the emergency announcement made by the master;
- .2 contact with base port;
- .3 the donning of lifejackets;
- .4 manning of survival craft and emergency stations;
- .5 the shutting down of machinery and oil fuel supply lines;

²² Refer to the Guidelines for a simplified evacuation analysis of high-speed passenger craft (MSC/Circ.1166).

- .6 the order to evacuate;
- .7 the deployment of survival craft and marine escape systems and rescue boats;
- .8 the bowing in of survival craft;
- .9 the supervision of passengers;
- .10 the orderly evacuation of passengers under supervision;
- .11 crew checking that all passengers have left the craft;
- .12 the evacuation of crew;
- .13 releasing the survival craft from the craft; and
- .14 the marshalling of survival craft by the rescue boat, where provided.

4.8.3 Achievement of the required evacuation time (as ascertained in accordance with 4.8.1) shall be verified by a practical demonstration conducted under controlled conditions in the presence of the Administration, and shall be fully documented and verified for passenger craft by the Administration.

4.8.4 Evacuation demonstrations shall be carried out with due concern for the problems of mass movement or panic acceleration likely to arise in an emergency situation when rapid evacuation is necessary. The evacuation demonstrations shall be dry shod with the survival craft initially in their stowed positions and be conducted as follows:

- .1 The evacuation time on a category A craft shall be the time elapsed from the moment the first abandon craft announcement is given, with any passengers distributed in a normal voyage configuration, until the last person has embarked in a survival craft, and shall include the time for passengers and crew to don lifejackets.
- .2 The evacuation time on a category B craft and cargo craft shall be the time elapsed from the moment the order to abandon the craft is given until the last person has embarked in a survival craft. Passengers and crew may be wearing lifejackets and prepared for evacuation, and they may be distributed among assembly stations.
- .3 For all craft the evacuation time shall include the time necessary to launch, inflate and secure the survival craft alongside ready for embarkation.

4.8.5 The evacuation time shall be verified by an evacuation demonstration which shall be performed using the survival craft and exits on one side, for which the evacuation analysis indicates the greatest evacuation time, with the passengers and crew allocated to them.

4.8.6 On craft where a half trial is impracticable, the Administration may consider a partial evacuation trial using a route which the evacuation analysis shows to be the most critical.

4.8.7 The demonstration shall be carried out in controlled conditions in the following manner in compliance with the evacuation plan.

- .1 The demonstration shall commence with the craft afloat in harbour, in reasonably calm conditions, with all machinery and equipment operating in the normal seagoing condition.
- .2 All exits and doors inside the craft shall be in the same position as they are under normal seagoing condition.
- .3 Safety belts, if required, shall be fastened.
- .4 The evacuation routes for all passengers and crew shall be such that no person need enter the water during the evacuation.

4.8.8 For passenger craft, a representative composition of persons with normal health, height and weight shall be used in the demonstration, and shall consist of different sexes and ages so far as it is practicable and reasonable.

4.8.9 The persons, other than the crew selected for the demonstration, shall not have been specially drilled for such a demonstration.

4.8.10 Where the Administration is satisfied that the evacuation time²³ determined in accordance with 4.8.1 to 4.8.9 can thereby be accurately estimated, the Administration may accept an evacuation demonstration in which persons are not required to descend through MES or equivalent means of evacuation, provided the time required to embark into the survival craft can be determined using:

- .1 data obtained from the type-approval tests of the equipment, increased by a factor based on the guidelines developed by the Organization; or
- .2 time extrapolated from trials using a limited number of participants.

²³ Refer to the Guidelines for a simplified evacuation analysis of high-speed passenger craft (MSC/Circ.1166), in particular paragraph 3.5.1 thereof.

4.8.11 An emergency evacuation demonstration shall be carried out for all new designs of high-speed craft and for other craft where evacuation arrangements differ substantially from those previously tested.

4.8.12 The specific evacuation procedure followed during the craft's initial demonstration on which certification is based shall be included in the craft operating manual together with the other evacuation procedures contained in 4.8.2. During the demonstration, video recordings shall be made, both inside and outside the craft, which shall form an integral part of the training manual required by 18.2.

4.9 Baggage, stores, shops and cargo compartments

4.9.1 Provision shall be made to prevent shifting of baggage, stores and cargo compartment contents, having due regard to occupied compartments and accelerations likely to arise. If safeguarding by positioning is not practicable, adequate means of restraint for baggage, stores and cargo shall be provided. Shelves and overhead shelves for storage of carry-on baggage in public spaces shall be provided with adequate means to prevent the luggage from falling out in any conditions that may occur.

4.9.2 Controls, electric equipment, high-temperature parts, pipelines or other items, the damage or failure of which could affect the safe operation of the craft or which may require access by crew members during a voyage, shall not be located in baggage, store and cargo compartments unless such items are adequately protected so that they cannot be damaged or, where applicable, operated inadvertently by loading, by unloading or by movement of the contents of the compartment.

4.9.3 Loading limits, if necessary, shall be durably marked in those compartments.

4.9.4 Having regard to the purpose of the craft, the closures of the exterior openings of the luggage and cargo compartments as well as special-category spaces shall be appropriately weathertight.

4.10 Noise levels

4.10.1 The noise level in public spaces and crew accommodation shall be kept as low as possible to enable the public address system to be heard, and shall not in general exceed 75 dB(A).

4.10.2 The maximum noise level in the operating compartment shall not in general exceed 65 dB(A) to facilitate communication within the compartment and external radiocommunications.

4.11 Protection of the crew and passengers

4.11.1 Efficient guard rails or bulwarks shall be fitted on all exposed parts of decks to which crew or passengers have access. Alternative arrangements such as safety harnesses and jack-stays may be accepted if they provide an equivalent level of safety. The height of the bulwarks or guard rails shall be at least 1 m from the deck, provided that where this height would interfere with the normal operation of the craft, a lesser height may be approved.

4.11.2 The opening below the lowest course of the guard rails shall not exceed 230 mm. The other courses shall be not more than 380 mm apart. In the case of craft with rounded gunwales the guard rail supports shall be placed on the flat of the deck.

4.11.3 Satisfactory means (in the form of guard rails, life lines, gangways or underdeck passages, etc.) shall be provided for the protection of the crew in getting to and from their quarters, the machinery space and all other parts used in the necessary work of the craft.

4.11.4 Deck cargo carried on any craft shall be so stowed that any opening which is in way of the cargo and which gives access to and from the crew's quarters, the machinery space and all other parts used in the necessary work of the craft, can be properly closed and secured against the admission of water. Effective protection for the crew in the form of guard rails or life lines shall be provided above the deck cargo if there is no convenient passage on or below the deck of the craft.

CHAPTER 5

Directional Control Systems

5.1 General

5.1.1 Craft shall be provided with means for directional control of adequate strength and suitable design to enable the craft's heading and direction of travel to be effectively controlled to the maximum extent possible in the prevailing conditions and craft speed without undue physical effort at all speeds and in all conditions for which the craft is to be certificated. The performance shall be verified in accordance with annex 9.

5.1.2 Directional control may be achieved by means of air or water rudders, foils, flaps, steerable propellers or jets, yaw control ports or side thrusters, differential propulsive thrust, variable geometry of the craft or its lift-system components or by a combination of these devices.

5.1.3 For the purpose of this chapter, a directional control system includes any steering device or devices, any mechanical linkages and all power or manual devices, controls and actuating systems.

5.1.4 Attention is drawn to the possibility of interaction between directional control systems and stabilisation systems. Where such interaction occurs or where dual-purpose components are fitted, the requirements of 12.5 and chapters 16 and 17 are also to be complied with, as applicable.

5.2 Reliability

5.2.1 The probability of total failure of all directional control systems shall be extremely remote when the craft is operating normally, i.e., excluding emergency situations such as grounding, collision or a major fire.

5.2.2 A design incorporating a power drive or an actuation system employing powered components for normal directional control shall provide a secondary means of actuating the device unless an alternative system is provided.

5.2.3 The secondary means of actuating the directional control device may be manually driven when the Administration is satisfied that this is adequate, bearing in mind the craft's size and design and any limitations of speed or other parameters that may be necessary.

5.2.4 The directional control systems shall be constructed so that a single failure in one drive or system, as appropriate, will not render any other one inoperable or unable to bring the craft to a safe situation. The Administration may allow a short period of time to permit the connection of

a secondary control device when the design of the craft is such that such delay will not, in their opinion, hazard the craft.

5.2.5 A failure mode and effect analysis shall include the directional control system.

5.2.6 If necessary to bring the craft to a safe condition, power drives for directional control devices, including those required to direct thrust forward or astern, shall become operative automatically, and respond correctly, within 5 s of power or other failure. Back-up electrical systems may be required for the starting-up time of an auxiliary diesel according to 12.2 or an emergency diesel generator according to 12.3.6.

5.2.7 Directional control devices involving variable geometry of the craft or its lift system components shall, so far as is practicable, be so constructed that any failure of the drive linkage or actuating system will not significantly hazard the craft.

5.3 Demonstrations

5.3.1 The limits of safe use of any of the control system devices, shall be based on demonstrations and a verification process in accordance with annex 9.

5.3.2 Demonstration in accordance with annex 9 shall determine any adverse effects upon safe operation of the craft in the event of an uncontrollable total deflection of any one control device. Any limitation on the operation of the craft as may be necessary to ensure that the redundancy or safeguards in the systems provide equivalent safety shall be included in the craft operating manual.

5.4 Control position

5.4.1 All directional control systems shall normally be operated from the craft's operating station.

5.4.2 If directional control systems can also be operated from other positions, then two-way communication shall be arranged between the operating station and these other positions.

5.4.3 Adequate indications shall be provided at the operating station and these other positions to provide the person controlling the craft with verification of the correct response of the directional control device to this demand, and also to indicate any abnormal responses or malfunction. The indications of steering response or rudder angle indicator shall be independent of the system for directional control. The logic of such feedback and indications shall be consistent with the other alarms and indications so that in an emergency operators are unlikely to be confused.

CHAPTER 6

Anchoring, Towing and Berthing

6.1 General

6.1.1 A primary assumption made in this chapter is that high-speed craft will only need an anchor for emergency purposes.

6.1.2 The arrangements for anchoring, towing and berthing and the local craft structure, the design of the anchor, towing and berthing arrangements and the local craft structure shall be such that risks to persons carrying out anchoring, towing or berthing procedures are kept to a minimum.

6.1.3 All anchoring equipment, towing bits, mooring bollards, fairleads, cleats and eyebolts shall be so constructed and attached to the hull that, in use up to design loads, the watertight integrity of the craft will not be impaired. Design loads and any directional limitations assumed shall be listed in the craft operating manual.

6.1.4 Under any operating load up to the breaking strength of the anchor cable or mooring lines, the loads on the bits, bollards, etc., shall not result in damage to the hull structure that will impair its watertight integrity. A strength margin of at least 20% above the resultant load based on the minimum specified breaking strength of the relevant cable or warp shall be required.

6.2 Anchoring

6.2.1 High-speed craft shall be provided with at least one anchor with its associated cable or cable and warp and means of recovery. Every craft shall be provided with adequate and safe means for releasing the anchor and its cable and warp.

6.2.2 Good engineering practice shall be followed in the design of any enclosed space containing the anchor-recovery equipment to ensure that persons using the equipment are not put at risk. Particular care shall be taken with the means of access to such spaces, the walkways, the illumination and protection from the cable and the recovery machinery.

6.2.3 Adequate arrangements shall be provided for two-way voice communication between the operating compartment and persons engaged in dropping, weighing or releasing the anchor.

6.2.4 The anchoring arrangements shall be such that any surfaces against which the cable may chafe (for example, hawse pipes and hull obstructions) are designed to prevent the cable from being damaged and fouled. Adequate

arrangements shall be provided to secure the anchor under all operational conditions.

6.2.5 The craft shall be protected so as to minimize the possibility of the anchor and cable damaging the structure during normal operation.

6.3 Towing

6.3.1 Adequate arrangements shall be provided to enable the craft to be towed in the worst intended conditions. Where towage is to be from more than one point, a suitable bridle shall be provided.

6.3.2 The towing arrangements shall be such that any surface against which the towing cable may chafe (for example, fairleads) is of sufficient radius to prevent the cable being damaged when under load.

6.3.3 The maximum permissible speed at which the craft may be towed shall be included in the operating manual.

6.4 Berthing

6.4.1 Where necessary, suitable fairleads, bitts and mooring ropes shall be provided.

6.4.2 Adequate storage space for mooring lines shall be provided such that they are readily available and secured against the high relative wind speeds and accelerations which may be experienced.

CHAPTER 7

Fire Safety

PART A - GENERAL

7.1 General Requirements

7.1.1 The following basic principles underlie the provisions in this chapter and are embodied therein as appropriate, having regard to the category of craft and the potential fire hazard involved:

- .1 maintenance of the main functions and safety systems of the craft, including propulsion and control, fire-detection, alarms and extinguishing capability of unaffected spaces, after fire in any one compartment on board;
- .2 division of the public spaces for category B craft, in such a way that the occupants of any compartment can escape to an alternative safe area or compartment in case of fire;
- .3 subdivision of the craft by fire-resisting boundaries;
- .4 restricted use of combustible materials and materials generating smoke and toxic gases in a fire;
- .5 detection, containment and extinction of any fire in the space of origin;
- .6 protection of means of escape and access for fire fighting; and
- .7 immediate availability of fire-extinguishing appliances.

7.1.2 The requirements in this chapter are based in the following conditions:

- .1 Where a fire is detected, the crew immediately puts into action the fire-fighting procedures, informs the base port of the accident and prepares for the escape of passengers to alternative safe area or compartment, or, if necessary, for the evacuation of passengers.
- .2 The use of fuel with a flashpoint below 43°C is not recommended. However, fuel with a lower flashpoint, but not lower than 35°C, may be used in gas turbines only subject to compliance with the provisions specified in 7.5.1 to 7.5.6.
- .3 The repair and maintenance of the craft is carried out in accordance with the requirements given in chapters 18 and 19 of this Code.

- .4 Enclosed spaces having reduced lighting, such as cinemas, discothèques, and similar spaces are not permitted.
- .5 Passenger access to special category spaces and open ro-ro spaces is prohibited during the voyage except when accompanied by a crew member responsible for fire safety. Only authorised crew members shall be permitted to enter cargo spaces at sea.

7.2 Definitions

7.2.1 "Fire-resisting divisions" are those divisions formed by bulkheads and decks which comply with the following:

- .1 They shall be constructed of non-combustible or fire-restricting materials which by insulation or inherent fire-resisting properties satisfy the requirements of 7.2.1.2 to 7.2.1.6.
- .2 They shall be suitably stiffened.
- .3 They shall be so constructed as to be capable of preventing the passage of smoke and flame up to the end of the appropriate fire protection time.
- .4 Where required they shall maintain load-carrying capabilities up to the end of the appropriate fire protection time.
- .5 They shall have thermal properties such that the average temperature on the unexposed side will not rise more than 140°C above the original temperature, nor will the temperature, at any one point, including any joint, rise more than 180°C above the original temperature during the appropriate fire protection time.
- .6 A test of a prototype bulkhead or deck in accordance with the Fire Test Procedures Code shall be required to ensure that it meets the above requirements.

7.2.2 "Fire-restricting materials" are those materials which have properties complying with the Fire Test Procedures Code.

7.2.3 "Non-combustible material" is a material which neither burns nor gives off flammable vapours in sufficient quantity for self-ignition when heated to approximately 750°C, this being determined in accordance with the Fire Test Procedures Code.

7.2.4 "A standard fire test" is one in which specimens of the relevant bulkheads, decks or other constructions are exposed in a test furnace by a specified test method in accordance with the Fire Test Procedures Code.

7.2.5 Where the words "steel or other equivalent material" occur, "equivalent material" means any non-combustible material which, by itself or due to insulation provided, has structural and integrity properties equivalent to steel at the end of the applicable exposure to the standard fire test (e.g., aluminium alloy with appropriate insulation).

7.2.6 "Low flame-spread" means that the surface thus described will adequately restrict the spread of flame, this being determined in accordance with the Fire Test Procedures Code.

7.2.7 "Smoke-tight" or "capable of preventing the passage of smoke" means that a division made of non-combustible or fire-restricting materials is capable of preventing the passage of smoke.

7.3 Classification of space use

7.3.1 For the purposes of classification of space use in accordance with fire hazard risks, the following grouping shall apply:

- .1 "Areas of major fire hazard", referred to in tables 7.4-1 and 7.4-2 by A, include the following spaces:
 - machinery spaces
 - ro-ro spaces
 - spaces containing dangerous goods
 - special category spaces
 - store-rooms containing flammable liquids
 - galleys
 - sales shops having a deck area of 50 m² or greater and containing flammable liquids for sale
 - trunks in direct communication with the above spaces.

- .2 "Areas of moderate fire hazard", referred to in tables 7.4-1 and 7.4-2 by B, include the following spaces:
 - auxiliary machinery spaces, as defined in 1.4.5
 - bond stores containing packaged beverages with alcohol content not exceeding 24% by volume
 - crew accommodation containing sleeping berths
 - service spaces
 - sales shops having a deck area of less than 50 m² containing a limited amount of flammable liquids for sale and where no dedicated store is provided separately
 - sales shops having a deck area of 50 m² or greater not containing flammable liquids

- trunks in direct communication with the above spaces.
- .3 "Areas of minor fire hazard", referred to in tables 7.4-1 and 7.4-2 by C, include the following spaces:
 - auxiliary machinery spaces, as defined in 1.4.6
 - cargo spaces
 - fuel tank compartments
 - public spaces
 - tanks, voids and areas of little or no fire risk
 - refreshment kiosks
 - sales shops other than those specified in 7.3.1.1 and 7.3.1.2
 - corridors in passenger areas and stairway enclosures
 - crew accommodation other than that mentioned in 7.3.1.2
 - trunks in direct communication with the above spaces.
- .4 "Control stations", referred to in tables 7.4-1 and 7.4-2 by D, as defined in 1.4.16
- .5 "Evacuation Stations and external escape routes", referred to in tables 7.4-1 and 7.4-2 by E, include the following areas:
 - external stairs and open decks used for escape routes
 - assembly stations, internal and external
 - open deck spaces and enclosed promenades forming lifeboat and liferaft embarkation and lowering stations
 - the craft's side to the waterline in the lightest seagoing condition, superstructure and deckhouse sides situated below and adjacent to the liferaft's and evacuation slide's embarkation areas.
- .6 "Open Spaces" referred to in tables 7.4-1 and 7.4-2 by F, include the following areas:
 - open spaces locations other than evacuation stations and external escape routes and control stations.

7.3.2 In relation to the classification of spaces in 7.3.1, the following additional criteria shall be applied:

- .1 If a space is divided by partial bulkheads into two (or more) smaller areas such that they form enclosed spaces, then the enclosed spaces shall be surrounded by bulkheads and decks in accordance with tables 7.4-1

and 7.4-2, as applicable. However, if the separating bulkheads of such spaces are at least 30% open, then the spaces may be considered as the same space.

- .2 Cabinets having a deck area of less than 2 m² may be accepted as part of the space they serve, provided they have open ventilation to the space and do not contain any material or equipment that could be a fire risk.
- .3 Where a space has the special characteristics of two or more space groupings, the structural fire protection time of the divisions shall be the highest for the space groupings concerned. For example, the structural fire protection time of the divisions of emergency generator rooms shall be of the highest value for the space when the space is considered as being a control station (D) and a machinery space (A).”

7.3.3 In approving structural fire protection details, the Administration shall have regard to the risk of heat transmission at intersections and terminal points of required thermal barriers.

7.3.4 To prevent heat transmission at intersections and terminal points, the insulation of the deck or bulkhead shall be carried past the intersection or terminal point for a distance of at least 450 mm in the case of steel or aluminium structures (refer to figures 7.3.4a and 7.3.4b).

7.3.5 If a space is divided by a deck or bulkhead and the fire insulation required for each space is different, the insulation with the higher structural fire protection time shall continue on the deck or bulkhead with the insulation of the lesser structural fire protection time for a distance of at least 450 mm beyond the boundary between the spaces.

7.3.6 Where the lower part of the fire insulation has to be cut for drainage, the construction shall be in accordance with the structural details shown in figure 7.3.6.

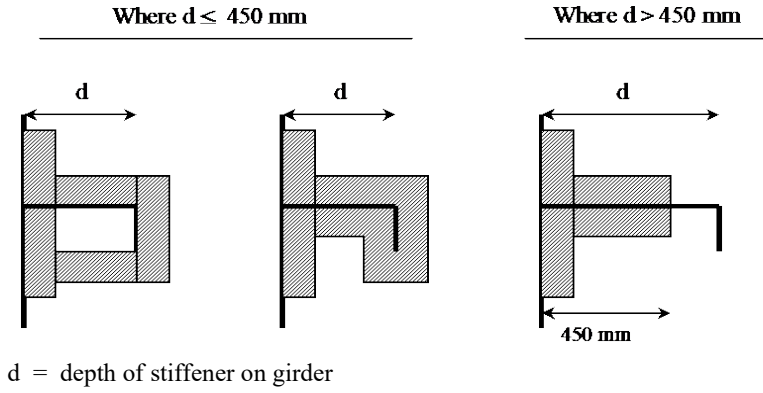

Figure 7.3.4a

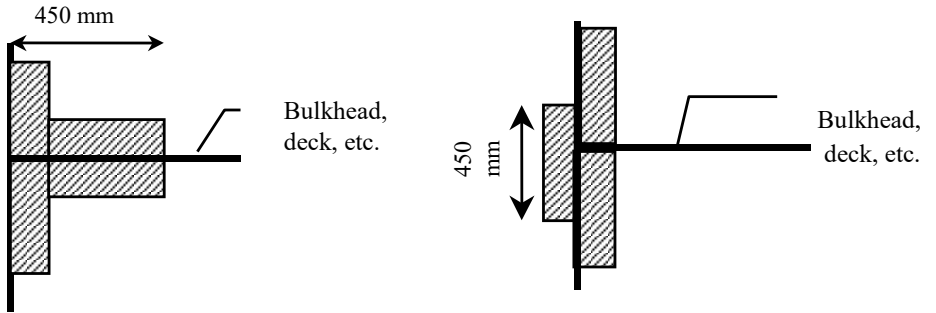

Figure 7.3.4b

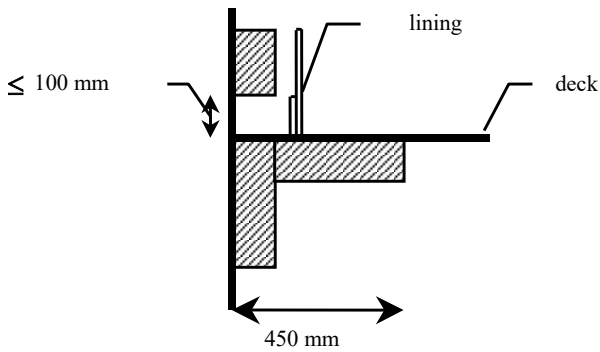

Figure 7.3.6

7.4 Structural fire protection

7.4.1 Main structure

7.4.1.1 The requirements below apply to all craft irrespective of construction material. The structural fire protection times for separating bulkheads and decks shall be in accordance with tables 7.4-1 and 7.4-2, and the structural fire protection times are all based on providing protection for a period of 60 min as referred to in 4.8.1. If any other lesser structural fire protection time is determined for category A craft and cargo craft by 4.8.1, then the times given below in 7.4.2.2 and 7.4.2.3 may be amended pro rata. In no case shall the structural fire protection time be less than 30 min.

7.4.1.2 In using tables 7.4-1 and 7.4-2, it shall be noted that the title of each category is intended to be typical rather than restricted. For determining the appropriate fire integrity standards to be applied to boundaries between adjacent spaces, where there is doubt as to their classification for the purpose of this section, they shall be treated as spaces within the relevant category having the most stringent boundary requirement.

7.4.1.3 The hull, superstructure, structural bulkheads, decks, deckhouses and pillars shall be constructed of approved non-combustible materials having adequate structural properties. The use of other fire-restricting materials may be permitted provided the requirements of this chapter are complied with and the materials are in compliance with the Fire Test Procedures Code.

7.4.1.4 Paragraph 7.4.1.3 does not apply to appendages such as air propellers, air ducts to propellers, transmission shafts, rudders and other control surfaces, struts, spars, flexible skirts, etc., which do not comprise part of the main structure of the craft.

Table 7.4-1

Structural fire protection times for separating bulkheads and decks of passenger craft

	A	B	C	D	E	F
Areas of major fire hazard A	60 _{1,2}	60 _{1,2} / 30 ₁	60 _{1,8} / 30 ₃	60 ₁ / 30 _{3,4}	60 ₁ / 30 ₃	60 _{1,7,9} / -
Areas of moderate fire hazard B		30 ₂	30 ₈ / 30 ₃	60 _{3,4} / 30 ₃	30 ₃	- / 30 ₃
Areas of minor fire hazard C			30 ₃	30 _{8,10} / 30 _{3,4}	30 ₃	- / 30 ₃
Control stations D				30 _{3,4}	30 ₃	30 ₃
Evacuation stations and escape routes E					30 ₃	30 ₃
Open spaces F						-

NOTES:

The figures on either side of the diagonal line represent the required structural fire protection time for the protection system on the relevant side of the division. When steel construction is used and two different structural fire protection times are required for a division in the table, only the greater one need be applied.

- 1 The upper side of decks within spaces protected by fixed fire-extinguishing systems need not be insulated.
- 2 Where adjacent spaces are in the same alphabetical category and a note 2 appears, a bulkhead or deck between such spaces need not be fitted if deemed unnecessary by the Administration. For example, a bulkhead need not be required between two store-rooms. A bulkhead, is however, required between a machinery space and a special category space even through both spaces are in the same category.
- 3 No structural fire protection requirements; however, a smoke-tight division made of non-combustible or fire restricting material is required.
- 4 Control stations which are also auxiliary machinery spaces shall be provided with 30 min structural fire protection.

Table 7.4-2

Structural fire protection times for separating bulkheads and decks of cargo craft

	A	B	C	D	E	F
Areas of major fire hazard A	60 1,2	30 1	3 1,8	3 1	3 1	- 1,7,9
Areas of moderate fire hazard B		2,6 6	3 3	3 3,4	3 3	- 3
Areas of minor fire hazard C			3 8	3 3,4	3 3	- 3
Control stations D				3,4 3,4	3 3,4	- 3
Evacuation stations and escape routes E					3 3	- 3
Open spaces F						-

- 5 There are no special requirements for material or integrity of boundaries where only a dash appears in the tables.
- 6 The fire protection time is 0 min and the time for prevention of passage of smoke and flame is 30 min as determined by the first 30 min of the standard fire test.
- 7 Fire resisting divisions need not comply with 7.2.1.5.
- 8 When steel construction is used, fire resisting divisions adjacent to void spaces need not comply with 7.2.1.5.
- 9 The fire protection time may be reduced to 0 min for those parts of open ro-ro spaces which are not essential parts of the craft's main load bearing structure, where passengers have no access to them and the crew need not have access to them during any emergency.
- 10 On category A craft, this value may be reduced to 0 min where the craft is provided with only a single public space (excluding lavatories) protected by a sprinkler system and adjacent to the operating compartment.

7.4.2 Fire-resisting divisions

7.4.2.1 Areas of major and moderate fire hazard shall be enclosed by fire-resisting divisions complying with the requirements of 7.2.1 except where the omission of any such division would not affect the safety of the craft. These requirements need not apply to those parts of the structure in contact with water at least 300 mm below the craft's waterline in the lightweight condition in displacement mode, but due regard shall be given to the effect of temperature of hull in contact with water and heat transfer from any uninsulated structure in contact with water to insulated structure above the water.

7.4.2.2 Fire-resisting bulkheads and decks shall be constructed to resist exposure to the standard fire test for a period of 30 min for areas of moderate fire hazard and 60 minutes for areas of major fire hazard except as provided in 7.4.1.1.

7.4.2.3 Main load-carrying structures within areas of major fire hazard and areas of moderate fire hazard and structures supporting control stations shall be arranged to distribute load such that there will be no collapse of the construction of the hull and superstructure when it is exposed to fire for the appropriate fire protection time. The load-carrying structure shall also comply with the requirements of 7.4.2.4 and 7.4.2.5.

7.4.2.4 If the structures specified in 7.4.2.3 are made of aluminium alloy their installation shall be such that the temperature of the core does not rise more than 200°C above the ambient temperature in accordance with the times in 7.4.1.1 and 7.4.2.2.

7.4.2.5 If the structures specified in 7.4.2.3 are made of combustible material, their insulation shall be such that their temperatures will not rise to a level where deterioration of the construction will occur during the exposure to the standard fire test in accordance with the Fire Test Procedures Code to such an extent that the load-carrying capability, in accordance with the times in 7.4.1.1 and 7.4.2.3, will be impaired.

7.4.2.6 The construction of all doors, and door frames in fire-resisting divisions, with the means of securing them when closed, shall provide resistance to fire as well as to the passage of smoke and flame equivalent to that of the bulkheads in which they are situated. Watertight doors of steel need not be insulated. Also, where a fire-resisting division is penetrated by pipes, ducts, electrical cables etc., arrangements shall be made to ensure that the fire-resisting integrity of the division is not impaired, and necessary testing shall be carried out in accordance with the Fire Test Procedures Code. Where machinery shafts penetrate fire-resisting watertight divisions, arrangements shall be made to ensure that the required watertight and fire-resisting integrity of the division is not impaired.

7.4.2.7 Ventilation openings may be accepted in entrance doors to public toilets, provided they are positioned in the lower portion of the door and

fitted with closable grilles made of non-combustible or fire-restricting material and operable from outside the space.

7.4.3 Restricted use of combustible materials

7.4.3.1 All separating divisions, ceilings or linings if not a fire resisting division, shall be of non-combustible or fire restricting materials. Draught stops shall be of non-combustible or fire-restricting material.

7.4.3.2 Where insulation is installed in areas in which it could come into contact with any flammable fluids or their vapours, its surface shall be impermeable to such flammable fluids or vapours. The fire insulation in such spaces may be covered by metal sheets (not perforated) or by vapour proof glass cloth sealed at joints.

7.4.3.3 Furniture and furnishings in public spaces and crew accommodation shall comply with the following standards²⁴:

- .1 all case furniture e.g., desks, wardrobes, dressing tables, bureaux and dressers is constructed entirely of approved non-combustible or fire-restricting materials, except that a combustible veneer with a calorific value not exceeding 45 MJ/m² may be used on the exposed surface of such articles;
- .2 all other furniture such as chairs, sofas and tables, is constructed with frames of non-combustible or fire-restricting materials;
- .3 all draperies, curtains and other suspended textile materials have qualities of resistance to the propagation of flame, this being determined in accordance with the Fire Test Procedures Code;
- .4 all upholstered furniture has qualities of resistance to the ignition and propagation of flame, this being determined in accordance with the Fire Test Procedures Code;
- .5 all bedding components have qualities of resistance to the ignition and propagation of flame, this being determined in accordance with the Fire Test Procedures Code; and

²⁴ Fire test procedures referenced in the FTP Code (resolution MSC.61(67)), as amended, and MSC/Circ.916, 964, 1004, 1008, 1036 and 1120 should be applied to items and materials covered by this paragraph as follows:

- .1 case furniture (FTP Code, annex 1, parts 1 and 10);
- .2 frames of all other furniture (FTP Code, annex 1, parts 1 and 10);
- .3 draperies, textiles and other suspended textile materials (FTP Code, annex 1, part 7);
- .4 upholstered furniture, e.g. passenger seating (FTP Code, annex 1, part 8);
- .5 bedding components (FTP Code, annex 1, part 9); and
- .6 deck finish materials (FTP Code, annex 1, parts 2 and 6).

- .6 all deck finish materials comply with the Fire Test Procedures Code.
(TSFS 2023:58)

7.4.3.4 Subject to 7.4.3.5 the following surfaces shall, as a minimum standard, be constructed of materials having low flame-spread characteristics:

- .1 exposed surfaces in corridors and stairway enclosures, and of bulkheads (including windows), wall and ceiling linings in all public spaces, crew accommodation, service spaces, control stations and internal assembly and evacuation stations;
- .2 surfaces in concealed or inaccessible spaces in corridors and stairway enclosures, public spaces, crew accommodation, service spaces, control stations and internal assembly and evacuation stations.

7.4.3.5 Paragraph 7.4.3.4 does not apply to partitions, windows and sidescuttles made of glass which are deemed to be non-combustible and to comply with the requirements for low-flame spread surfaces or to items and materials referred to in 7.4.3.3²⁵.

7.4.3.6 Any thermal and acoustic insulation shall be of non-combustible or of fire-restricting material. Vapour barriers and adhesives used in conjunction with insulation, as well as insulation of pipe fittings for cold service systems need not be non-combustible or fire-restricting, but they shall be kept to the minimum quantity practicable and their exposed surfaces shall have low flame spread characteristics.

7.4.3.7 Exposed surfaces in corridors and stairway enclosures, and of bulkheads (including windows), wall and ceiling linings, in all public spaces, crew accommodation, service spaces, control stations and internal assembly and evacuation stations shall be constructed of materials which, when exposed to fire, are not capable of producing excessive quantities of smoke or toxic products, this being determined in accordance with the Fire Test Procedures Code.

7.4.3.8 Void compartments, where low-density combustible materials are used to provide buoyancy, shall be protected from adjacent fire hazard areas by fire-resisting divisions, in accordance with tables 7.4-1 and 7.4-2. Also, the space and closures to it shall be gastight but it shall be ventilated to atmosphere.

7.4.3.9 In compartments where smoking is allowed, suitable non-combustible ash containers shall be provided. In compartments where smoking is not allowed, adequate notices shall be displayed.

²⁵ Refer to paragraph 7.9.3.4 and the FTP Code, annex 2, paragraphs 1 and 5.1.

7.4.3.10 The exhaust gas pipes shall be arranged so that the risk of fire is kept to a minimum. To this effect, the exhaust system shall be insulated and all compartments and structures which are contiguous with the exhaust system, or those which may be affected by increased temperatures caused by waste gases in normal operation or in an emergency, shall be constructed of non-combustible material or be shielded and insulated with non-combustible material to protect from high temperatures.

7.4.3.11 The design and arrangement of the exhaust manifolds or pipes shall be such as to ensure the safe discharge of exhaust gases.

7.4.4 Arrangement

7.4.4.1 Internal stairways connecting only two decks need only be enclosed at one deck by means of divisions and self-closing doors having the structural fire protection time as required by tables 7.4-1 and 7.4-2 for divisions separating those areas which each stairway serves

7.4.4.2 Open stairways may be fitted in public spaces consisting of only two decks, provided the stairways lie wholly within such public spaces and the following conditions are met:

- .1 all levels are used for the same purpose;
- .2 the area of the opening between the lower and upper parts of the space is at least 10% of the deck area between the upper and lower parts of the space;
- .3 the design is such that persons within the space should be generally aware, or could easily be made aware of, a developing fire or other hazardous situation located within that space;
- .4 sufficient means of escape are provided from both levels of the space directly leading to an adjacent safe area or compartment; and
- .5 the whole space is served by one section of the sprinkler system.

7.4.4.3 Lift trunks shall be so fitted as to prevent the passage of smoke and flame from one deck to another and shall be provided with means of closing so as to permit the control of draught and smoke.

7.4.4.4 In public spaces, crew accommodation, service spaces, control stations, corridors and stairways, air spaces enclosed behind ceilings, panelling or linings shall be suitably divided by close-fitting draught stops not more than 14 m apart. Draught stops are not required in public spaces of category A craft having only one public space and on other craft in spaces with open ceilings (perforated ceilings) where the opening is 40% or more

and the ceiling is arranged in such a way that a fire behind the ceiling can be easily seen and extinguished.

7.5 Fuel and other flammable fluid tanks and systems

7.5.1 Tanks containing fuel and other flammable fluids shall be separated from passenger, crew, and baggage compartments by vapour-proof enclosures or cofferdams which are suitably ventilated and drained.

7.5.2 Fuel oil tanks shall not be located in, be formed by any part of the structural boundary of, areas of major fire hazard. However, flammable fluids of a flashpoint not less than 60°C may be located within such areas provided the tanks are made of steel or other equivalent material. The use of aluminium in lubricating oil sump tanks for engines, or in lubricating oil filter housings fitted integral with the engines, is accepted.

7.5.3 Every fuel oil pipe which, if damaged, would allow oil to escape from a storage, settling or daily service tank shall be fitted with a cock or valve directly on the tank capable of being closed from a position outside the space concerned in the event of a fire occurring in the space in which such tanks are situated.

7.5.4 Pipes, valves and couplings conveying flammable fluids shall be of steel or such alternative material satisfactory to a standard²⁶, in respect of strength and fire integrity having regard to the service pressure and the spaces in which they are installed. Wherever practicable, the use of flexible pipes shall be avoided.

7.5.5 Pipes, valves and couplings conveying flammable fluids shall be arranged as far from hot surfaces or air intakes of engine installations, electrical appliances and other potential sources of ignition as is practicable and be located or shielded so that the likelihood of fluid leakage coming into contact with such sources of ignition is kept to a minimum.

7.5.6 Fuel with a flash point below 35° shall not be used. In every craft in which fuel with a flashpoint below 43°C is used, the arrangements for the storage, distribution and utilization of the fuel shall be such that, having regard to the hazard of fire and explosion which the use of such fuel may entail, the safety of the craft and of persons on board is preserved. The arrangements shall comply, in addition to the requirements of 7.5.1 to 7.5.5, with the following provisions:

- .1 tanks for the storage of such fuel shall be located outside any machinery space and at a distance of not less than

²⁶ Refer to the Guidelines for the Application of Plastic Pipes on Ships, adopted by the Organization by resolution A.753(18).

- 760 mm inboard from the shell side and bottom plating, and from decks and bulkheads;
- .2 arrangements shall be made to prevent overpressure in any fuel tank or in any part of the oil fuel system, including the filling pipes. Any relief valves and air or overflow pipes shall discharge to a position which, in the opinion of the Administration, is safe;
 - .3 the spaces in which fuel tanks are located shall be mechanically ventilated, using exhaust fans providing not less than six air changes per hour. The fans shall be such as to avoid the possibility of ignition of flammable gas-air mixtures. Suitable wire mesh guards shall be fitted over inlet and outlet ventilation openings. The outlets for such exhausts shall discharge to a position which, in the opinion of the Administration is safe. 'No Smoking' signs shall be posted at the entrance to such spaces;
 - .4 earthed electrical distribution systems shall not be used, with the exception of earthed intrinsically safe circuits;
 - .5 suitable certified safe type²⁷ electrical equipment be used in all spaces where fuel leakage could occur, including the ventilation system. Only electrical equipment and fittings essential for operational purposes shall be fitted in such spaces;
 - .6 a fixed vapour-detection system shall be installed in each space through which fuel lines pass, with alarms provided at the continuously manned control station;
 - .7 every fuel tanks shall, where necessary, be provided with "savealls" or gutters which would catch any fuel which may leak from such tank;
 - .8 safe and efficient means of ascertaining the amount of fuel contained in any tank shall be provided. Sounding pipes shall not terminate in any space where the risk of ignition of spillage from the sounding pipe might arise. In particular, they shall not terminate in passenger or crew spaces. The use of cylindrical gauge glasses is prohibited, except for cargo craft where the use of oil-level gauges with flat glasses and self-closing valves between the gauges and fuel tanks may be permitted by the Administration. Other means of ascertaining the amount

²⁷ Refer to the Recommendations published by the International Electrotechnical Commission and, in particular, publication 60092 - Electrical Installations in Ships.

of fuel contained in any tank may be permitted if such means do not require penetration below the top of the tank, and providing their failure or overfilling of the tank will not permit the release of fuel;

- .9 during bunkering operations, no passenger shall be on board the craft or in the vicinity of the bunkering station, and adequate 'No Smoking' and 'No Naked Lights' signs shall be posted. Vessel-to-shore fuel connections shall be of closed type and suitably grounded during bunkering operations;
- .10 the provision of fire detection and extinguishing systems in spaces where non-integral fuel tanks are located shall be in accordance with requirements of 7.7.1 to 7.7.3; and
- .11 refuelling of the craft shall be done at the approved refuelling facilities, detailed in the route operational manual, at which the following fire appliances are provided:
 - .11.1 a suitable foam applicator system consisting of monitors and foam-making branch pipes capable of delivering foam solution at a rate of not less than 500 l/m for not less than 10 min;
 - .11.2 dry powder extinguishers of total capacity not less than 50 kg; and
 - .11.3 carbon dioxide extinguishers of total capacity not less than 16 kg.

7.6 Ventilation

7.6.1 The main inlets and outlets of all ventilation systems shall be capable of being closed from outside the spaces being ventilated. The controls shall be easily accessible as well as prominently and permanently marked and shall indicate whether the shut-off is open or closed. In addition, such openings to areas of major fire hazard shall be capable of being closed from a continuously manned control station.

7.6.2 All ventilation fans shall be capable of being stopped from outside the spaces which they serve, and from outside the spaces in which they are installed. Ventilation fans serving areas of major fire hazard shall be capable of being operated from a continuously manned control station. The means provided for stopping the power ventilation to the machinery space shall be separated from the means provided for stopping ventilation of other spaces.

7.6.3 Areas of major fire hazard and spaces serving as assembly stations shall have independent ventilation systems and ventilation ducts. Ventilation

ducts for areas of major fire hazard shall not pass through other spaces, unless they are contained within a trunk or in an extended machinery space or casing insulated in accordance with tables 7.4-1 and 7.4-2; ventilation ducts of other spaces shall not pass through areas of major fire hazard. Ventilation outlets from areas of major fire hazard shall not terminate within a distance of 1 m from any control station, evacuation station or external escape route. In addition, exhaust ducts from galley ranges shall be fitted with:

- .1 a grease trap readily removable for cleaning unless an alternative approved grease removal system is fitted;
- .2 a fire damper located in the lower end of the duct (the junction between the duct and the galley range hood) which is automatically and remotely operated, and in addition a remotely operated fire damper located in the upper end of the duct,;
- .3 a fixed means for extinguishing a fire within the duct;
- .4 remote control arrangements for shutting off the exhaust fans and supply fans, for operating the fire dampers mentioned in .2 and for operating the fire-extinguishing system, which shall be placed in a position close to the entrance to the galley. Where a multi-branch system is installed, a remote means located with the above controls shall be provided to close all branches exhausting through the same main duct before an extinguishing medium is released into the system; and
- .5 suitably located hatches for inspection and cleaning. At minimum, one hatch shall be provided close to the exhaust fan and others located in areas of high grease accumulation such as the lower end of the duct as referred to in 7.6.3.2.

7.6.4 Where a ventilation duct passes through a fire-resisting division, a fail safe automatic closing fire damper shall be fitted adjacent to the division. The duct between the division and the damper shall be of steel or other equivalent material and insulated to the same standard as required for the fire resisting division. The fire damper may be omitted where ducts pass through spaces surrounded by fire-resisting divisions without serving those spaces providing that the duct has the same structural fire protection time as the divisions it penetrates. Where a ventilation duct passes through a smoke-tight division, a smoke damper shall be fitted at the penetration unless the duct which passes through the space does not serve that space. Fire and smoke dampers shall be arranged so as to be readily accessible. Where placed behind ceilings or linings, they shall be provided with an inspection door marked to identify the damper. Such identification shall also be placed on any required remote controls.

7.6.5 Where ventilation systems penetrate decks, the arrangements shall be such that the effectiveness of the deck in resisting fire is not thereby impaired and precautions shall be taken to reduce the likelihood of smoke and hot gases passing from one between-deck space to another through the system.

7.6.6 All dampers fitted on fire-resisting or smoke-tight divisions shall also be capable of being manually closed from each side of the division in which they are fitted, except for those dampers fitted on ducts serving spaces not normally manned such as stores and toilets that may be manually operated only from outside the served spaces. Manual closing may be achieved by mechanical means of release or by remote operation of the fire or smoke damper by means of a fail-safe electrical switch or pneumatic release (i.e. spring-loaded, etc.). All dampers shall also be capable of being remotely closed from the continuously manned control station.

7.6.7 Ducts shall be made of non-combustible or fire restricting material. Short ducts, however, may be of combustible materials subject to the following conditions:

- .1 their cross-section does not exceed 0.02 m²;
- .2 their length does not exceed 2 m;
- .3 they may only be used at the terminal end of the ventilation system;
- .4 they shall not be situated less than 600 mm from an opening in a fire-resisting or fire-restricting division; and
- .5 their surfaces have low flame spread characteristics.

7.7 Fire detection and extinguishing systems

7.7.1 Fire detection systems

Areas of major and moderate fire hazard and other enclosed spaces not regularly occupied within public spaces and crew accommodation, such as toilets, stairway enclosures, corridors and escape routes shall be provided with an approved automatic smoke detection system and manually operated call points complying with the requirements of 7.7.1.1 and 7.7.1.3 to indicate at the control station the location of outbreak of a fire in all normal operating conditions of the installations. Control stations not normally occupied (e.g., emergency generator rooms) need not be provided with manually operated call points. Detectors operated by heat instead of smoke may be installed in galleys. Main propulsion machinery room(s) shall in addition have detectors sensing other than smoke and be supervised by TV cameras monitored from the operating compartment. Manually operated call points shall be installed throughout the public spaces, crew

accommodation, corridors and stairway enclosures, service spaces and where necessary control stations. One manually operated call point shall be located at each exit from these spaces and from areas of major fire hazard.

7.7.1.1 General requirements

- .1 Any required fixed fire-detection and fire alarm system with manually operated call points shall be capable of immediate operation at all times.
- .2 Power supplies and electric circuits necessary for the operation of the system shall be monitored for loss of power or fault conditions as appropriate. Occurrence of a fault condition shall initiate a visual and audible fault signal at the control panel which shall be distinct from a fire signal.
- .3 There shall be not less than two sources of power supply for the electrical equipment used in the operation of the fixed fire-detection and fire alarm system, one of which shall be an emergency source. The supply shall be provided by separate feeders reserved solely for that purpose. Such feeders shall run to an automatic change-over switch situated in or adjacent to the control panel for the fire-detection system.
- .4 Detectors and manually operated call points shall be grouped into sections, each of which shall comprise a group of fire detectors and manually operated call points as displayed at the indicating unit(s) required by this paragraph. The activation of any detector or manually operated call point shall initiate a visual and audible fire signal at the control panel and indicating units. If the signals have not received attention within two minutes an audible alarm shall be automatically sounded throughout the crew accommodation and service spaces, control stations and machinery spaces. There shall be no time delay for the audible alarms in crew accommodation areas when all the control stations are unattended. The alarm sounder system need not be an integral part of the detection system.
- .5 The control panel shall be located in the operating compartment or in the main fire control station.
- .6 Indicating units shall, as a minimum, denote the section in which a detector or manually operated call point has operated. At least one unit shall be so located that it is easily accessible to responsible members of the crew at all times, when at sea or in port, except when the craft is out of service. One indicating unit shall be located in the

- operating compartment if the control panel is located in the space other than the operating compartment.
- .7 Clear information shall be displayed on or adjacent to each indicating unit about the spaces covered and the location of the sections.
 - .8 Where the fire-detection system does not include means of remotely identifying each detector individually, no section covering more than one deck within public spaces, crew accommodation, corridors, service spaces and control stations shall normally be permitted except a section which covers an enclosed stairway. In order to avoid delay in identifying the source of fire, the number of enclosed spaces included in each section shall be limited as determined by the Administration. In no case shall more than 50 enclosed spaces be permitted in any section. If the detection system is fitted with remotely and individually identifiable fire detectors, the sections may cover several decks and serve any number of enclosed spaces.
 - .9 In passenger craft, if there is no fire-detection system capable of remotely and individually identifying each detector, a section of detectors shall not serve spaces on both sides of the craft nor on more than one deck and neither shall it be situated in more than one zone according to 7.11.1 Notwithstanding the preceding requirements of this paragraph, the Administration may accept that the same section of detectors can serve spaces on more than one deck if such spaces are located in the fore or aft end of the craft or they are so arranged that they constitute common spaces on different decks (e.g., fan rooms, galleys, public spaces, etc.).
 - .10 A section of fire detectors which covers a control station, a service space, a public space, crew accommodation, corridor or stairway enclosure shall not include a machinery space of major fire hazard. In the case of a fire detection system with remotely and individually identifiable fire detectors, this requirement is met if no machinery spaces of a major fire hazard are included in a loop (electrical circuit linking detectors of various sections in a sequence and connected (input and output) to the indicating unit(s)) covering accommodation spaces, service spaces and control stations.
 - .11 Detectors shall be operated by heat, smoke or other products of combustion, flame, or any combination of these factors. Detectors operated by other factors indicative of incipient fires may be considered by the

- Administration provided that they are no less sensitive than such detectors. Flame detectors shall only be used in addition to smoke or heat detectors.
- .12 Suitable instructions and component spares for testing and maintenance shall be provided.
- .13 The function of the detection system shall be periodically tested by means of equipment producing hot air at the appropriate temperature, or smoke or aerosol particles having the appropriate range of density or particle size, or other phenomena associated with incipient fires to which the detector is designed to respond. All detectors shall be of a type such that they can be tested for correct operation and restored to normal surveillance without the renewal of any component.
- .14 The fire-detection system shall not be used for any other purpose, except that the control panel may be used to activate one or more of the following:
- .1 paging system;
 - .2 fan stops;
 - .3 closure of fire doors;
 - .4 closure of fire and smoke dampers; and
 - .5 sprinkler system.
- .15 Fire detection systems in which all fire detectors are individually identifiable (i.e. having zone address identification capability) shall be so arranged that:
- .1 a loop cannot be damaged at more than one point by a fire and no loop shall pass through a space twice. When this is not practical (e.g., for large public spaces), the part of the loop which by necessity passes through the space for a second time shall be installed at the maximum possible distance from the other parts of the loop;
 - .2 means are provided to ensure that any fault (e.g., power break; short circuit; earth) occurring in the loop shall not render the whole loop ineffective;
 - .3 all arrangements are made to enable the initial configuration of the system to be restored in the

event of failure (electrical, electronic, informatic); and

- .4 the first initiated fire alarm shall not prevent any other detector to initiate further fire alarms.
- .16 The fire detection system in vehicle deck spaces, excluding manual call points, may be switched off with a timer during loading/unloading of vehicles.

7.7.1.2 Installation requirements

- .1 In addition to 7.7.1, manually operated call points shall be readily accessible in the corridors of each deck such that no part of the corridor is more than 20 m from a manually operated call point.
- .2 Where a fixed fire-detection and fire alarm system is required for the protection of spaces other than stairways, corridors and escape routes, at least one detector complying with 7.7.1.1.11 shall be installed in each such space.
- .3 Detectors shall be located for optimum performance. Positions near beams and ventilation ducts or other positions where patterns of air flow could adversely affect performance and positions where impact or physical damage is likely shall be avoided. Detectors which are located in the overhead shall be a minimum distance of 0.5 m away from bulkheads, except in corridors, lockers and stairways.
- .4 The maximum spacing of detectors shall be in accordance with the table below:

Type of detector	Maximum floor area per detector	Maximum distance apart between centres	Maximum distance away from bulkheads
Heat	37 m ²	9 m	4.5 m
Smoke	74 m ²	11 m	5.5 m

The Administration may require or permit other spacings based upon test data which demonstrate the characteristics of the detectors.

- .5 Electrical wiring which forms parts of the system shall be so arranged as to avoid machinery spaces of major fire hazard, and other enclosed spaces of major fire hazard except, where it is necessary, to provide for fire detection

or fire alarm in such spaces or to connect to the appropriate power supply.

7.7.1.3 Design requirements

- .1 The system and equipment shall be suitably designed to withstand supply voltage variation and transients, ambient temperature changes, vibration, humidity, shock, impact and corrosion normally encountered in ships.
- .2 Smoke detectors shall be certified to operate before the smoke density exceeds 12.5 % obscuration per metre, but not until the smoke density exceeds 2 % obscuration per metre. Smoke detectors to be installed in other spaces shall operate within sensitivity limits to the satisfaction of the Administration having regard to the avoidance of detector insensitivity or over-sensitivity.
- .3 Heat detectors shall be certified to operate before the temperature exceeds 78°C but not until the temperature exceeds 54°C, when the temperature is raised to those limits at a rate less than 1°C per minute. At higher rates of temperature rise, the heat detector shall operate within temperature limits having regard to the avoidance to detector insensitivity or over-sensitivity.
- .4 At the discretion of the Administration, the permissible temperature of operation of heat detectors may be increased to 30°C above the maximum deckhead temperature in drying rooms and similar spaces of a normal high ambient temperature.
- .5 Flame detectors corresponding to 7.7.1.1.11 shall have a sensitivity sufficient to determine flame against an illuminated space background and a false signal identification system.

7.7.2 Fire detection for periodically unattended machinery spaces

A fixed fire-detection and fire alarm system for periodically unattended machinery spaces shall comply with the following requirements:

- .1 The fire-detection system shall be so designed and the detectors so positioned as to detect rapidly the onset of fire in any part of those spaces and under any normal conditions of operation of the machinery and variations of ventilation as required by the possible range of ambient temperatures. Except in spaces of restricted height and where their use is specially appropriate, detection systems using only thermal detectors shall not be permitted. The detection system shall initiate audible

and visual alarms distinct in both respects from the alarms of any other system not indicating fire, in sufficient places to ensure that the alarms are heard and observed on the navigating bridge and by a responsible engineer officer. When the operating compartment is unmanned the alarm shall sound in a place where a responsible member of the crew is on duty.

- .2 After installation, the system shall be tested under varying conditions of engine operation and ventilation.

7.7.3 Fixed fire-extinguishing systems

7.7.3.1 Areas of major fire hazard shall be protected by an approved fixed fire-extinguishing system operable from the operating compartment and, where provided, from a control position which is adequate for the fire hazard that may exist. The system shall comply with 7.7.3.2 and 7.7.3.3 or with alternative arrangements approved by the Administration taking into account the recommendations and guidelines developed by the Organization²⁸ and be capable of local manual control and remote control from the continuously manned control stations.

7.7.3.2 Additional fixed fire-extinguishing systems not required by the Code, but fitted to the craft are to meet the design requirements of this Code, except for the second discharge required for fixed gas fire-extinguishing systems.

²⁸ Refer to MSC/Circ.668 - Alternative arrangements for halon fire-extinguishing systems in machinery spaces and pump-rooms, and amendments thereto contained in MSC/Circ.728 - Revised test method for equivalent water-based fire extinguishing systems for machinery spaces of category A and cargo pump-rooms contained in MSC/Circ.668; and to MSC/Circ.848 - Revised Guidelines for the approval of equivalent fixed gas fire-extinguishing systems, as referred to in SOLAS 74, for machinery spaces and cargo pump-rooms.

7.7.3.3 General requirements

- .1 In all craft where gas is used as the extinguishing medium, the quantity of gas shall be sufficient to provide two independent discharges. The second discharge into the space shall only be activated manually from a position outside the space being protected. Where the space has a local fire-suppression system installed, based on the guidelines developed by the Organization²⁹, to protect fuel oil, lubricating oil and hydraulic oil located near exhaust manifolds, turbo chargers or similar heated surfaces on main and auxiliary internal combustion engines, a second discharge need not be required.
- .2 The use of a fire-extinguishing medium which, in the opinion of the Administration, either by itself or under expected conditions of use will adversely affect the earth's ozone layer and/or gives off toxic gases in such quantities as to endanger persons shall not be permitted.
- .3 The necessary pipes for conveying fire-extinguishing medium into protected spaces shall be provided with control valves so marked as to indicate clearly the spaces to which the pipes are led. Pipelines may pass through accommodation spaces, provided they are of substantial thickness and their tightness is verified with a pressure test, after their installation, at a pressure head not less than 5 N/mm². In addition, pipelines passing through accommodation areas shall only be joined by welding and shall not be fitted with drains or other openings within such spaces. Pipelines shall not pass through refrigerated spaces. Non-return valves shall be installed in discharge lines between cylinders and manifolds. Suitable provision shall be made to prevent inadvertent admission of the medium to any space.
- .4 The piping for the distribution of fire-extinguishing medium shall be arranged and discharge nozzles so positioned that a uniform distribution of medium is obtained.
- .5 Means shall be provided to close all openings which may admit air to, or allow gas to escape from, a protected space. Openings that may admit air to, or allow gas to

²⁹ Refer to the Guidelines for the approval of water-based local application of fixed fire-suppression systems for use in category A machinery spaces (MSC/Circ.913), and associated interpretation of MSC/Circ.1082.

escape from, a protected space shall be capable of being closed from outside the protected space.

- .6 Where the volume of free air contained in air receivers in any space is such that, if released in such space in the event of fire, such release of air within that space would seriously affect the efficiency of the fixed fire-extinguishing system, the Administration shall require the provision of an additional quantity of fire-extinguishing medium corresponding to the gross volume of the machinery space being increased by the volume of air receivers converted to free air volume. Alternatively, a discharge pipe connected to a safety valve may be fitted to each air receiver, provided it leads directly to the open air.
- .7 Means shall be provided for automatically giving audible warning of the release of fire-extinguishing medium into any space in which personnel normally work or which personnel can be expected to enter (e.g., ro-ro spaces) and where their access is facilitated by doors or hatches or to which they have access. The alarm shall medium is released, but not less than 20 s. Visible alarm shall be arranged in addition to the audible alarm.
- .8 The means of control of any fixed gas fire-extinguishing system shall be readily accessible and simple to operate and shall be grouped together in as few locations as possible at positions not likely to be cut off by a fire in a protected space. At each location there shall be clear instructions relating to the operation of the system, having regard to the safety of personnel.
- .9 Automatic release of fire-extinguishing medium shall not be permitted.
- .10 Where the quantity of extinguishing medium is required to protect more than one space, the quantity of medium available need not be more than the largest quantity required for any one space so protected. Spaces are considered as separated where divisions comply with tables 7.4-1 and 7.4-2, as appropriate, or the divisions are gastight and of steel or equivalent materials.
- .11 Pressure containers required for the storage of fire-extinguishing medium shall be located outside protected spaces in accordance with 7.7.3.2.14. Pressure containers may be located inside the space to be protected if in the event of accidental release persons will not be endangered.

- .12 Means shall be provided for the crew to safely check the quantity of medium in the containers without moving the containers completely from their fixing position.
- .13 Containers for the storage of fire-extinguishing medium and associated pressure components shall be designed having regard to their locations and maximum ambient temperatures expected in service.
- .14 When the fire-extinguishing medium is stored outside a protected space, it shall be stored in a room which shall be situated in a safe and readily accessible location. For the purpose of the application of tables 7.4-1 and 7.4-2, such storage rooms shall be treated as control stations. For the storage rooms for fire-extinguishing media of fixed gas fire-extinguishing systems, the following apply:
 - .1 the storage room shall not be used for any other purposes;
 - .2 if the storage space is located below deck, it shall be located no more than one deck below the open deck and shall be directly accessible by a stairway or ladder from the open deck;
 - .3 spaces shall be effectively ventilated. Spaces which are located below deck or spaces where access from the open deck is not provided, shall be fitted with a mechanical ventilation system designed to take exhaust air from the bottom of the space and shall be sized to provide at least 6 air changes per hour; and
 - .4 access doors shall open outwards, and bulkheads and decks including doors and other means of closing any opening therein, which form the boundaries between such rooms and adjacent enclosed spaces shall be gastight.
- .15 Spare parts for the system shall be stored on board or at a base port.
- .16 If the release of a fire extinguishing medium produces significant over or under pressurisation in the protected space, means shall be provided to limit the induced pressures to acceptable limits to avoid structural damage.

7.7.3.4 Carbon dioxide systems

- .1 For cargo spaces, the quantity of carbon dioxide available shall, unless otherwise provided, be sufficient to give a

minimum volume of free gas equal to 30 % of the gross volume of the largest cargo space so protected in the craft.

.2 For machinery spaces, the quantity of carbon dioxide carried shall be sufficient to give a minimum volume of free gas equal to the larger of the following volumes, either:

.2.1 40 % of the gross volume of the largest machinery space so protected, the volume to exclude that part of the casing above the level at which the horizontal area of the casing is 40 % or less of the horizontal area of the space concerned taken midway between the tank top and the lowest part of the casing; or

.2.2 35 % of the gross volume of the largest machinery space protected, including the casing;

provided that the above-mentioned percentages may be reduced to 35 % and 30 % respectively for cargo craft of less than 2,000 gross tonnage; provided also that if two or more machinery spaces are not entirely separate they shall be considered as forming one space.

.3 For the purpose of this paragraph the volume of free carbon dioxide shall be calculated at 0.56 m³/kg.

.4 For machinery spaces, the fixed piping system shall be such that 85 % of the gas can be discharged into the space within 2 min.

.5 Two separate controls shall be provided for releasing carbon dioxide into a protected space and to ensure the activation of the alarm. One control shall be used to discharge the gas from its storage containers. A second control shall be used for opening the valve of the piping which conveys the gas into the protected spaces.

.6 The two controls shall be located inside a release box clearly identified for the particular space. If the box containing the controls is to be locked, a key to the box shall be in a break-glass type enclosure conspicuously located adjacent to the box.

7.7.4 Portable fire extinguishers

Control stations, public spaces, crew accommodation, corridors and service spaces shall be provided with portable fire extinguishers of approved type

and design. At least five portable extinguishers shall be provided, and so positioned, as to be readily available for immediate use. In addition, at least one extinguisher suitable for machinery space fires shall be positioned outside each machinery space entrance. Each portable fire extinguisher shall:

- .1 not exceed 23 kg in total mass;
- .2 have a capacity of at least 5 kg if of powder or carbon dioxide type;
- .3 have a capacity of at least 9 l if of foam type;
- .4 be examined annually;
- .5 be provided with a sign indicating the date when was last examined;
- .6 be hydraulic-pressure tested (cylinders and propellant bottles) every 10 years;
- .7 not be placed in accommodation spaces if of carbon dioxide type;
- .8 if located in control stations and other spaces containing electrical or electronic equipment or appliances necessary for the safety of the craft, be provided with extinguishing media which are neither electrically conductive nor harmful to the equipment and appliances;
- .9 be ready for use and located in easily visible places such that it can be reached quickly and easily at any time in the event of a fire;
- .10 be located such that its serviceability is not impaired by the weather, vibration or other external factors; and
- .11 be provided with a device to identify whether it has been used.

7.7.5 Fire pumps, fire mains, hydrants and hoses

Fire pumps, and appropriate associated equipment, or alternative effective fire-extinguishing systems shall be fitted as follows:

- .1 At least two pumps powered by independent sources of power shall be arranged. Each pump shall have at least two-thirds the capacity of a bilge pump as determined by 10.3.5 and 10.3.6 but not less than 25 m³/h. Each fire pump shall be able to deliver sufficient quantity and pressure of water to simultaneously operate the hydrants as required by .4.

- .2 The arrangement of the pumps shall be such that in the event of a fire in any one compartment, all the fire pumps will not be put out of action.
- .3 Isolating valves to separate the section of the fire main within the machinery space containing the main fire pump or pumps from the rest of the fire main shall be fitted in an easily accessible and tenable position outside the machinery spaces. The fire main shall be so arranged that when the isolating valves are shut all the hydrants on the craft, except those in the machinery space referred to above, can be supplied with water by a fire pump not located in this machinery space through pipes which do not enter this space. The fire main shall be capable of being drained and shall be fitted with valves arranged so that fire main branches can be isolated when the main is used for purposes other than fire-fighting. The spindles of manually operated valves shall be easily accessible and all valves shall be clearly marked.
- .4 Hydrants shall be so arranged so that any location on the craft can be reached by the water jets from two fire hoses from two different hydrants, one of the jets being from a single length of hose. Ro-ro spaces hydrants shall be located so that any location within the space can be reached by two water jets from two different hydrants, each jet being supplied from a single length of hose. One hydrant shall be located in the vicinity of and outside each entrance to a machinery space.
- .5 Each fire hose shall be of non-perishable material. Fire hoses shall have a length of:
 - .1 at least 10 m;
 - .2 not more than 15 m in machinery spaces; and
 - .3 not more than 20 m for other spaces and open decks.
- .6 Each fire hose shall be provided with a nozzle of an approved dual purpose type (i.e. spray/jet type) incorporating a shutoff.

7.7.6 Protection of deep-fat cooking equipment

Where deep-fat cooking equipment is installed, all such installations shall be fitted with:

- .1 an automatic or manual fixed extinguishing system tested to an appropriate standard acceptable to the Organization³⁰;
- .2 a primary and back up thermostat with an alarm to alert the operator in the event of failure of either thermostat;
- .3 arrangements for automatically shutting off the electrical power to the deep-fat cooking equipment upon activation of the extinguishing system;
- .4 an alarm for indicating operation of the extinguishing system in the galley where the equipment is installed; and
- .5 controls for manual operation of the extinguishing system which are clearly labelled for ready use by the crew.

7.8 Protection of special category spaces and ro-ro spaces

7.8.1 Structural protection

7.8.1.1 Subject to 7.8.1.2 boundaries of special category spaces shall be insulated in accordance with tables 7.4-1 and 7.4-2.

7.8.1.2 The vehicle deck of a special category space or a ro-ro space, including an open ro-ro space, need only be insulated on the underside if required. Vehicle decks located totally within ro-ro spaces may be accepted without structural fire protection, provided these decks are not part of, or do not provide support to, the craft's main load-carrying structure and provided satisfactory measures are taken to ensure that the safety of the craft, including fire-fighting abilities, integrity of fire resisting divisions and means of evacuation, is not affected by a partial or total collapse of these internal decks.

7.8.1.3 Indicators shall be provided on the navigating bridge which shall indicate when any door leading to or from the special category space or ro-ro space is closed.

7.8.1.4 Fire doors in boundaries of special category spaces leading to spaces below the vehicle deck shall be arranged with coamings of a height of at least 100 mm.

³⁰ Refer to ISO 15371 - Ships and marine technology - Fire-extinguishing systems for protection of galley deep-fat cooking equipment - Fire tests.

7.8.2 Fixed fire-extinguishing system

7.8.2.1 Each special category space and ro-ro space shall be fitted with an approved fixed pressure water-spraying system for manual operation which shall protect all parts of any deck and vehicle platform in such space, provided that the Administration may permit the use of any other fixed fire-extinguishing system that has been shown by full-scale test in conditions simulating a flowing petrol fire in the space to be not less effective in controlling fires likely to occur in such a space.

7.8.2.2 The pumps of the system shall be capable of maintaining:

- .1 half the total required application rate with any one pump unit out of function, for category A craft; and
- .2 the total required application rate with any one pump unit out of function, for category B craft.

7.8.2.3 Fixed fire-extinguishing systems shall fulfil the following requirements:

- .1 the valve manifold shall be provided with a pressure gauge, and each of the valves shall be marked to identify the protected areas;
- .2 instructions for maintenance and operation of the installation shall be set up in the room where the valves are located; and
- .3 the piping system shall be provided with a sufficient number of drainage valves.

7.8.3 Patrols and detection

7.8.3.1 A continuous fire patrol shall be maintained in special category spaces and ro-ro spaces unless a fixed fire detection and fire alarm system, complying with the requirements of 7.7.1, and a television surveillance system are provided. The fixed fire detection system shall be capable of rapidly detecting the onset of fire. The spacing and location of detectors shall be tested taking into account the effects of ventilation and other relevant factors.

7.8.3.2 Manually operated call points shall be provided as necessary throughout the special category spaces and ro-ro spaces and one shall be placed close to each exit from such spaces. Manually operated call points shall be spaced so that no part of the space shall be more than 20 m from a manually operated call point.

7.8.4 Fire-extinguishing equipment

7.8.4.1 There shall be provided in each special category space and ro-ro space

- .1 at least three water fog applicators which shall consist of a metal L-shaped pipe, the long limb being approximately 2 m in length and capable of being fitted to a fire hose, and the short limb being approximately 250 mm in length and fitted with a fixed water fog nozzle or capable of being fitted with a water spray nozzle;
- .2 one portable foam applicator unit consisting of an air foam nozzle of an inductor type capable of being connected to the fire main by a fire hose, together with a portable tank containing 20 l of foam-making liquid and one spare tank. The nozzle shall be capable of producing effective foam suitable for extinguishing an oil fire of at least 1.5 m³/min. At least two portable foam applicator units shall be available in the craft for use in such space; and
- .3 portable fire extinguishers of approved type and design shall be located so that no point in the space is more than approximately 15 m walking distance from an extinguisher, provided that at least one portable extinguisher is located at each access to such space. In addition to complying with 7.7.4, fire extinguishers shall be suitable for A and B class fires and have a capacity of 12 kg dry powder or equivalent.

7.8.5 Ventilation system

7.8.5.1 There shall be provided an effective power ventilation system for the special category spaces and ro-ro spaces sufficient to give at least 10 air changes per hour while navigating and 20 air changes per hour at the quayside during vehicle loading and unloading operations. The system for such spaces shall be entirely separated from other ventilation systems and shall be operating at all times when vehicles are in such spaces. Ventilation ducts serving special category spaces and ro-ro spaces capable of being effectively sealed shall be separated for each such space. The system shall be capable of being controlled from a position outside such spaces.

7.8.5.2 The ventilation shall be such as to prevent air stratification and the formation of air pockets.

7.8.5.3 Means shall be provided to indicate in the operating compartment any loss or reduction of the required ventilating capacity.

7.8.5.4 Arrangements shall be provided to permit a rapid shutdown and effective closure of the ventilation system in case of fire, taking into account the weather and sea conditions.

7.8.5.5 Ventilation ducts, including dampers, shall be made of steel or other equivalent material. Ducts lying inside the served space may be made of non-combustible or fire-restricting material.

7.8.6 Scuppers, bilge pumping and drainage

7.8.6.1 In view of the serious loss of stability which could arise due to large quantities of water accumulating on the deck or decks consequent to the operation of the fixed pressure water-spraying system, pumping and drainage arrangements shall be such as to prevent such accumulation. Scuppers fitted for this purpose shall be so arranged as to ensure that such water is rapidly discharged directly overboard. Alternatively, pumping and drainage facility shall be provided additional to the requirements of chapter 10. When it is required to maintain watertight or weathertight integrity, as appropriate, the scuppers shall be arranged so that they can be operated from outside the space protected.

7.8.7 Precautions against ignition of flammable vapours or liquids

7.8.7.1 On any deck or platform, if fitted, on which vehicles are carried and on which explosive vapours might be expected to accumulate, except platforms with openings of sufficient size permitting penetration of petrol gases downwards, equipment which may constitute a source of ignition of flammable vapours and, in particular, electrical equipment and wiring, shall be installed at least 450 mm above the deck or platform. Electrical equipment installed more than 450 mm above the deck or platform shall be of a type enclosed and protected by an enclosure having an ingress protection based on an international standard acceptable to the Organization³¹. However, if the installation of electrical equipment and wiring less than 450 mm above the deck or platform is necessary for the safe operation of the craft, such electrical equipment and wiring may be installed provided that the equipment is certified "safe type" based on an international standard acceptable to the Organization³².

7.8.7.2 If installed in an exhaust ventilation duct, electrical equipment shall be certified "safe type"³³. The equipment and wiring, if fitted, shall be suitable for use based on standards acceptable to the Organization*** and the outlet from any exhaust duct shall be sited in a safe position, having regard to other possible sources of ignition."

7.8.7.3 If pumping and drainage arrangements are provided, it shall be ensured that:

³¹ Refer to the publication IEC 60079 series – Electrical apparatus for explosive gas atmospheres, in particular, refer to the standards for equipment and wiring to be suitable for use in zone 1 areas.

³² Refer to the publication IEC 60092.

³³ Refer to zone 1 areas as defined in the publication IEC 60079 series.

- .1 water contaminated with petrol or other flammable substances is not drained to machinery spaces or other spaces where sources of ignition may be present; and
- .2 electrical equipment fitted in tanks or other components of the drainage system shall be of a type suitable for use in explosive petrol/air mixtures.

7.8.8 Open ro-ro spaces

7.8.8.1 Open ro-ro spaces shall comply with the requirements set out in 7.8.1.1, 7.8.2, 7.8.3, 7.8.4 and 7.8.6.

7.8.8.2 For those parts of a ro-ro space which are completely open from above, the requirements set out in 7.8.2, 7.8.3.1 and 7.8.6 need not be complied with. However, a continuous fire patrol or a television surveillance system shall be maintained.

7.9 Miscellaneous

7.9.1 There shall be permanently exhibited, for the guidance of the master and officers of the craft, fire control plans showing clearly for each deck the following positions: the control stations, the sections of the craft which are enclosed by fire-resisting divisions together with particulars of the fire alarms, fire detection systems, the sprinkler installations, the fixed and portable fire-extinguishing appliances, the means of access to the various compartments and decks in the craft, the ventilating system (including particulars of the master fan controls, the positions of dampers and identification numbers of the ventilating fans serving each section of the craft), the location of the international shore connection, if fitted, and the position of all means of control referred to in 7.5.3, 7.6.2, 7.7.1 and 7.7.3.1. The text of such plans³⁴ shall be in the official language of the flag state. However, if the language is not English, French or Spanish, a translation into one of those languages shall be included.

7.9.2 A duplicate set of fire control plans or a booklet containing such plans shall be permanently stored in a prominently marked weathertight enclosure outside the deckhouse for the assistance of shore-side fire-fighting personnel.

³⁴ Refer to Graphical Symbols for Fire Control Plans, adopted by the Organization by resolution A.654(16).

7.9.3 Openings in fire resisting divisions

7.9.3.1 Except for any hatches between cargo, special category, ro-ro, store, and baggage spaces and between such spaces and the weather decks, all openings shall be provided with permanently attached means of closing which shall be at least as effective for resisting fires as the divisions in which they are fitted.

7.9.3.2 It shall be possible for each door to be opened and closed from each side of the bulkhead by one person only.

7.9.3.3 Fire doors bounding areas of major fire hazard and stairway enclosures shall satisfy the following requirements:

- .1 The doors shall be self-closing and be capable of closing with an angle of inclination of up to 3.5° opposing closure. The approximate time of closure for hinged fire doors shall be no more than 40 s and no less than 10 s from the beginning of their movement with the craft in the upright position. The approximate uniform rate of closure for sliding fire doors shall be of no more than 0.2 m/s and no less than 0.1 m/s with the craft in the upright position.
- .2 Remote released sliding or power-operated doors shall be equipped with an alarm that sounds at least 5 s but no more than 10 s after the door is released from the continuously manned control station and before the door begins to move and continue sounding until the door is completely closed. Doors designed to reopen upon contacting an object in their paths shall re-open no more than 1 m from the point of contact.
- .3 All doors shall be capable of remote release from a continuously manned central control station, either simultaneously or in groups, and shall be capable of release also individually from a position at both sides of the door. Indication shall be provided at the fire door indicator panel in the continuously manned control station whether each of the remote released doors is closed. The release mechanism shall be so designed that the door will automatically close in the event of disruption of the control system or main source of electrical power. Release switches shall have an on-off function to prevent automatic resetting of the system. Hold-back hooks not subject to continuously manned control station release shall be prohibited.
- .4 A door closed remotely from the continuously manned control station shall be capable of being re-opened at

both sides of the door by local control. After such local opening, the door shall automatically close again.

- .5 Local power accumulators for power-operated doors shall be provided in the immediate vicinity of the doors to enable the doors to be operated after disruption of the control system or main source of electric power at least ten times (fully opened and closed) using the local controls.
- .6 Disruption at one door of the control system or main source of electric power shall not impair the safe functioning of the other doors.
- .7 Double-leaf doors equipped with a latch necessary to their fire integrity shall have a latch that is automatically activated by the operation of the doors when released by the system.
- .8 Doors giving direct access to special category spaces which are power-operated and automatically closed need not be equipped with alarms and remote-release mechanisms required in .2 and .3.
- .9 The components of the local control system shall be accessible for maintenance and adjusting.
- .10 Power operated doors shall be provided with a control system of an approved type which shall be able to operate in case of fire, this being determined in accordance with the Fire Test Procedures Code. This system shall satisfy the following requirements:
 - .1 the control system shall be able to operate at a temperature of at least 200°C for at least 60 min, served by the power supply;
 - .2 the power supply for all other doors not subject to fire shall not be impaired; and
 - .3 at temperatures exceeding 200°C the control system shall be automatically isolated from the power supply and shall be capable of keeping the door closed up to at least 945°C.

7.9.3.4 The requirements for integrity of fire-resisting divisions of the outer boundaries facing open spaces of a craft shall not apply to glass partitions, windows and side scuttles. Similarly, the requirements for integrity of fire-resisting divisions facing open spaces shall not apply to exterior doors in superstructures and deck houses.

7.9.3.5 Doors in smoke-tight divisions shall be self-closing. Doors which are normally kept open shall close automatically or by remote control from a continuously manned control station.

7.10 Firefighter's outfits

7.10.1 All craft other than category A passenger craft shall carry at least two firefighter's outfits complying with the requirements of 7.10.3.

7.10.1.1 In addition, there shall be provided in category B passenger craft for every 80 m, or part thereof, of the aggregate of the length of all passenger spaces and service spaces on the deck which carries such spaces or, if there is more than one such deck, on the deck which has the largest aggregate of such length, two firefighter's outfits and two sets of personal equipment, each comprising the items stipulated in 7.10.3.1.1 to 7.10.3.1.3.

7.10.1.2 In category B passenger craft, for each pair of breathing apparatuses there shall be provided one water fog applicator complying with the requirements of 7.8.4.1, which shall be stored adjacent to such apparatus.

7.10.1.3 The Administration may require additional sets of personal equipment and breathing apparatus, having due regard to the size and type of the craft.

7.10.2 The firefighter's outfits and sets of personal equipment shall be stored in permanently and clearly marked locations arranged so as to be easily accessible and ready for use and, where more than one firefighter's outfit or more than one set of personal equipment is carried, they shall be stored in widely separated positions.

7.10.3 A firefighter's outfit shall consist of:

- .1 Personal equipment comprising:
 - .1.1 protective clothing of material to protect the skin from the heat radiating from the fire and from burns and scalding by steam or gases. The outer surface shall be water-resistant;
 - .1.2 boots of rubber or other electrically non-conductive material;
 - .1.3 a rigid helmet providing effective protection against impact;

- .1.4 an electric safety lamp (hand lantern) of an approved explosion-proof type certified to a standard acceptable to the Organization³⁵ with a minimum burning period of 3 h; and
- .1.5 an axe having handle provided with high-voltage insulation.
- .2 A self-contained compressed-air-operated breathing apparatus of an approved type, the volume of air contained in the cylinders of which shall be at least 1,200 l, or other self-contained breathing apparatus, which shall be capable of functioning for at least 30 min. Two spare charges suitable for use with the apparatus shall be provided for each required apparatus
- .3 For each breathing apparatus a fireproof lifeline of approximately 30 m in length and strength shall be provided capable of being attached by means of a snaphook to the harness of the apparatus or to a separate belt in order to prevent the breathing apparatus becoming detached when the lifeline is operated.

³⁵ Refer to gas group II A and temperature class T 3 of the publication IEC 60079 series.

PART B - REQUIREMENTS FOR PASSENGER CRAFT

7.11 Arrangement

7.11.1 For category B craft, the public spaces shall be divided into zones according to the following:

- .1 The craft shall be divided into at least two zones. The mean length of each zone shall not exceed 40 m.
- .2 For the occupants of each zone there shall be an alternative safe area to which it is possible to escape in case of fire. The alternative safe area shall be separated from other passenger zones by smoke-tight divisions of non-combustible materials or fire-restricting materials extending from deck to deck. The alternative safe area can be another passenger zone. Alternative safe areas shall be dimensioned on the basis of one person per seat and 0.35 m² per person of the net remaining area, based on the maximum number of persons they are called to accommodate in an emergency.
- .3 The alternative safe area shall, as far as practicable, be located adjacent to the passenger zone it is intended to serve. There shall be at least two exits from each passenger zone, located as far away from each other as possible, leading to the alternative safe area. Escape routes shall be provided to enable all passengers and crew to be safely evacuated from the alternative safe area within the structural fire protection time for areas of major fire hazard.

7.11.2 Category A craft need not be divided into zones.

7.11.3 Control stations, stowage positions of life-saving appliances, escape routes and places of embarkation into survival craft shall not, as far as practicable, be located adjacent to any areas of major or moderate fire hazard.

7.12 Ventilation

Each safe zone in the public spaces shall be served by a ventilation system independent of the ventilation system of any other zone. The ventilation fans of each zone in the public spaces shall also be capable of being independently controlled from a continuously manned control station.

7.13 Fixed sprinkler system

7.13.1 Public spaces and service spaces, crew accommodation areas where sleeping berths are provided, storage rooms other than those containing flammable liquids, and similar spaces shall be protected by a fixed sprinkler system based on the standards developed by the Organization³⁶. A stairway open at one deck shall be considered part of the space to which it is open and consequently shall be protected by any sprinkler system provided for that space. Manually operated sprinkler systems shall be divided into sections of appropriate size and the valves for each section, start of sprinkler pump(s) and alarms shall be capable of being operated from two spaces separated as widely as possible, one of which shall be a continuously manned control station. In category B craft, no section of the system shall serve more than one of the zones required in 7.11.

7.13.2 Plans of the system shall be displayed at each operating station. Suitable arrangements shall be made for the drainage of water discharged when the system is activated.

7.13.3 Category A craft need not comply with the requirements of 7.13.1 and 7.13.2 providing that:

- smoking is not permitted;
- sales shops, galleys, service spaces, ro-ro spaces and cargo spaces are not fitted;
- the maximum number of passengers carried does not exceed 200; and
- the voyage duration at 90 % of maximum speed from departure port to destination when fully laden does not exceed 2 h.

PART C - REQUIREMENTS FOR CARGO CRAFT

7.14 Control stations

Control stations, life-saving appliances stowage positions, escape routes and places of embarkation into survival craft shall be located adjacent to crew accommodation areas.

³⁶ Refer to the Standards for fixed sprinkler systems for high speed craft, adopted by the Organization by resolution MSC.44(65), as may be amended, and the associated interpretation of MSC/Circ.912.

7.15 Cargo spaces

Cargo spaces, except open deck areas or refrigerated holds, shall be provided with an approved automatic smoke-detection system complying with 7.7.1 to indicate at the control station the location of outbreak of a fire in all normal operating conditions of the installations and shall be protected by an approved fixed quick-acting fire-extinguishing system complying with 7.7.3.2 operable from the control station.

7.16 Fixed sprinkler system

7.16.1 Crew accommodation where sleeping berths are provided, having a total deck area greater than 50 m² (including corridors serving such accommodation), shall be protected by a fixed sprinkler system based on the standards developed by the Organization³⁷.

7.16.2 Plans of the system shall be displayed at each operating station. Suitable arrangements shall be made for the drainage of water discharged when the system is activated.

PART D - REQUIREMENTS FOR CRAFT AND CARGO SPACES INTENDED FOR THE CARRIAGE OF DANGEROUS GOODS*

7.17 General

7.17.1 In addition to complying with the requirements of paragraph 7.15 for cargo craft and with the requirements of paragraph 7.8 for both passenger and cargo craft as appropriate, craft types and cargo spaces referred to in 7.17.2 intended for the carriage of dangerous goods shall comply with the requirements of this paragraph, as appropriate, except when carrying dangerous goods in limited quantities³⁸, unless such requirements have already been met by compliance with the requirements elsewhere in this chapter. The types of craft and modes of carriage of dangerous goods are referred to in 7.17.2 and in table 7.17-1, where the numbers appearing in 7.17.2 are referred to in the top line. Cargo craft of less than 500 gross tonnage constructed on or after 1 July 2002 shall comply with this

³⁷ Refer to the Standards for fixed sprinkler systems for high speed craft, adopted by the Organization by resolution MSC.44(65), as may be amended, and the associated interpretation of MSC/Circ.912..

* Refer to the Standards for fixed sprinkler systems for high speed craft, adopted by the Organization by resolution MSC.44(65), as may be amended, and the associated interpretation of MSC/Circ.912..

³⁸ Refer to chapter 3.4 of the International Maritime Dangerous Goods Code (IMDG Code) for the provisions on the carriage of "limited quantities".

paragraph, but the Administration of the State whose flag the craft is entitled to fly may, in consultation with the port State, reduce the requirements and such reduced requirements shall be recorded in the document of compliance referred to in 7.17.4. Craft constructed on or after 1 July 2002 but before 1 January 2011 with cargo spaces intended for the carriage of packaged dangerous goods, shall comply with 7.13.3³⁹, except when carrying dangerous goods specified as classes 6.2 and 7 and dangerous goods in limited quantities⁴⁰ and excepted quantities⁴¹ in accordance with tables 7.17-1 and 7.17-3, not later than the date of the first renewal survey on or after 1 January 2011.

7.17.2 Application of tables 7.17-1 and 7.17-2

The following craft types and cargo spaces shall govern the application of tables 7.17-1 and 7.17-2:

- .1 craft and cargo spaces not specifically designed for the carriage of freight containers but intended for the carriage of dangerous goods in packaged form including goods in freight containers and portable tanks;
- .2 purpose-built container craft and cargo spaces intended for the carriage of dangerous goods in freight containers and portable tanks. In this regard, a purpose-built container space is a cargo space fitted with cell guides for stowage and securing containers;”
- .3 craft and ro-ro spaces, including special category spaces, intended for the carriage of dangerous goods; and
- .4 craft and cargo spaces intended for the carriage of solid dangerous goods in bulk.

7.17.3 Requirements

Unless otherwise specified the following requirements shall govern the application of tables 7.17-1, 7.17-2 and 7.17-3 to both "on deck" and "under deck" stowage of dangerous goods. The numbers of the following sub-sections are indicated in the first column of the above-mentioned tables. For the purpose of this section, "on deck" shall be taken to mean spaces on the weather deck.

³⁹ Med anledning av att texten är införlivad direkt från resolution MSC.271(85) måste här påpekas att hänvisningen är felaktig och egentligen avses 7.17.3.

⁴⁰ Refer to chapter 3.4 of the IMDG Code.

⁴¹ Refer to chapter 3.5 of the IMDG Code.

TABLE 7.17-1

Application of the requirements of 7.17.3 to different modes of carriage of dangerous goods in craft and cargo spaces

Section 7.17.2 Section 7.17.3	Weather decks 1 to 4 inclusive	7.17.2.1	7.17.2.2	7.17.2.3		7.17.2.4
		Not specifically designed	Container cargo spaces	Ro-ro spaces	Open ro-ro spaces	Solid dangerous goods in bulk (includes cargo group B of the Code of Safe Practice for Ships Carrying Bulk Cargoes, 2009, except for cargoes denoted Material Hazardous in Bulk)
7.17.3.1.1	x	x	x	x	x	For application of requirements of Part 7.17.3 to different classes of dangerous goods as given in table 7.17-2.
7.17.3.1.2	x	x	x	x	x	
7.17.3.1.3	-	x	x	x	x	
7.17.3.1.4	-	x	x	x	x	
7.17.3.2	-	x	x	x	x	
7.17.3.3	-	x	x	x	-	
7.17.3.4.1	-	x	x ¹	x	-	
7.17.3.4.2	-	x	x ¹	x	-	
7.17.3.5	-	x	x	x	-	
7.17.3.6.1	x	x	x	x	x	
7.17.3.6.2	x	x	x	x	x	
7.17.3.7	x	x	-	-	x	
7.17.3.8.1	-	x	x	x	-	
7.17.3.8.2	-	-	-	x ²	x	
7.17.3.9	-	-	-	x	x	
7.17.3.10	x	-	-	x	x	

NOTES:

- 1** For classes 4 and 5.1 solids not applicable to closed freight containers. For classes 2, 3, 6.1 and 8 when carried in closed freight containers the ventilation rate may be reduced to not less than two air changes per hour. For classes 4 and 5.1 liquids when carried in closed freight containers, the ventilation rate may be reduced to not less than two air changes per hour. For the purpose of this requirement a portable tank is a closed freight container.
- 2** Applies only to ro-ro spaces, not capable of being sealed.

x Wherever "x" appears in the table it means that this requirement is applicable to all classes of dangerous goods as given in the appropriate line of table 7.17-3, except as indicated by the notes.

TABLE 7.17-2

**Application of the requirements of 7.17.3 to different classes
of dangerous goods for craft and cargo spaces
carrying solid dangerous goods in bulk**

Class	4.1	4.2	4.3³	5.1	6.1	8	9
Section							
7.17.3.1.1	x	x	-	x	-	-	x
7.17.3.1.2	x	x	-	x	-	-	x
7.17.3.2	x	x ⁴	x	x ⁵	-	-	x ⁵
7.17.3.4.1	-	x ⁴	x	-	-	-	-
7.17.3.4.2	x ⁶	x ^{4,7}	x ⁷	x ^{4,6}	-	-	x ^{4,6}
7.17.3.4.4	x	x	x	x	x	x	x
7.17.3.6	x	x	x	x	x	x	x

NOTES:

- 3** The hazards of substances in this Class which may be carried in bulk are such that special consideration must be given by the Administration to the construction and equipment of the craft involved in addition to meeting the requirements enumerated in this Table.
- 4** Only applicable to seedcake containing residues of solvent extractions, to Ammonium nitrate and to Ammonium nitrate fertilizers.
- 5** Only applicable to Ammonium nitrate and to Ammonium nitrate fertilizers. However, a degree of protection in accordance with standards contained in the "International Electrotechnical Commission, publication 79 - Electrical Apparatus for Explosive Gas Atmospheres", is sufficient.
- 6** Only suitable wire mesh guards are required.
- 7** For seedcake containing residues of solvent extraction and cargoes of BC Code Class 4.3, two separate fans shall be permanently fitted unless portable type fans have been adapted for being securely fitted (e.g., fixed) prior to loading and during the voyage. The ventilation system shall comply with the provisions of 7.17.3.4.1 and 7.17.3.4.2. Ventilation shall be such that any escaping gases cannot reach public spaces or crew accommodation on or under deck.

TABLE 7.17-3 Application of the requirements of section 7.17.3 to different classes of dangerous goods except solid dangerous goods in bulk

Section \ Class	1.1 to 1.6 ⁹	1.4S	2.1	2.2	2.3 flammable ¹⁷	2.3 non-flammable	3 FP ¹² <23°C	3 FP ¹² ≥23°C to ≤60°C	4.1	4.2	4.3 liquids ¹⁸	4.3 solids	5.1 ¹⁰	5.2 ¹³	6.1 liquids FP ¹² <23°C	6.1 liquids FP ¹² ≥23°C to ≤60°C	6.1 liquids	6.1 solids	8 liquids FP ¹² <23°C	8 liquids FP ¹² ≥23°C to ≤60°C	8 liquids	8 solids	9
7.17.3.1.1	x	x	x	x	x	x	x	x	x	x	x	x	x	x	x	x	x	x	x	x	x	x	x
7.17.3.1.2	x	x	x	x	x	x	x	x	x	x	x	x	x	x	x	x	x	x	x	x	x	x	-
7.17.3.1.3	x	-	-	-	-	-	-	-	-	-	-	-	-	-	-	-	-	-	-	-	-	-	-
7.17.3.1.4	x	-	-	-	-	-	-	-	-	-	-	-	-	-	-	-	-	-	-	-	-	-	-
7.17.3.2	x	-	x	-	x	-	x	-	-	-	x ¹⁵	-	-	-	x	-	-	-	x	-	-	-	x ¹⁴
7.17.3.3	x	x	x	x	-	x	x	x	x	x	x	x	x	-	x	x	x	x	x	x	x	x	-
7.17.3.4.1	-	-	x	-	-	x	x	-	x ⁸	x ⁸	x	x	x ⁸	-	x	x	-	x ⁸	x	x	-	-	x ⁸
7.17.3.4.2	-	-	x	-	-	-	x	-	-	-	-	-	-	-	x	-	-	-	x	-	-	-	x ¹⁴
7.17.3.5	-	-	-	-	-	-	x	-	-	-	-	-	-	-	x	x	x	-	x	x ¹⁶	x ¹⁶	-	-
7.17.3.6	-	-	x	x	x	x	x	x	x	x	x	x	x	x	x	x	x	x	x	x	x	x	x ¹¹
7.17.3.7	-	-	-	-	-	-	x	x	x	x	x	x	x	-	x	x	-	-	x	x	-	-	-
7.17.3.8	x ⁹	x	x	x	x	x	x	x	x	x	x	x	x ¹⁰	x	x	x	x	x	x	x	x	x	x
7.17.3.9	x	x	x	x	x	x	x	x	x	x	x	x	x	x	x	x	x	x	x	x	x	x	x
7.17.3.10	x	x	x	x	x	x	x	x	x	x	x	x	x	x	x	x	x	x	x	x	x	x	x

NOTES:

- 8 When "mechanically-ventilated spaces" are required by the IMDG Code.
- 9 Stow 3 m horizontally away from the machinery space boundaries in all cases.
- 10 Refer to the IMDG Code.
- 11 As appropriate for the goods to be carried.
- 12 FP means flashpoint.
- 13 Under the provisions of the IMDG Code, stowage of class 5.2 dangerous goods under deck or in enclosed ro-ro spaces is prohibited.

7.17.3.1 Water supplies

7.17.3.1.1 Arrangements shall be made to ensure immediate availability of a supply of water from the fire main at the required pressure either by permanent pressurization or by suitably placed remote starting arrangements for the fire pumps.

7.17.3.1.2 The quantity of water delivered shall be capable of simultaneously supplying the arrangements required by 7.17.3.1.3 for the largest designated cargo space and the four nozzles of a size and at a pressure as specified in 7.7.5, capable of being trained on any part of the cargo space when empty. This requirement shall be met by the total capacity of the main fire pump(s) not including the capacity of the emergency fire pump, if fitted. This amount of water may be applied by equivalent means to the satisfaction of the Administration.

7.17.3.1.3 Means shall be provided of effectively cooling the designated under deck cargo space by with water at not less than 5 l/min/m^2 of the horizontal area of cargo spaces, either by a fixed arrangement of spraying nozzles, or flooding the space with water. Hoses may be used for this purpose in small cargo spaces and in small areas of larger cargo-spaces at the discretion of the Administration. In any event the drainage and pumping arrangements shall meet the requirements of 7.8.6 and be such as to prevent the build-up of free surfaces. If this is not possible the adverse effect upon stability of the added weight and free surface of water shall be taken into account.

7.17.3.1.4 Provision to flood a designated under deck cargo-space with suitable specified media may be substituted for the requirements in 7.17.3.1.3 above. Substitution by a high expansion foam system complying with regulation II-2/10.4.1.1.2 of the Convention is also acceptable.

7.17.3.1.5 The requirements of 7.17.3.1.1 to 7.17.3.1.4 may be fulfilled by a water spray system approved by the Administration based on the standards developed by the Organization⁴², provided that the amount of water required for fire-fighting purposes in the largest cargo space allows simultaneous use of the water spray system plus four jets of water from hose nozzles in accordance with 7.17.3.1.2.

7.17.3.1.6 Craft carrying dangerous goods shall be provided with three fire hoses and nozzles complying with 7.7.5.6 in addition to those required by 7.7.5.5.

⁴² Refer to paragraphs 9.2, 9.3 and 9.4 of the Interim guidelines for open-top containerships (MSC/Circ.608/Rev.1).

7.17.3.2 Sources of ignition

Electrical equipment and wiring shall not be fitted in enclosed cargo spaces or vehicle decks, unless it is essential for operational purposes. However, if electrical equipment is fitted in such spaces, it shall be of a certified safe type⁴³ for use in the dangerous environments to which it may be exposed unless it is possible to completely isolate the electrical system (by removal of links in the system, other than fuses). Cable penetrations of the decks and bulkheads shall be sealed against the passage of gas or vapour. Through runs of cables and cables within the cargo spaces shall be protected against damage from impact. Any other equipment which may constitute a source of ignition of flammable vapour shall not be permitted.

7.17.3.3 Detection system

Enclosed cargo spaces shall be provided with an approved automatic smoke detection system complying with 7.7.1 or with a detection system which, in the opinion of the Administration gives equivalent protection.

7.17.3.4 Ventilation

7.17.3.4.1 Adequate power ventilation shall be provided in enclosed spaces. The arrangement shall be such as to provide for at least six air changes per hour in the cargo space based on an empty space and for removal of vapours from the upper or lower parts of the space, as appropriate.

7.17.3.4.2 The fans shall be such as to avoid the possibility of ignition of flammable gas air mixtures. Exhaust fans shall be of non-sparking type. Suitable wire mesh guards having a mesh size not exceeding 13 mm x 13 mm shall be fitted over inlet and outlet ventilation openings to prevent foreign objects from entering into the casing.

7.17.3.4.3 If adjacent spaces are not separated from cargo spaces by gastight bulkheads or decks, ventilation requirements shall apply to the adjacent spaces as for the cargo space itself.

7.17.3.4.4 Natural ventilation shall be provided in enclosed spaces intended for the carriage of solid dangerous goods in bulk, where there is no provision for mechanical ventilation.

7.17.3.4.5 For open-top container craft, power ventilation is required only for the lower part of the cargo hold for which purpose-built ducting is

⁴³ Refer to IEC publication 92-506 Electrical installations in ships Part 506: Special features-Ships carrying specific dangerous goods and materials hazardous only in bulk and IEC 79-Electrical apparatus for explosive gas atmospheres.

required. The ventilation rate shall be at least two air changes per hour based on the empty hold volume below the weather deck.

7.17.3.5 Bilge pumping

Where it is intended to carry flammable or toxic liquids in enclosed spaces, the bilge pumping system shall be designed to ensure against inadvertent pumping of such liquids through machinery space piping or pumps. Where large quantities of such liquids are carried, consideration shall be given to the provision of additional means of draining those spaces as follows:

- .1 if the bilge drainage system for cargo spaces is additional to the system served by pumps in the machinery space, the capacity of the system shall be not less than than 10 m³/h per cargo space served. If the additional system is a common system, the capacity need not exceed 25 m³/h. The additional bilge system need not be arranged with redundancy. Whenever flammable or toxic liquids are carried, the bilge line into the machinery space shall be isolated either by fitting a blank flange or by a closed lockable valve;
- .2 if bilge drainage of cargo spaces is arranged by gravity drainage, the drainage shall be either lead directly overboard or to a closed drain tank located outside the machinery spaces. The tank shall be provided with vent pipe to a safe location on the open deck;
- .3 enclosed spaces outside machinery spaces containing bilge pumps serving cargo spaces intended for carriage of flammable or toxic liquids shall be fitted with separate mechanical ventilation giving at least six air changes per hour. Electrical equipment in the space shall be of certified safe type⁴⁴.* If the space has access from another enclosed space, the door shall be self-closing; and
- .4 drainage from a cargo space into bilge wells in a lower space is only permitted if that space satisfies the same requirements as the cargo space above.

7.17.3.6 Personnel protection

7.17.3.6.1 Four sets of full protective clothing resistant to chemical attack shall be provided in addition to the firefighter's outfits required by

⁴⁴ Refer to publication IEC 60092-506: Special features – Ships carrying dangerous goods and materials hazardous only in bulk.

7.10 and shall be selected taking into account the hazards associated with the chemicals being transported and the standards developed by the Organization according to the class and physical state.”. The protective clothing shall cover all skin, so that no part of the body is unprotected.

7.17.3.6.2 At least two self-contained breathing apparatuses additional to those required by 7.10 shall be provided. In addition to the requirements of 7.10.3.2.2, two spare charges suitable for use with the breathing apparatus shall be provided for each required apparatus.

7.17.3.7 Portable fire extinguishers

Portable fire extinguishers with a total capacity of at least 12 kg of dry powder or equivalent shall be provided for the cargo spaces. These extinguishers shall be in addition to any portable fire extinguishers required elsewhere in this chapter.

7.17.3.8 Fixed fire extinguishing system

7.17.3.8.1 Cargo spaces, except for open decks, shall be provided with an approved fixed fire extinguishing system complying with the provisions of 7.7.3 or with a fire extinguishing system which, in the opinion of the Administration, gives equivalent protection for the cargo carried⁴⁵.

7.17.3.8.2 Each open ro-ro space having a deck above it and each ro-ro space not capable of being sealed shall be fitted with an approved fixed pressure water-spraying system for manual operation which shall protect all parts of any deck and vehicle platform in such space, except that the Administration may permit the use of any other fixed fire-extinguishing system that has been shown by full-scale test to be no less effective. In any event the drainage and pumping arrangements shall meet the requirements of 7.8.6, have valves operable from outside the space at a position in the vicinity of the extinguishing system controls and be such as to prevent the build-up of free surfaces. If this is not possible the adverse effect upon stability of the added weight and free surface of water shall be taken into account to the extent deemed necessary by the Administration in its approval of the stability information.

⁴⁵ For cargoes for which a fixed gas fire extinguishing system is ineffective, refer to the List of cargoes in table 2 of MSC/Circ.671.

7.17.3.9 Separation between ro-ro spaces and open ro-ro spaces

A separation shall be provided between a ro-ro space and an adjacent open ro-ro space. The separation shall be such as to minimize the passage of dangerous vapours and liquids between such spaces. Alternatively, such separation need not be provided if both spaces fully comply with the requirements for ro-ro spaces in Part D.

7.17.3.10 Separation between ro-ro spaces and weather decks

A separation shall be provided between a ro-ro space and the adjacent weather deck. The separation shall be such as to minimize the passage of dangerous vapours and liquids between such spaces. Alternatively, a separation need not be provided if the ro-ro space fully complies with the requirements for ro-ro spaces in Part D. However, a separation is still required when dangerous goods carried shall be loaded on the weather deck only.

7.17.4 Document of compliance

The Administration shall provide the craft with an appropriate document as evidence of compliance of construction and equipment with the requirements of this Part D⁴⁶.

⁴⁶ Refer to MSC/Circ.1148 – Issuing and renewal of document of compliance with the special requirements applicable to ships carrying dangerous goods.

CHAPTER 8

Life-Saving Appliances and Arrangements

8.1 General and definitions

8.1.1 Life-saving appliances and arrangements shall enable abandonment of the craft in accordance with the requirements of 4.7 and 4.8.

8.1.2 Except where otherwise provided in this Code, the life-saving appliances and arrangements required by this chapter shall meet the detailed specifications set out in chapter III of the Convention and the LSA Code and be approved by the Administration.

8.1.3 Before giving approval to life-saving appliances and arrangements, the Administration shall ensure that such life-saving appliances and arrangements:

- .1 are tested to confirm that they comply with the requirements of this chapter, in accordance with the recommendations of the Organization⁴⁷; or
- .2 have successfully undergone, to the satisfaction of the Administration, tests which are substantially equivalent to those specified in those recommendations.

8.1.4 Before giving approval to novel life-saving appliances or arrangements, the Administration shall ensure that such appliances or arrangements:

- .1 provide safety standards at least equivalent to the requirements of this chapter and have been evaluated and tested in accordance with the recommendations of the Organization⁴⁸; or
- .2 have successfully undergone, to the satisfaction of the Administration, evaluation and tests which are substantially equivalent to those recommendations.

⁴⁷ Refer to the Revised Recommendation on Testing of Life-Saving Appliances, adopted by the Organization by resolution MSC.81(70).

⁴⁸ Refer to the Code of Practice for the Evaluation, Testing and Acceptance of Prototype Novel Life-Saving Appliances and Arrangements, adopted by the Organization by resolution A.520(13).

8.1.5 Before accepting life-saving appliances and arrangements that have not been previously approved by the Administration, the Administration shall be satisfied that life-saving appliances and arrangements comply with the requirements of this chapter.

8.1.6 Except where otherwise provided in this Code, life-saving appliances required by this chapter for which detailed specifications are not included in the LSA Code shall be to the satisfaction of the Administration.

8.1.7 The Administration shall require life-saving appliances to be subjected to such production tests as are necessary to ensure that the life-saving appliances are manufactured to the same standard as the approved prototype.

8.1.8 Procedures adopted by the Administration for approval shall also include the conditions whereby approval would continue or would be withdrawn.

8.1.9 The Administration shall determine the period of acceptability of life-saving appliances which are subject to deterioration with age. Such life-saving appliances shall be marked with a means for determining their age or the date by which they shall be replaced.

8.1.10 For the purposes of this chapter, unless expressly provided otherwise:

- .1 "Detection" is the determination of the location of survivors or survival craft.
- .2 "Embarkation ladder" is the ladder provided at survival craft embarkation stations to permit safe access to survival craft after launching.
- .3 "Embarkation station" is the place from which a survival craft is boarded. An embarkation station may also serve as an assembly station, provided there is sufficient room, and the assembly station activities can safely take place there.
- .4 "Float-free launching" is that method of launching a survival craft whereby the craft is automatically released from a sinking craft and is ready for use.
- .5 "Free-fall launching" is that method of launching a survival craft whereby the craft with its complement of persons and equipment on board is released and allowed to fall into the sea without any restraining apparatus.

- .6 "Immersion suit" is a protective suit which reduces the body heat-loss of a person wearing it in cold water.
- .7 "Inflatable appliance" is an appliance which depends upon non-rigid, gas-filled chambers for buoyancy and which is normally kept uninflated until ready for use.
- .8 "Inflated appliance" is an appliance which depends upon non-rigid, gas-filled chambers for buoyancy and which is normally kept inflated and ready for use at all times.
- .9 "Launching appliance or arrangement" is a means of transferring a survival craft or rescue boat from its stowed position safely to the water.
- .10 "Marine evacuation system (MES)" is an appliance designed to rapidly transfer a large number of persons from an embarkation station by means of a passage to a floating platform for subsequent embarkation into associated survival craft or directly into associated survival craft.
- .11 "Novel life-saving appliance or arrangement" is a life-saving appliance or arrangement which embodies new features not fully covered by the provisions of this chapter but which provides an equal or higher standard of safety.
- .12 "Rescue boat" is a boat designed to assist and rescue persons in distress and to marshal survival craft.
- .13 "Retrieval" is the safe recovery of survivors.
- .14 "Retro-reflective material" is a material which reflects in the opposite direction a beam of light directed on it.
- .15 "Survival craft" is a craft capable of sustaining the lives of persons in distress from the time of abandoning the craft.
- .16 "Thermal protective aid" is a bag or suit of waterproof material with low thermal conductance.

8.2 Communications

8.2.1 Craft shall be provided with the following radio life-saving appliances:

- .1 at least three two-way VHF radiotelephone apparatus shall be provided on every passenger high-speed craft and on every cargo high-speed craft of 500 gross tonnage and upwards. Such apparatus shall conform to performance standards not inferior to those adopted by the Organization⁴⁹;
- .2 at least one search and rescue locating device shall be carried on each side of every passenger high-speed craft and every cargo high-speed craft of 500 gross tonnage and upwards. Such search and rescue locating device shall conform to the applicable performance standards not inferior to those adopted by the Organization⁵⁰. The search and rescue locating device shall be stowed in such locations that they can be rapidly placed in any one of the liferafts. Alternatively, one search and rescue locating device shall be stowed in each survival craft.
(TSFS 2023:58)

8.2.2 Craft shall be provided with the following on-board communications and alarm systems:

- .1 an emergency means comprising either fixed or portable equipment or both for two-way communications between emergency control stations, assembly and embarkation stations and strategic positions on board;
- .2 a general emergency alarm system complying with the requirements of paragraph 7.2.1 of the LSA Code to be used for summoning passengers and crew to assembly stations and to initiate the actions included in the muster list. The system shall be supplemented by a public address system complying with the requirements of paragraph 7.2.2 of the LSA Code, or by other suitable means of communication. The systems shall be operable from the operating compartment.

⁴⁹ Refer to the Recommendation on Performance Standards for Survival Craft Portable Two-Way VHF Radiotelephone Apparatus, adopted by the Organization by resolution A.809(19).

⁵⁰ Refer to the Recommendation on Performance Standards for Survival Craft Radar Transponders for Use in Search and Rescue Operations, adopted by the Organization by resolution MSC.247(83) (A.802(19)), as amended) and the Recommendation on Performance Standards for Survival Craft AIS Search and Rescue Transmitter (AIS SART), adopted by the Organization by resolution MSC.246(83).

8.2.3 Signalling equipment

8.2.3.1 All craft shall be provided with a portable daylight signalling lamp which is available for use in the operating compartment at all times and which is not dependent on the craft's main source of electrical power.

8.2.3.2 Craft shall be provided with not less than 12 rocket parachute flares, complying with the requirements of paragraph 3.1 of the LSA Code, stowed in or near the operating compartment.

8.3 Personal life-saving appliances

8.3.1 Where passengers or crew have access to exposed decks under normal operating conditions, at least one lifebuoy on each side of the craft capable of quick release from the control compartment and from a position at or near where it is stowed, shall be provided with a self-igniting light and a self-activating smoke signal. The positioning and securing arrangements of the self-activating smoke signal shall be such that it cannot be released or activated solely by the accelerations produced by collisions or groundings.

8.3.2 At least one lifebuoy shall be provided adjacent to each normal exit from the craft and on each open deck to which passengers and crew have access, subject to a minimum of two being installed.

8.3.3 Lifebuoys fitted adjacent to each normal exit from the craft shall be fitted with buoyant lines of at least 30 m in length.

8.3.4 Not less than half the total number of lifebuoys shall be fitted with self-igniting lights. However, the lifebuoys provided with self-igniting lights shall not include those provided with lines in accordance with 8.3.3.

8.3.5 A lifejacket complying with the requirements of paragraph 2.2.1 or 2.2.2 of the LSA Code be provided for every person on board the craft and, in addition:

- .1 a number of lifejackets suitable for children equal to at least 10% of the number of passengers on board shall be provided or such greater number as may be required to provide a lifejacket for each child;
- .2 every passenger craft shall carry lifejackets for not less than 5% of the total number of persons on board. These lifejackets shall be stowed in conspicuous places on deck or at assembly stations;
- .3 a sufficient number of lifejackets shall be carried for persons on watch and for use at remotely located survival craft and rescue boat stations; and

- .4 all lifejackets shall be fitted with a light, which complies with the requirements of paragraph 2.2.3 of the LSA Code.

8.3.6 Lifejackets shall be so placed as to be readily accessible and their positions shall be clearly indicated.

8.3.7 An immersion suit, of an appropriate size, complying with the requirements of paragraph 2.3 of the LSA Code shall be provided for every person assigned to crew the rescue boat.

8.3.8 An immersion suit or anti-exposure suit shall be provided for each member of the crew assigned, in the muster list, to duties in an MES party for embarking passengers into survival craft. These immersion suits or anti-exposure suits need not be required if the craft is constantly engaged on voyages in warm climates where, in the opinion of the Administration, such suits are unnecessary.

8.4 Muster list, emergency instructions and manuals

8.4.1 Clear instructions to be followed in the event of an emergency shall be provided for each person on board⁵¹.

8.4.2 Muster lists complying with the requirements of regulation III/37 of the Convention shall be exhibited in conspicuous places throughout the craft including the control compartment, engine-room and crew accommodation spaces.

8.4.3 Illustrations and instructions in appropriate languages shall be posted in public spaces and be conspicuously displayed at assembly stations, at other passenger spaces and near each seat to inform passengers of:

- .1 their assembly station;
- .2 the essential actions they must take in an emergency;
- .3 the method of donning lifejackets.

8.4.4 Every passenger craft shall have passenger assembly stations:

⁵¹ Refer to the Guidelines for passenger safety instructions on ro-ro passenger ships (MSC/Circ.681).

- .1 in the vicinity of, and which provide ready access for all the passengers to, the embarkation stations unless in the same location; and
- .2 which have ample room for the marshalling and instruction of passengers.

8.4.5 A training manual complying with the requirements of 18.2.3 shall be provided in each crew messroom and recreation room.

8.5 Operating instructions

8.5.1 Poster or signs shall be provided on or in the vicinity of survival craft and their launching controls and shall:

- .1 illustrate the purpose of controls and the procedures for operating the appliance and give relevant instructions and warnings;
- .2 be easily seen under emergency lighting conditions;
- .3 use symbols in accordance with the recommendations of the Organization⁵².

8.6 Survival craft stowage

8.6.1 Survival craft shall be securely stowed outside and as close as possible to the passenger accommodation and embarkation stations. The stowage shall be such that each survival craft can be safely launched in a simple manner and remain secured to the craft during and subsequent to the launching procedure. The length of the securing lines and the arrangements of the bowsing lines shall be such as to maintain the survival craft suitably positioned for embarkation. The Administrations may permit the use of adjustable securing and/or bowsing lines at exits where more than one survival craft is used. The securing arrangements for all securing and bowsing lines shall be of sufficient strength to hold the survival craft in position during the evacuation process.

⁵² Refer to Symbols related to Life-Saving Appliances and Arrangements, adopted by the Organization by resolution A.760(18), as amended by resolution MSC.82(70).

8.6.2 Survival craft shall be so stowed as to permit release from their securing arrangements at or near to their stowage position on the craft and from a position at or near to the operating compartment.

8.6.3 So far as is practicable, survival craft shall be distributed in such a manner that there is an equal capacity on both sides of the craft.

8.6.4 The launching procedure for inflatable liferafts shall, where practicable, initiate inflation. Where it is not practicable to provide automatic inflation of liferafts (for example, when the liferafts are associated with an MES), the arrangement shall be such that the craft can be evacuated within the time specified in 4.8.1.

8.6.5 Survival craft shall be capable of being launched and then boarded from the designated embarkation stations in all operational conditions and also in all conditions of flooding after receiving damage to the extent prescribed in chapter 2.

8.6.6 Survival craft launching stations shall be in such positions as to ensure safe launching having particular regard to clearance from the propeller or waterjet and steeply overhanging portions of the hull.

8.6.7 During preparation and launching, the survival craft and the area of water into which it is to be launched shall be adequately illuminated by the lighting supplied from the main and emergency sources of electrical power required by chapter 12.

8.6.8 Means shall be available to prevent any discharge of water on to survival craft when launched.

8.6.9 Each survival craft shall be stowed:

- .1 so that neither the survival craft nor its stowage arrangements will interfere with the operation of any other survival craft or rescue boat at any other launching station;
- .2 in a state of continuous readiness;
- .3 fully equipped; and
- .4 as far as practicable, in a secure and sheltered position and protected from damage by fire and explosion.

8.6.10 Every liferaft shall be stowed with its painter permanently attached to the craft and with a float free arrangement complying with the requirements of paragraph 4.1.6 of the LSA Code so that, as far as practicable, the liferaft floats free and, if inflatable, inflates automatically should the high speed craft sink.

8.6.11 Rescue boats shall be stowed:

- .1 in a state of continuous readiness for launching in not more than 5 min;
- .2 in a position suitable for launching and recovery; and
- .3 so that neither the rescue boat nor its stowage arrangements will interfere with the operation of survival craft at any other launching station.

8.6.12 Rescue boats and survival craft shall be secured and fastened to the deck so that they at least withstand the loads likely to arise due to a defined horizontal collision load for the actual craft and the vertical design load at the stowage position.

8.7 Survival craft and rescue boat embarkation and recovery arrangements

8.7.1 Embarkation stations shall be readily accessible from accommodation and work areas. If the designated assembly stations are other than the passenger spaces, the assembly stations shall be readily accessible from the passenger spaces, and the embarkation stations shall be readily accessible from the assembly stations.

8.7.2 Evacuation routes, exits and embarkation points shall comply with the requirements of 4.7.

8.7.3 Alleyways, stairways and exits giving access to the assembly and embarkation stations shall be adequately illuminated by lighting supplied from the main and emergency source of electrical power required by chapter 12.

8.7.4 Where davit-launched survival craft are not fitted, MES or equivalent means of evacuation shall be provided in order to avoid persons entering the water to board survival craft. Such MES or equivalent means of evacuation shall be so designed as to enable persons to board survival craft in all operational conditions and also in all conditions of flooding after receiving damage to the extent prescribed in chapter 2.

8.7.5 Subject to survival craft and rescue boat embarkation arrangements being effective within the environmental conditions in which the craft is permitted to operate and in all undamaged and prescribed damage conditions of trim and heel, where the freeboard between the intended embarkation position and the waterline is not more than 1.5 m, the Administration may accept a system where persons board liferafts directly.

8.7.6 Where an MES is provided for embarkation into survival craft on a category B craft, an alternative means of evacuating passengers and crew into survival craft on the same side of the craft in conditions up to and including the worst intended conditions is to be provided for use if the MES is lost or rendered unserviceable in the event of damage of longitudinal extent specified in 2.6.7.1.

8.7.7 Rescue boat embarkation arrangements shall be such that the rescue boat can be boarded and launched directly from the stowed position and recovered rapidly when loaded with its full complement of persons and equipment.

8.7.8 Launching systems for rescue boats on category B craft may be based on power supply from the craft's power supply under the following conditions:

- .1 the davit or crane shall be supplied with power from 2 sources in each independent engine room;
- .2 the davit or crane shall comply with the required launching, lowering and hoisting speeds when using only one power source; and
- .3 the davit or crane is not required to be activated from a position within the rescue boat.

8.7.9 On multihull craft with a small HL₁ angle of heel and trim, the design angles in paragraph 6.1 of the LSA Code may be changed from 20°/10° to the maximum angles calculated in accordance with annex 7, including heeling lever HL₂, HTL, HL₃ or HL₄.

8.7.10 Rescue boat davits or cranes may be designed for launching and recovering the boat with 3 persons only on the condition that an additional boarding arrangement is available on each side complying with 8.7.5.

8.7.11 A safety knife shall be provided at each MES embarkation station.

8.8 Line-throwing appliance

A line-throwing appliance complying with the requirements of paragraph 7.1 of the LSA Code shall be provided.

8.9 Operational readiness, maintenance and inspections

8.9.1 Operational readiness

Before the craft leaves port and at all times during the voyage, all life-saving appliances shall be in working order and ready for immediate use.

8.9.2 Maintenance

- .1 Instructions for on-board maintenance of life-saving appliances complying with the requirements of regulation III/36 of the Convention shall be provided and maintenance shall be carried out accordingly.
- .2 The Administration may accept, in lieu of the instructions required by .1, a shipboard planned maintenance programme which includes the requirements of regulation III/36 of the Convention.

8.9.3 Maintenance of falls

8.9.3.1 Falls used in launching shall be turned end for end at intervals of not more than 30 months and be renewed when necessary due to deterioration of the falls or at intervals of not more than five years, whichever is the earlier.

8.9.3.2 The Administration may accept in lieu of "end for ending" required in 8.9.3.1, periodic inspection of the falls and their renewal whenever necessary due to deterioration or at intervals of not more than four years, whichever is the earlier.

8.9.4 Spares and repair equipment

Spares and repair equipment shall be provided for life-saving appliances and their components which are subject to excessive wear or consumption and need to be replaced regularly.

8.9.5 Weekly inspection

The following tests and inspections shall be carried out weekly:

- .1 all survival craft, rescue boats and launching appliances shall be visually inspected to ensure that they are ready for use;
- .2 all engines in rescue boats shall be run ahead and astern for a total period of not less than 3 min provided the ambient temperature is above the minimum temperature required for starting and running the engine. During this period of time, it should be demonstrated that the gearbox and gearbox train are engaging satisfactorily. If the special characteristics of an outboard motor fitted to a rescue boat would not allow it to be run other than with its propeller submerged for a period of 3 min, it should be run for such period as prescribed in the manufacturer's handbook; and
- .3 the general emergency alarm system shall be tested.

8.9.6 Monthly inspections

Inspection of the life-saving appliances, including survival craft equipment shall be carried out monthly using the checklist required by regulation III/36.1 of the Convention to ensure that they are complete and in good order. A report of the inspection shall be entered in the log-book.

8.9.7 Servicing of inflatable liferafts, inflatable lifejackets, marine evacuation systems and inflated rescue boats

8.9.7.1 Every inflatable liferaft, inflatable lifejacket and MES shall be serviced:

- .1 at intervals not exceeding 12 months, provided where in any case this is impracticable, the Administration may extend this period by one month;
- .2 at an approved servicing station which is competent to service them, maintains proper servicing facilities and uses only properly trained personnel⁵³.

8.9.8 Rotational deployment of marine evacuation systems

In addition to or in conjunction with the servicing intervals of marine evacuation systems required by 8.9.7.1, each marine evacuation system shall be deployed from the craft on a rotational basis at intervals to be agreed by the Administration provided that each system is to be deployed at least once every six years.

8.9.9 An Administration which approves new and novel inflatable liferaft arrangements pursuant to 8.1 may allow for extended service intervals under the following conditions:

8.9.9.1 The new and novel liferaft arrangement shall maintain the same standard, as required by testing procedure, throughout the extended service intervals.

8.9.9.2 The liferaft system shall be checked on board by certified personnel according to paragraph 8.9.7.1.

8.9.9.3 Service at intervals not exceeding five years shall be carried out in accordance with recommendations of the Organization.

⁵³ Refer to the Recommendation on Conditions for the Approval of Servicing Stations for Inflatable Liferafts, adopted by the Organization by resolution A.761(18), as amended by resolution MSC.55(66).

8.9.10 All repairs and maintenance of inflated rescue boats shall be carried out in accordance with the manufacturer's instructions. Emergency repairs may be carried out on board the craft, however, permanent repairs shall be effected at an approved servicing station.

8.9.11 An Administration which permits extension of liferaft service intervals in accordance with 8.9.9 shall notify the Organization of such action in accordance with regulation I/5(b) of the Convention.

8.9.12 Periodic servicing of hydrostatic release units

Hydrostatic release units shall be serviced:

- .1 at intervals not exceeding 12 months, provided where in any case this is impracticable, the Administration may extend this period by one month;
- .2 at a servicing station which is competent to service them, maintains proper servicing facilities and uses only properly trained personnel.

8.9.13 Marking of stowage locations

Containers, brackets, racks and other similar stowage locations for life-saving equipment, shall be marked with symbols in accordance with the recommendations of the Organization, indicating the devices stowed in that location for that purpose. If more than one device is stowed in that location, the number of devices shall also be indicated.

8.9.14 Periodic servicing of launching appliances

8.9.14.1⁵⁴ Launching appliances:

- .1 shall be serviced at recommended intervals in accordance with instructions for on-board maintenance as required by regulation III/36 of the Convention;
- .2 shall be subject to a thorough examination at the annual surveys required by paragraph 1.5.1.3; and
- .3 shall upon completion of the examination in .2 be subjected to a dynamic test of the winch brake at maximum lowering speed. The load to be applied shall be the mass of the survival craft or rescue boat without persons on board, except that, at intervals not exceeding

⁵⁴ Noterna 140 och 141 i MSC 82/24/Add.1 anges felaktigt till 8.9.14.2 resp. 8.9.14.3. Ska vara 8.9.14.1.2 resp. 8.9.14.1.3.

five years, the test shall be carried out with a proof load equal to 1.1 times the weight of the survival craft or rescue boat and its full complement of persons and equipment.

8.10 Survival craft and rescue boats

8.10.1 All craft shall carry:

- .1 survival craft with sufficient capacity as will accommodate not less than 100% of the total number of persons the craft is certified to carry, subject to a minimum of two such survival craft being carried;
- .2 in addition, survival craft with sufficient aggregate capacity to accommodate not less than 10% of the total number of persons the craft is certified to carry;
- .3 sufficient survival craft to accommodate the total number of persons the craft is certified to carry, even in the event that all the survival craft to one side of the craft centre-line and within the longitudinal extent of damage defined in 2.6.7.1 are considered lost or rendered unserviceable;
- .4 at least one rescue boat for retrieving persons from the water, but not less than one such boat on each side when the craft is certified to carry more than 450 passengers;
- .5 notwithstanding the provision of .4 above, craft shall carry sufficient rescue boats to ensure that, in providing for abandonment by the total number of persons the craft is certified to carry:
 - .5.1 not more than nine of the liferafts provided in accordance with 8.10.1.1 are marshalled by each rescue boat; or
 - .5.2 if the Administration is satisfied that the rescue boats are capable of towing a pair of such liferafts simultaneously, not more than 12 of the liferafts provided in accordance with 8.10.1.1 are marshalled by each rescue boat; and
 - .5.3 the craft can be evacuated within the time specified in 4.8.
- .6 craft of less than 30 m in length may be exempted from carrying a rescue boat, provided the craft meets all of the following requirements:
 - .6.1 the craft is arranged to allow a helpless person to be recovered from the water in a horizontal or near-horizontal body position;
 - .6.2 recovery of the helpless person can be observed from the navigating bridge; and
 - .6.3 the craft is sufficiently manoeuvrable to close in and recover persons in the worst intended conditions.
(TSFS 2023:58)

8.10.2 Where the Administration considers it appropriate, in view of the sheltered nature of the voyages and the suitable climatic conditions of the intended area of operations, the Administration may permit the use of open reversible inflatable liferafts complying with annex 11 on category A craft as an alternative to liferafts complying with paragraph 4.2 or 4.3 of the LSA Code.

8.11 Helicopter pick-up areas

8.11.1 Craft operating on voyages having a duration of 2 h or more between each port of call shall be provided with a helicopter pick-up area approved by the Administration having regard to the recommendations adopted by the Organization⁵⁵.

⁵⁵ Refer to the International Aeronautical and Maritime Search and Rescue Manual (IAMSAR) adopted by the Organization by resolution A.894(21), as amended.

CHAPTER 9

Machinery

PART A - GENERAL

9.1 General

9.1.1 The machinery, associated piping systems and fittings relating to main machinery and auxiliary power units shall be of a design and construction adequate for the service for which they are intended and shall be so installed and protected as to reduce to a minimum any danger to persons on board, due regard being paid to moving parts, hot surfaces and other hazards. The design shall have regard to materials used in construction, the purpose for which the equipment is intended, the working conditions to which it will be subjected and the environmental conditions on board.

9.1.2 All surfaces with temperatures exceeding 220°C where impingement of flammable liquids may occur as a result of a system failure shall be insulated. The insulation shall be impervious to flammable liquids and vapours.

9.1.3 Special consideration shall be given to the reliability of single essential propulsion components and a separate source of propulsion power sufficient to give the craft a navigable speed, especially in the case of unconventional arrangements, may be required.

9.1.4 Means shall be provided whereby normal operation of propulsion machinery can be sustained or restored even though one of the essential auxiliaries becomes inoperative. Special consideration shall be given to the malfunctioning of:

- .1 a generating set which serves as a main source of electrical power;
- .2 the fuel oil supply systems for engines;
- .3 the sources of lubricating oil pressure;
- .4 the sources of water pressure;
- .5 an air compressor and receiver for starting or control purposes;
- .6 the hydraulic, pneumatic or electrical means for control in main propulsion machinery, including controllable-pitch propellers.

However, having regard to overall safety considerations, a partial reduction in propulsion capability from normal operation may be accepted.

9.1.5 Means shall be provided to ensure that the machinery can be brought into operation from the dead craft condition without external aid.

9.1.6 All parts of machinery, hydraulic, pneumatic and other systems and their associated fittings which are under internal pressure shall be subjected to appropriate tests including a pressure test before being put into service for the first time.

9.1.7 Provision shall be made to facilitate cleaning, inspection and maintenance of main propulsion and auxiliary machinery including boilers and pressure vessels.

9.1.8 The reliability of machinery installed in the craft shall be adequate for its intended purpose.

9.1.9 The Administration may accept machinery which does not show detailed compliance with the Code where it has been used satisfactorily in a similar application, provided that it is satisfied:

- .1 that the design, construction, testing, installation and prescribed maintenance are together adequate for its use in a marine environment; and
- .2 that an equivalent level of safety will be achieved.

9.1.10 A failure mode and effect analysis shall include machinery systems and their associated controls.

9.1.11 Such information as is necessary to ensure that machinery can be installed correctly regarding such factors as operating conditions and limitations shall be made available by the manufacturers.

9.1.12 Main propulsion machinery and all auxiliary machinery essential to the propulsion and the safety of the craft shall, as fitted in the craft, be designed to operate when the craft is upright and when inclined at any angle of list up to and including 15° either way under static conditions and 22.5° under dynamic conditions (rolling) either way and simultaneously inclined by dynamically (pitching) 7.5° by bow or stern. The Administration may permit deviation from these angles, taking into consideration the type, size and service conditions of the craft.

9.1.13 All boilers, and pressure vessels and associated piping systems shall be of a design and construction adequate for the purpose intended and shall be so installed and protected as to minimise danger to persons on board. In particular, attention shall be paid to the materials used in the construction and the working pressures and temperatures at which the item

will operate and the need to provide an adequate margin of safety over the stresses normally produced in service. Every boiler, pressure vessel and associated piping systems shall be fitted with adequate means to prevent over-pressures in service and be subjected to a hydraulic test before being put into service, and where appropriate at subsequent specified intervals, to a pressure suitably in excess of the working pressure.

9.1.14 Arrangements shall be provided to ensure that, in the event of failure in any liquid cooling system, it is rapidly detected and alarmed (visual and audible) and means instituted to minimise the effects of such failures on machinery serviced by the system.

9.2 Engine (general)

9.2.1 The engines shall be fitted with adequate safety monitoring and control devices in respect of speed, temperature, pressure and other operational functions. Control of the machinery shall be from the craft's operating compartment. Category B craft and cargo craft shall be provided with additional machinery controls in or close to the machinery space. The machinery installation shall be suitable for operation as in an unmanned machinery space⁵⁶, including automatic fire detection system, bilge alarm system, remote machinery instrumentation and alarm system. Where the space is continuously manned, this requirement may be varied in accordance with the requirements of the Administration.

9.2.2 The engines shall be protected against overspeed, loss of lubricating oil pressure, loss of cooling medium, high temperature, malfunction of moving parts and overload. Safety devices shall not cause complete engine shutdown without prior warning, except in cases where there is a risk of complete breakdown or explosion. Such safety devices shall be capable of being tested.

9.2.3 At least two independent means of stopping the engines quickly from the operating compartment under any operating conditions shall be available. Duplication of the actuator fitted to the engine shall not be required.

9.2.4 The major components of the engine shall have adequate strength to withstand the thermal and dynamic conditions of normal operation. The engine shall not be damaged by a limited operation at a speed or at temperatures exceeding the normal values but within the range of the protective devices.

⁵⁶ Refer to part E of chapter II-1 of the Convention.

9.2.5 The design of the engine shall be such as to minimise the risk of fire or explosion and to enable compliance with the fire precaution requirements of chapter 7.

9.2.6 Provision shall be made to drain all excess fuel and oil to a safe position so as to avoid a fire hazard.

9.2.7 Provision shall be made to ensure that, whenever practical, the failure of systems driven by the engine shall not unduly affect the integrity of the major components.

9.2.8 The ventilation arrangements in the machinery spaces shall be adequate under all envisaged operating conditions. Where appropriate, arrangements shall ensure that enclosed engine compartments are forcibly ventilated to the atmosphere before the engine can be started.

9.2.9 Any engines shall be so installed as to avoid excessive vibration within the craft.

9.3 Gas turbines

9.3.1 Gas turbines shall be designed to operate in the marine environment and shall be free from surge or dangerous instability throughout its operating range up to the maximum steady speed approved for use. The turbine installation shall be arranged to ensure that the turbine cannot be continuously operated within any speed range where excessive vibration, stalling, or surging may be encountered.

9.3.2 The gas turbines shall be designed and installed such that any reasonably probable shedding of compressor or turbine blades will not endanger the craft, other machinery, occupants of the craft or any other persons.

9.3.3 Requirements of 9.2.6 shall apply to gas turbines in respect of fuel which might reach the interior of the jet pipe or exhaust system after a false start or after stopping.

9.3.4 Turbines shall be safeguarded as far as practicable against the possibility of damage by ingestion of contaminants from the operating environment. Information regarding the recommended maximum concentration of contamination shall be made available. Provision shall be made for preventing the accumulation of salt deposits on the compressors and turbines and, if necessary, for preventing the air intake from icing.

9.3.5 In the event of a failure of a shaft or weak link, the broken end shall not hazard the occupants of the craft, either directly or by damaging the craft or its systems. Where necessary, guards may be fitted to achieve compliance with these requirements.

9.3.6 Each engine shall be provided with an emergency overspeed shutdown device connected, where possible, directly to each rotor shaft.

9.3.7 Where an acoustic enclosure is fitted which completely surrounds the gas generator and the high pressure oil pipes, a fire detection and extinguishing system shall be provided for the acoustic enclosure.

9.3.8 Details of the manufacturers' proposed automatic safety devices to guard against hazardous conditions arising in the event of malfunction in the turbine installation shall be provided together with the failure mode and effect analysis.

9.3.9 The manufacturers shall demonstrate the soundness of the casings. Intercoolers and heat exchangers shall be hydraulically tested on each side separately.

9.4 Diesel engines for main propulsion and essential auxiliaries

9.4.1 Any main diesel propulsion system shall have satisfactory torsional vibration and other vibrational characteristics verified by individual and combined torsional and other vibration analyses for the system and its components from power unit through to propulsor.

9.4.2 All external high-pressure fuel delivery lines between the high-pressure fuel pumps and fuel nozzles shall be protected with a jacketed tubing system capable of containing fuel from a high-pressure line failure. The jacketed tubing system shall include a means for collection of leakages and arrangements shall be provided for an alarm to be given of a fuel line failure.

9.4.3 Engines of a cylinder diameter of 200 mm or a crankcase volume of 0.6 m³ and above shall be provided with crankcase explosion relief valves of an approved type with sufficient relief area. The relief valves shall be arranged with means to ensure that discharge from them is directed so as to minimise the possibility of injury to personnel.

9.4.4 The lubrication system and arrangements shall be efficient at all running speeds, due consideration being given to the need to maintain suction and avoid the spillage of oil in all conditions of list and trim and degree of motion of the craft.

9.4.5 Arrangements shall be provided to ensure that visual and audible alarms are activated in the event of either lubricating oil pressure or lubricating oil level falling below a safe level, considering the rate of circulation of oil in the engine. Such events shall also cause automatic reduction of engine speed to a safe level, but automatic shutdown shall only

be activated by conditions leading to a complete breakdown, fire or explosion.

9.4.6 Where diesel engines are arranged to be started, reversed or controlled by compressed air, the arrangement of the air compressor, air receiver and air starting system shall be such as to minimise the risk of fire or explosion.

9.5 Transmissions

9.5.1 The transmission shall be of adequate strength and stiffness to enable it to withstand the most adverse combination of the loads expected in service without exceeding acceptable stress levels for the material concerned.

9.5.2 The design of shafting, bearings and mounts shall be such that hazardous whirling and excessive vibration could not occur at any speed up to 105% of the shaft speed attained at the designed overspeed trip setting of the prime mover.

9.5.3 The strength and fabrication of the transmission shall be such that the probability of hazardous fatigue failure under the action of the repeated loads of variable magnitude expected in service is extremely remote throughout its operational life. Compliance shall be demonstrated by suitably conducted tests, and by designing for sufficiently low stress levels, combined with the use of fatigue resistant materials and suitable detail design. Torsional vibration or oscillation likely to cause failure may be acceptable if it occurs at transmission speeds which would not be used in normal craft operation, and it is recorded in the craft operating manual as a limitation.

9.5.4 Where a clutch is fitted in the transmission, normal engagement of the clutch shall not cause excessive stresses in the transmission or driven items. Inadvertent operation of any clutch shall not produce dangerously high stresses in the transmission or driven item.

9.5.5 Provision shall be made such that a failure in any part of the transmission, or of a driven component, will not cause damage which might hazard the craft or its occupants.

9.5.6 Where failure of lubricating fluid supply or loss of lubricating fluid pressure could lead to hazardous conditions, provision shall be made to enable such failure to be indicated to the operating crew in adequate time to enable them as far as practicable to take the appropriate action before the hazardous condition arises.

9.6 Propulsion and lift devices

9.6.1 The requirements of this section are based on the premise that:

- .1 Propulsion arrangements and lift arrangements may be provided by separate devices, or be integrated into a single propulsion and lift device. Propulsion devices may be air, or water propellers or water jets and the requirements apply to all types of craft.
- .2 Propulsion devices are those which directly provide the propulsive thrust and include machinery items and any associated ducts, vanes, scoops and nozzles, the primary function of which is to contribute to the propulsive thrust.
- .3 The lift devices, for the purposes of this section, are those items of machinery which directly raise the pressure of the air and move it for the primary purpose of providing lifting force for an air-cushion vehicle.

9.6.2 The propulsion and lift devices shall be of adequate strength and stiffness. The design data, calculations and trials, where necessary, shall establish the ability of the device to withstand the loads which can arise during the operations for which the craft is to be certificated, so that the possibility of catastrophic failure is extremely remote.

9.6.3 The design of propulsion and lift devices shall pay due regard to the effects of allowable corrosion, electrolytic action between different metals, erosion or cavitation which may result from operation in environments in which they are subjected to spray, debris, salt, sand, icing, etc.

9.6.4 The design data and testing of propulsion and lift devices shall pay due regard, as appropriate, to any pressure which could be developed as a result of a duct blockage, to steady and cyclic loadings, to loadings due to external forces and to the use of the devices in manoeuvring and reversing and to the axial location of rotating parts.

9.6.5 Appropriate arrangements shall be made to ensure that:

- .1 ingestion of debris or foreign matter is minimised;
- .2 the possibility of injury to personnel from shafting or rotating parts is minimised; and
- .3 where necessary, inspection and removal of debris can be carried out safely in service.

PART B - REQUIREMENTS FOR PASSENGER CRAFT

9.7 Independent means of propulsion for category B craft

Category B craft shall be provided with at least two independent means of propulsion so that the failure of one engine or its support systems would not cause the failure of the other engine or engine systems and with additional machinery controls in or close to the machinery space.

9.8 Means for return to a port of refuge for category B craft

Category B craft shall be capable of maintaining the essential machinery and control so that, in the event of a fire or other casualties in any one compartment on board, the craft can return to a port of refuge under its own power.

PART C - REQUIREMENTS FOR CARGO CRAFT

9.9 Essential machinery and control

Cargo craft shall be capable of maintaining the essential machinery and control in the event of a fire or other casualties in any one compartment on board. The craft need not be able to return to a place of refuge under its own power.

CHAPTER 10

Auxiliary Systems

PART A - GENERAL

10.1 General

10.1.1 Fluid systems shall be constructed and arranged so as to assure a safe and adequate flow of fluid at a prescribed flow rate and pressure under all conditions of craft operation. The probability of a failure or a leakage in any one fluid system, causing damage to the electrical system, a fire or an explosion hazard shall be extremely remote. Attention shall be directed to the avoidance of impingement of flammable liquid on hot surfaces in the event of leakage or fracture of the pipe.

10.1.2 The maximum allowable working pressure in any part of the fluid system shall not be greater than the design pressure, having regard to the allowable stresses in the materials. Where the maximum allowable working pressure of a system component, such as a valve or a fitting, is less than that computed for the pipe or tubing, the system pressure shall be limited to the lowest of the component maximum allowable working pressures. Every system which may be exposed to pressures higher than the system's maximum allowable working pressure shall be safeguarded by appropriate relief devices.

10.1.3 Tanks and piping shall be pressure-tested to a pressure that will assure a safety margin in excess of the working pressure of the item. The test on any storage tank or reservoir shall take into account any possible static head in the overflow condition and the dynamic forces arising from craft motions.

10.1.4 Materials used in piping systems shall be compatible with the fluid conveyed and selected giving due regard to the risk of fire. Non-metallic piping material may be permitted in certain systems provided the integrity of the hull and watertight decks and bulkheads is maintained⁵⁷.

⁵⁷ Refer to the Guidelines for the Application of Plastic Pipes on Ships, adopted by the Organization by resolution A.753(18).

10.2 Arrangement of oil fuel, lubricating oil and other flammable oil

10.2.1 The provisions of 7.1.2.2 apply to the use of oil as fuel.

10.2.2 Oil fuel, lubricating oil and other flammable oil lines shall be screened or otherwise suitably protected to avoid, as far as practicable, oil spray or oil leakages onto hot surfaces, into machinery air intakes or other sources of ignition. The number of joints in such piping systems shall be kept to a minimum. Flexible pipes carrying flammable liquids shall be of an approved type⁵⁸.

10.2.3 Fuel oil, lubricating oils and other flammable oils shall not be carried forward of public spaces and crew accommodation.

Oil fuel arrangements

10.2.4 In a craft in which oil fuel is used, the arrangements for the storage, distribution and utilisation of the oil fuel shall be such as to ensure the safety of the craft and persons on board and shall at least comply with the following provisions.

10.2.4.1 As far as practicable, all parts of the oil fuel system containing heated oil under pressure exceeding 0.18 N/mm² shall not be placed in a concealed position such that defects and leakage cannot readily be observed. The machinery spaces in way of such parts of the oil fuel system shall be adequately illuminated.

10.2.4.2 The ventilation of machinery spaces shall be sufficient under all normal conditions to prevent accumulation of oil vapour.

10.2.4.3 Location of fuel tanks shall be in accordance with 7.5.2.

10.2.4.4 No oil fuel tank shall be situated where spillage or leakage therefrom can constitute a hazard by falling on heated surfaces. Reference is made to the fire safety requirements in 7.5.

10.2.4.5 Oil fuel pipes shall be fitted with cocks or valves in accordance with 7.5.3.

10.2.4.6 Every fuel tank shall, where necessary, be provided with savealls or gutters to catch any fuel which may leak from such tanks.

⁵⁸ Refer to the Guidelines to Minimize Leakages from Flammable Liquid Systems for Improving Reliability and Reducing Risk of Fire (MSC/Circ.647).

10.2.4.7 Safe and efficient means of ascertaining the amount of oil fuel contained in any oil fuel tank shall be provided.

10.2.4.7.1 Where surrounding pipes are used, they shall not terminate in any space where the risk of ignition of spillage from the sounding pipe might arise. In particular, they shall not terminate in public spaces, crew accommodation or machinery spaces. Terminations shall be provided with a suitable means of closure and provision to prevent spillage during refuelling operations.

10.2.4.7.2 Other oil-level gauges may be used in place of sounding pipes. Such means are subject to the following conditions:

- .1 In passenger craft, such means shall not require penetration below the top of the tank and their failure or overfilling of the tanks will not permit release of fuel.
- .2 The use of cylindrical gauge glasses shall be prohibited. In cargo craft, the Administration may permit the use of oil-level gauges with flat glasses and self-closing valves between the gauges and fuel tanks. Such other means shall be acceptable to the Administration and shall be maintained in the proper condition to ensure their continued accurate functioning in service.

10.2.4.8 Provision shall be made to prevent overpressure in any oil tank or in any part of the fuel system, including the bunkering pipes and any filling pipes served by on-board pumps. Any relief valves and air or overflow pipes shall discharge to a safe position where there is no risk of fire or explosion from the emergence of oils and vapour, shall not lead into crew spaces, passenger spaces, special category spaces, ro-ro spaces (other than open ro-ro spaces), machinery spaces or similar spaces. For fuel of flashpoint less than 43°C such valves and pipes, shall terminate with flame arresters in accordance with the standards developed by the Organization⁵⁹.

10.2.4.9 Oil fuel pipes and their valves and fittings shall be of steel or other approved material, except that restricted use of flexible pipes shall be permissible in positions where the Administration is satisfied that they are necessary⁶⁰. Such flexible pipes and end attachments shall be approved fire-resisting materials of adequate strength and shall be constructed to the satisfaction of the Administration.

⁵⁹ Refer to the Revised Standards for the Design, Testing and Locating of Devices to Prevent the Passage of Flame into Cargo Tanks in Tankers (MSC/Circ.677).

⁶⁰ Refer to recommendations published by the International Organization for Standardization, in particular, Publications ISO 15540:1999 on *Test methods for fire resistance of hose assemblies* and ISO 15541:1999 on *Requirements for the test bench of fire resistance of hose assemblies*.

Lubricating oil arrangements

10.2.5 The arrangements for the storage, distribution and utilisation of oil used in pressure lubrication systems shall be such as to ensure the safety of the craft and persons on board. The arrangements made in machinery spaces and, whenever practicable, in auxiliary machinery spaces shall at least comply with the provisions of 10.2.4.1 and 10.2.4.4 to 10.2.4.8 except that:

- .1 this does not preclude the use of sight-flow glasses in lubricating systems provided they are shown by test to have a suitable degree of fire resistance; and
- .2 sounding pipes may be permitted in machinery spaces if fitted with appropriate means of closure; and
- .3 lubricating oil storage tanks with a capacity of less than 500 l may be permitted without remote operated valves as required in 10.2.4.5.

Arrangements for other flammable oils

10.2.6 The arrangements for storage, distribution and utilisation of other flammable oil employed under pressure in power transmission systems, control and activating systems and heating systems shall be such as to ensure the safety of the craft and persons on board. In locations where means of ignition are present, such arrangements shall at least comply with the provisions of 10.2.4.4 and 10.2.4.7 and with the provisions of 10.2.4.8 and 10.2.4.9 in respect of strength and construction.

Arrangement within machinery spaces

10.2.7 In addition to the requirements of 10.2.1 to 10.2.6, the oil fuel and lubricating oil systems shall comply with the following:

- .1 Where daily service fuel tanks are filled automatically or by remote control, means shall be provided to prevent overflow spillages.
- .2 Other equipment which treats flammable liquids automatically, such as oil fuel purifiers, which, whenever practicable, should shall be installed in a special space reserved for purifiers and their heaters, shall have arrangements to prevent overflow spillages.
- .3 Where daily service oil fuel tanks or settling tanks are fitted with heating arrangements, a high-temperature alarm shall be provided if the flashpoint of the oil can be reached due to failure of the thermostatic control.

10.3 Bilge pumping and drainage systems

10.3.1 Arrangements shall be made for draining any watertight compartment other than the compartments intended for permanent storage of liquid. Where, in relation to particular compartments, drainage is not considered necessary, drainage arrangements may be omitted, but it shall be demonstrated that the safety of the craft will not be impaired.

10.3.2 Bilge pumping arrangements shall be provided to allow every watertight compartment other than those intended for permanent storage of liquid to be drained. The capacity or position of any such compartment shall be such that flooding thereof could not affect the safety of the craft.

10.3.3 The bilge pumping system shall be capable of operation under all possible values of list and trim after the craft has sustained the postulated damage in 2.6.6 to 2.6.10. The bilge pumping system shall be so designed as to prevent water flowing from one compartment to another. The necessary valves for controlling the bilge suctions shall be capable of being operated from above the datum. All distribution boxes and manually operated valves in connection with the bilge pumping arrangements shall be in positions which are accessible under ordinary circumstances. The spindles of manually operated valves shall be easily accessible and all valves shall be clearly marked.

10.3.4 The power operated self-priming bilge pumps may be used for other duties such as fire fighting or general service but not for pumping fuel or other flammable liquids.

10.3.5 Each power bilge pump shall be capable of pumping water through the required bilge pipe at a speed of not less than 2 m/s.

10.3.6 The diameter (d) of the bilge main shall be calculated according to the following formula, except that the actual internal diameter of the bilge main may be rounded off to the nearest size of a recognized standard:

$$d = 25 + 1.68(L(B + D))^{0.5}$$

where :

d is the internal diameter of the bilge main (mm);

L is the length of the craft (m) as defined in chapter 1;

B is, for monohull craft, the breadth of the craft (m) as defined in chapter 1 and, for multi-hull craft, the breadth of a hull at or below the design waterline (m); and

D is the moulded depth of the craft to the datum (m).

10.3.7 Internal diameters of suction branches shall meet the requirements of the Administration but shall not be less than 25 mm. Suction branches shall be fitted with effective strainers.

10.3.8 An emergency bilge suction shall be provided for each machinery space containing a propulsion prime mover. This suction shall be led to the largest available power pump other than a bilge pump, propulsion or oil pump. Emergency bilge suction shall be provided for craft with common bilge pumping systems according to 10.3.6 and for craft with individual bilge pumps according to 10.3.13.

10.3.9 The spindles of the sea inlet valves shall extend well above the machinery space floor plates.

10.3.10 All bilge suction piping up to the connection to the pumps shall be independent of other piping.

10.3.11 Spaces situated above the water level in the worst anticipated damage conditions may be drained directly overboard through scuppers fitted with nonreturn valves.

10.3.12 Any unattended space for which bilge pumping arrangements are required shall be provided with a bilge alarm.

10.3.13 For craft with individual bilge pumps, the total capacity Q of the bilge pumps for each hull shall not be less than 2.4 times the capacity of the pump defined in 10.3.5 and 10.3.6.

10.3.14 In bilge pumping arrangements where a bilge main is not provided, then, with the exception of the spaces forward of public spaces and crew accommodation, at least one fixed submersible pump shall be provided for each space. In addition, at least one portable pump shall be provided supplied from the emergency supply, if electric, for use on individual spaces. The capacity of each submersible pump Q_n shall not be less than:

$$Q_n = Q/(N - 1) \text{ tonnes/h with a minimum of 8 tonnes/h}$$

where :

N = number of submersible pumps

Q = total capacity as defined in 10.3.13.

10.3.15 Nonreturn valves shall be fitted in the following components:

- .1 bilge valve distribution manifolds;
- .2 bilge suction hose connections where fitted directly to the pump or to the main bilge suction pipe; and
- .3 direct bilge suction pipes and bilge pump connections to main bilge suction pipe.

10.4 Ballast systems

10.4.1 Water ballast shall not in general be carried in tanks intended for oil fuel. In craft in which it is not practicable to avoid putting water in oil fuel tanks, oily-water separating equipment shall be fitted, or other alternative means such as discharge to shore facilities shall be provided for disposing of the oily-water ballast. The provisions of this paragraph are without prejudice to the provisions of the International Convention for the Prevention of Pollution from Ships in force.

10.4.2 Where a fuel-transfer system is used for ballast purposes, the system shall be isolated from any water ballast system and meet the requirements for fuel systems and the International Convention for the Prevention of Pollution from Ships in force.

10.5 Cooling systems

The cooling arrangements provided shall be adequate to maintain all lubricating and hydraulic fluid temperatures within the manufacturers' recommended limits during all operations for which the craft is to be certificated.

10.6 Engine air intake systems

Arrangements shall provide sufficient air to the engine and shall give adequate protection against damage, as distinct from deterioration, due to ingress of foreign matter.

10.7 Ventilation systems

Machinery spaces shall be adequately ventilated so as to ensure that when machinery therein is operating at full power in all weather conditions, including heavy weather, an adequate supply of air is maintained to the spaces for the safety and comfort of personnel and the operation of the machinery. Auxiliary machinery spaces shall be adequately ventilated appropriate for the purpose of those spaces. The ventilation arrangements

shall be adequate to ensure that the safe operation of the craft is not put at risk.

10.8 Exhaust systems

10.8.1 All engine exhaust systems shall be adequate to assure the correct functioning of the machinery and that safe operation of the craft is not put at risk.

10.8.2 Exhaust systems shall be so arranged as to minimise the intake of exhaust gases into manned spaces, air-conditioning systems, and engine intakes. Exhaust systems shall not discharge into air-cushion intakes.

10.8.3 Pipes through which exhaust gases are discharged through the hull in the vicinity of the waterline shall be fitted with erosion-/corrosion-resistant shut-off flaps or other devices on the shell or pipe end and acceptable arrangements made to prevent water flooding the space or entering the engine exhaust manifold.

10.8.4 Gas turbine engine exhausts shall be arranged so that hot exhaust gases are directed away from areas to which personnel have access, either on board the craft or in the vicinity of the craft when berthed.

PART B - REQUIREMENTS FOR PASSENGER CRAFT

10.9 Bilge pumping and drainage systems

10.9.1 For Category B craft at least three and for Category A craft at least two power bilge pumps shall be fitted connected to the bilge main, one of which may be driven by the propulsion machinery. Alternatively, the arrangement may be in accordance with the requirements of 10.3.14.

10.9.2 The arrangements shall be such that at least one power bilge pump shall be available for use in all flooding conditions which the craft is required to withstand as follows:

- .1 one of the required bilge pumps shall be an emergency pump of a reliable submersible type having an emergency source of power; or
- .2 the bilge pumps and their sources of power shall be so distributed throughout the length of the craft that at least one pump in an undamaged compartment will be available.

10.9.3 On multihull craft, each hull shall be provided with at least two bilge pumps.

10.9.4 Distribution boxes, cocks and valves in connection with the bilge pumping system shall be so arranged that, in the event of flooding, one of the bilge pumps may be operative in any compartment. In addition, damage to a pump or its pipe connecting to the bilge main shall not put the bilge system out of action. When, in addition to the main bilge pumping system, an emergency bilge pumping system is provided, it shall be independent of the main system and so arranged that a pump is capable of operating in any compartment under flooding conditions as specified in 10.3.3. In that case only the valves necessary for the operation of the emergency system need be capable of being operated from above the datum.

10.9.5 All cocks and valves referred to in 10.9.4 which can be operated from above the datum shall have their controls at their place of operation clearly marked and shall be provided with means to indicate whether they are open or closed.

PART C - REQUIREMENTS FOR CARGO CRAFT

10.10 Bilge pumping systems

10.10.1 At least two power pumps connected to the main bilge system shall be provided, one of which may be driven by the propulsion machinery. If the Administration is satisfied that the safety of the craft is not impaired, bilge pumping arrangements may be dispensed with in particular compartments. Alternatively, the arrangement may be in accordance with the requirements of 10.3.14.

10.10.2 On multihull craft each hull shall be provided with at least two power pumps, unless a bilge pump in one hull is capable of pumping bilge in the other hull. At least one pump in each hull shall be an independent power pump.

CHAPTER 11

Remote Control, Alarm and Safety Systems

11.1 Definitions

11.1.1 "Remote control systems" comprise all equipment necessary to operate units from a control position where the operator cannot directly observe the effect of his actions.

11.1.2 "Back-up control systems" comprise all equipment necessary to maintain control of essential functions required for the craft's safe operation when the main control systems have failed or malfunctioned.

11.2 General

11.2.1 Failure of any remote or automatic control systems shall initiate an audible and visual alarm and shall not prevent normal manual control.

11.2.2 Manoeuvring and emergency controls shall permit the operating crew to perform the duties for which they are responsible in correct manner without difficulty, fatigue or excessive concentration.

11.2.3 Where control of propulsion or manoeuvring is provided at stations adjacent to but outside the operating compartment, the transfer of control shall only be effected from the station which takes charge of control. Two-way voice communication shall be provided between all stations from which control functions may be exercised and between each such station and the look-out position. Failure of the operating control system or of transfer of control shall bring the craft to low speed without hazarding passengers or the craft.

11.2.4 For category B and cargo craft, remote control systems for propulsion machinery and directional control shall be equipped with back-up systems controllable from the operating compartment. For cargo craft, instead of a back-up system described above, a back-up system controllable from an engine control space such as an engine control room outside the operating compartment, is acceptable.

11.3 Emergency controls

11.3.1 In all craft, the station or stations in the operating compartment from which control of craft manoeuvring and/or of its main machinery is exercised shall be provided, within easy reach of the crew member at that station, with controls for use in an emergency to:

- .1 activate fixed fire-extinguishing systems;
- .2 close ventilation openings and stop ventilating machinery supplying spaces covered by fixed fire-extinguishing systems, if not incorporated in .1;
- .3 shut off fuel supplies to machinery in main and auxiliary machinery spaces;
- .4 disconnect all electrical power sources from the normal power distribution system (the operating control shall be guarded to reduce the risk of inadvertent or careless operation); and
- .5 stop main engine(s) and auxiliary machinery.

11.3.2 Where control of propulsion and manoeuvring is provided at stations outside the operating compartment, such stations shall have direct communication with the operating compartment which shall be a continuously manned control station.

11.3.3 In addition, for category B craft control of propulsion and manoeuvring as well as emergency functions referred to in 11.3.1 shall be provided at one or more stations outside the operating compartment. Such stations shall have direct communication with the operating compartment which shall be a continuously manned control station.

11.4 Alarm system

11.4.1 Alarm systems shall be provided which announce at the craft's control position, by visual and audible means, malfunctions or unsafe conditions. Alarms shall be maintained until they are accepted and the visual indications of individual alarms shall remain until the fault has been corrected, when the alarm shall automatically reset to the normal operating condition. If an alarm has been accepted and a second fault occurs before the first is rectified, the audible and visual alarms shall operate again. Alarm systems shall incorporate a test facility.

11.4.1.1 Emergency alarms giving indication of conditions requiring immediate action shall be distinctive and in full view of crew members in the operating compartment, and shall be provided for the following:

- .1 activation of a fire-detection system;
- .2 total loss of normal electrical supply;
- .3 overspeed of main engines;
- .4 thermal runaway of any permanently installed nickel-cadmium battery.

11.4.1.2 Alarms with a visual display distinct from that of alarms referred to in 11.4.1.1 shall indicate conditions requiring action to prevent degradation to an unsafe condition. These shall be provided for at least the following:

- .1 exceeding the limiting value of any craft, machinery or system parameter other than engine overspeed;
- .2 failure of normal power supply to powered directional or trim control devices;
- .3 operation of any automatic bilge pump;
- .4 detection of bilge water in each watertight compartment below the design waterline;
- .5 failure of compass system;
- .6 low level of a fuel tank contents;
- .7 fuel oil tank overflow;
- .8 extinction of side, masthead or stern navigation lights;
- .9 low level of contents of any fluid reservoir the contents of which are essential for normal craft operation;
- .10 failure of any connected electrical power source;
- .11 failure of any ventilation fan installed for ventilating spaces in which inflammable vapours may accumulate; and
- .12 diesel engine fuel line failure as required by 9.4.2.

11.4.1.3 All warnings required by 11.4.1.1 and 11.4.1.2 shall be provided at all stations at which control functions may be exercised.

11.4.2 The alarm system shall meet appropriate constructional and operational requirements for required alarms⁶¹.

11.4.3 Equipment monitoring the passenger, cargo and machinery spaces for fire and flooding shall, so far as is practicable, form an integrated sub-centre incorporating monitoring and activation control for all emergency situations. This sub-centre may require feedback instrumentation to indicate that actions initiated have been fully implemented.

⁶¹ Refer to the Code on Alarms and Indicators, 1995, adopted by the Organization by resolution A.830(19).

11.5 Safety system

11.5.1 Where arrangements are fitted for overriding any automatic shutdown system for the main propulsion machinery in accordance with 9.2.2, they shall be such as to preclude inadvertent operation. When a shutdown system is activated, an audible and visual alarm shall be given at the control station and means shall be provided to override the automatic shutdown except in cases where there is a risk of complete breakdown or explosion.

CHAPTER 12

Electrical Installations

PART A - GENERAL

12.1 General

12.1.1 Electrical installations⁶² shall be such that:

- .1 all electrical auxiliary services necessary for maintaining the craft in normal operation and habitable conditions will be ensured without recourse to the emergency source of electrical power;
- .2 electrical services essential for safety will be ensured under various emergency conditions; and
- .3 the safety of passengers, crew and craft from electrical hazards will be ensured.

The FMEA shall include the electrical system, taking into account the effects of electrical failure on the systems being supplied. In cases where faults can occur without being detected during routine checks on the installations, the analysis shall take into account the possibility of faults occurring simultaneously or consecutively.

12.1.2 The electrical system shall be designed and installed so that the probability of the craft being at risk of failure of a service is extremely remote.

12.1.3 Where loss of particular essential service would cause serious risk to the craft, the service shall be fed by at least two independent circuits fed in such a way that no single failure in the electrical supply or distribution systems would affect both supplies.

12.1.4 The securing arrangements for heavy items, i.e. accumulator batteries, shall, as far as practicable, prevent excessive movement during the accelerations due to grounding or collision.

⁶² Refer to the recommendations published by the International Electrotechnical Commission and, in particular, Publication 60092 - Electrical Installations in Ships.

12.1.5 Precautions shall be taken to minimise risk of supplies to essential and emergency services being interrupted by the inadvertent or accidental opening of switches or circuit-breakers.

12.2 Main source of electrical power

12.2.1 A main source of electrical power of sufficient capacity to supply all those services mentioned in 12.1.1 shall be provided. The main source of electrical power shall consist of at least two generating sets.

12.2.2 The capacity of these generating sets shall be such that, in the event of any one generating set being stopped or failing, it will still be possible to supply those services necessary to provide the normal operational conditions of propulsion and safety. Minimum comfortable conditions of habitability shall also be ensured which include at least adequate services for cooking, heating, domestic refrigeration, mechanical ventilation, and sanitary and fresh water.

12.2.3 The arrangements of the craft's main source of electrical power shall be such that the services referred to in 12.1.1.1 can be maintained regardless of the speed and direction of the propulsion machinery or shafting.

12.2.4 In addition, the generating sets shall be such as to ensure that, with any one generator or its primary source of power out of operation, the remaining generating set shall be capable of providing the electrical services necessary to start the main propulsion plant from dead craft condition. The emergency source of electrical power may be used for the purpose of starting from a dead craft condition if its capability either alone or combined with that of any other source of electrical power is sufficient to provide at the same time those services required to be provided by 12.7.3.1 to 12.7.3.3 or 12.7.4.1 to 12.7.4.4 or 12.8.2.1 to 12.8.2.4.1, as appropriate.

12.2.5 Where transformers constitute an essential part of the electrical supply system required by this section, the system shall be so arranged as to ensure the same continuity of supply as is stated in 12.2.

12.2.6 A main electric lighting system which shall provide illumination throughout those parts of the craft normally accessible to and used by passengers and crew shall be supplied from the main source of electrical power.

12.2.7 The arrangement of the main electric lighting system shall be such that a fire or other casualty in spaces containing the emergency source of electrical power, associated transforming equipment, if any, the emergency switchboard and the emergency lighting switchboard will not render inoperative the main electric lighting systems required by 12.2.6.

12.2.8 The main switchboard shall be so placed relative to one main generating station that, as far as practicable, the integrity of the normal electrical supply may be affected only by a fire or other casualty in one space. An environmental enclosure for the main switchboard, such as may be provided by the machinery control room situated within the main boundaries of the space, shall not be considered as separating the switchboards from the generators.

12.2.9 The main busbars shall be subdivided into at least two parts which shall be connected by a circuit-breaker or other approved means. So far as is practicable, the connection of generating sets and any other duplicated equipment shall be equally divided between the parts. For category B craft, each part of the main busbars with its associated generators shall be arranged in separate compartments.

12.3 Emergency source of electrical power

12.3.1 A self-contained emergency source of electrical power shall be provided.

12.3.2 The emergency source of electrical power, associated transforming equipment, if any, transitional source of emergency electrical power, emergency switchboard and emergency lighting switchboard shall be located above the waterline in the final condition of damage as referred to in chapter 2, operable in that condition and readily accessible.

12.3.3 The location of the emergency source of electrical power and associated transforming equipment, if any, the transitional source of emergency power, the emergency switchboard and the emergency electrical lighting switchboards in relation to the main source of electrical power, associated transforming equipment, if any, and the main switchboard shall be such as to ensure that a fire or other casualty in spaces containing the main source of electrical power, associated transforming equipment, if any, and the main switchboard or in any machinery space will not interfere with the supply, control, and distribution of emergency electrical power. As far as practicable, the space containing the emergency source of electrical power, associated transforming equipment, if any, the transitional source of emergency electrical power and the emergency switchboard shall not be contiguous to the boundaries of the main machinery spaces or those spaces containing the main source of electrical power, associated transforming equipment, if any, or the main switchboard.

12.3.4 Provided that suitable measures are taken for safeguarding independent emergency operation under all circumstances, the emergency generator, if provided, may be used exceptionally, and for short periods, to supply non-emergency circuits.

12.3.5 Distribution systems shall be so arranged that the feeders from the main and emergency sources are separated both vertically and horizontally as widely as practicable.

12.3.6 The emergency source of electrical power may be either a generator or an accumulator battery, which shall comply with the following:

.1 Where the emergency source of electrical power is a generator, it shall be:

.1.1 driven by a suitable prime mover with an independent supply of fuel having a flashpoint which meets the requirements of 7.1.2.2;

.1.2 started automatically upon failure of the electrical supply from the main source of electrical power and shall be automatically connected to the emergency switchboard. Those services referred to in 12.7.5 or 12.8.3 shall then be transferred to the emergency generating set. The automatic starting system and the characteristic of the prime mover shall be such as to permit the emergency generator to carry its full rated load as quickly as is safe and practicable, subject to a maximum of 45 seconds; and

.1.3 provided with a transitional source of emergency electrical power according to 12.7.5 or 12.8.3.

.2 Where the emergency source of electrical power is an accumulator battery, it shall be capable of:

.2.1 carrying the emergency electrical load without recharging while maintaining the voltage of the battery throughout the discharge period within 12% above or below its nominal voltage;

.2.2 automatically connecting to the emergency switchboard in the event of failure of the main source of electrical power; and

.2.3 immediately supplying at least those services specified in 12.7.5 or 12.8.3.

12.3.7 The emergency switchboard shall be installed as near as is practicable to the emergency source of electrical power.

12.3.8 Where the emergency source of electrical power is a generator, the emergency switchboard shall be located in the same space unless the operation of the emergency switchboard would thereby be impaired.

12.3.9 No accumulator battery fitted in accordance with this section shall be installed in the same space as the emergency switchboard. An indicator shall be mounted in a suitable space at the craft's operating compartment to indicate when the batteries constituting either the emergency source of electrical power or the transitional source of emergency electrical power referred to in 12.3.6.1.3 are being discharged.

12.3.10 The emergency switchboard shall be supplied during normal operation from the main switchboard by an interconnector feeder which shall be adequately protected at the main switchboard against overload and short circuit and which shall be disconnected automatically at the emergency switchboard upon failure of the main source of electrical power. Where the system is arranged for feedback operation, the interconnector feeder shall also be protected at the emergency switchboard at least against short circuit. Failure of the emergency switchboard, when being used in other than an emergency, shall not put at risk the operation of the craft.

12.3.11 In order to ensure ready availability of the emergency source of electrical power, arrangements shall be made, where necessary, to disconnect automatically non-emergency circuits from the emergency switchboard to ensure that power shall be available to the emergency circuits.

12.3.12 The emergency generator and its prime mover and any emergency accumulator battery shall be so designed and arranged as to ensure that they will function at full rated power when the craft is upright and when the craft has a list or trimming accordance with 9.1.12 including any damage cases considered in chapter 2, or is in any combination of angles within those limits.

12.3.13 Where accumulator batteries are installed to supply emergency services, provisions shall be made to charge them *in situ* from a reliable on-board supply. Charging facilities shall be so designed to permit the supply of services, regardless of whether battery is on charge or not. Means shall be provided to minimise the risk of overcharging or overheating the batteries. Means for efficient air ventilation shall be provided.

12.4 Starting arrangements for emergency generating sets

12.4.1 Emergency generating sets shall be capable of being readily started in their cold condition at a temperature of 0°C. If this is impracticable, or if lower temperatures are likely to be encountered, provisions shall be made for heating arrangements to ensure ready starting of the generating sets.

12.4.2 Each emergency generating set shall be equipped with starting devices with a stored energy capability of at least three consecutive starts. The source of stored energy shall be protected to preclude critical depletion

by the automatic starting system, unless a second independent means of starting is provided. A second source of energy shall be provided for an additional three starts within 30 min, unless manual starting can be demonstrated to be effective.

12.4.3 The stored energy shall be maintained at all times, as follows:

- .1 electrical and hydraulic starting systems shall be maintained from the emergency switchboard;
- .2 compressed air starting systems may be maintained by the main or auxiliary compressed air receivers through a suitable nonreturn valve or by an emergency air compressor which, if electrically driven, is supplied from the emergency switchboard;
- .3 all of these starting, charging and energy-storing devices shall be located in the emergency generator space. These devices shall not be used for any purpose other than the operation of the emergency generating set. This does not preclude the supply to the air receiver of the emergency generating set from the main or auxiliary compressed air system through the non return valve fitted in the emergency generator space.

12.5 Steering and stabilization

12.5.1 Where steering and/or stabilization of a craft is essentially dependent on one device as with a single rudder or pylon, which is itself dependent on the continuous availability of electric power, it shall be served by at least two independent circuits, one of which shall be fed either from the emergency source of electric power or from an independent power source located in such a position as to be unaffected by fire or flooding affecting the main source of power. Failure of either supply shall not cause any risk to the craft or passengers during switching to the alternative supply and such switching arrangements shall meet the requirements in 5.2.5. These circuits shall be provided with short-circuit protection and an overload alarm.

12.5.2 Protection against excess current may be provided, in which case it shall be for not less than twice the full load current of the motor or circuit so protected and shall be arranged to accept the appropriate starting current with a reasonable margin. Where three-phase supply is used an alarm shall be provided in a readily observed position in the craft's operating compartment that will indicate failure of any one of the phases.

12.5.3 Where such systems are not essentially dependent on the continuous availability of electric power but at least one alternative system, not dependent on the electric supply, is installed, then the electrically powered or controlled system may be fed by a single circuit protected in accordance with 12.5.2.

12.5.4 The requirements of chapters 5 and 16 for power supply of the directional control system and stabilising system of the craft shall be met.

12.6 Precautions against shock, fire and other hazards of electrical origin

12.6.1.1 Exposed metal parts of electrical machines or equipment which are not intended to be live but which are liable under fault conditions to become live shall be earthed unless the machines or equipment are:

- .1 supplied at a voltage not exceeding 50V direct current or 50V, root-mean-square between conductors; auto-transformers shall not be used for the purpose of achieving this voltage; or
- .2 supplied at a voltage not exceeding 250V by safety isolating transformers supplying only one consuming device; or
- .3 constructed in accordance with the principle of double insulation.

12.6.1.2 The Administration may require additional precautions for portable electrical equipment for use in confined or exceptionally damp spaces where particular risks due to conductivity may exist.

12.6.1.3 All electrical apparatus shall be constructed and so installed as not to cause injury when handled or touched in the normal manner.

12.6.2 Main and emergency switchboards shall be so arranged as to give easy access, as may be needed, to apparatus and equipment, without danger to personnel. The sides and the rear and, where necessary, the front of switchboards shall be suitably guarded. Exposed live parts having voltages to earth exceeding a voltage to be specified by the Administration shall not be installed on the front of such switchboards. Where necessary, nonconducting mats or gratings shall be provided at the front and rear of the switchboard.

12.6.3 When a distribution system, whether primary or secondary, for power, heating or lighting, with no connection to earth is used, a device capable of continuously monitoring the insulation level to earth and of giving an audible or visual indication of abnormally low insulation values shall be provided. For limited secondary distribution systems the Administration may accept a device for manual checking of the insulation level.

12.6.4 Cables and wiring

12.6.4.1 Except as permitted by the Administration in exceptional circumstances, all metal sheaths and armour of cables shall be electrically continuous and shall be earthed.

12.6.4.2 All electric cables and wiring external to equipment shall be at least of a flame-retardant type and shall be so installed as not to impair their original flame-retarding properties. Where necessary for particular applications, the Administration may permit the use of special types of cables such as radio-frequency cables, which do not comply with the foregoing.

12.6.4.3 Cables and wiring serving essential or emergency power, lighting, internal communications or signals shall, as far as practicable, be routed clear of machinery spaces and their casings and other areas of high fire risk. Where practicable, all such cables shall be run in such a manner as to preclude their being rendered unserviceable by heating of the bulkheads that may be caused by a fire in an adjacent space.

12.6.4.4 Where cables which are installed in hazardous areas introduce the risk of fire or explosion in the event of an electrical fault in such areas, special precautions against such risks shall be taken to the satisfaction of the Administration.

12.6.4.5 Cables and wiring shall be installed and supported in such manner as to avoid chafing or other damage.

12.6.4.6 Terminations and joints in all conductors shall be so made as to retain the original electrical, mechanical, flame-retarding and, where necessary, fire-resisting properties of the cable.

12.6.5.1 Each separate circuit shall be protected against short circuit and against overload, except as permitted in 12.5 or where the Administration may exceptionally otherwise permit.

12.6.5.2 The rating or appropriate setting of the overload protective device for each circuit shall be permanently indicated at the location of the protective device.

12.6.6 Lighting fittings shall be so arranged as to prevent temperature rises which could damage the cables and wiring, and to prevent surrounding material from becoming excessively hot.

12.6.7 All lighting and power circuits terminating in a bunker or cargo space shall be provided with a multiple-pole switch outside the space for disconnecting such circuits.

12.6.8.1 Accumulator batteries shall be suitably housed, and compartments used primarily for their accommodation shall be properly constructed and efficiently ventilated.

12.6.8.2 Electrical or other equipment which may constitute a source of ignition of flammable vapours shall not be permitted in these compartments except as permitted in 12.6.9.

12.6.8.3 Accumulator batteries shall not be located in crew accommodation.

12.6.9 No electrical equipment shall be installed in any space where flammable mixtures are liable to collect, including those in compartments assigned principally to accumulator batteries, in paint lockers, acetylene stores or similar spaces, unless the Administration is satisfied that such equipment is:

- .1 essential for operational purposes;
- .2 of a type which will not ignite the mixture concerned;
- .3 appropriate to the space concerned; and
- .4 appropriately certified for safe usage in the dusts, vapours or gases likely to be encountered.

12.6.10 The following additional requirements from .1 to .7 shall be met, and requirements from .8 to .13 shall be met also for non-metallic craft:

- .1 The electrical distribution voltages throughout the craft may be either direct current or alternating current and shall not exceed:
 - .1.1 500 V for cooking, heating and other permanently connected equipment; and
 - .1.2 250 V for lighting, internal communications and receptacle outlets.

The Administration may accept higher voltages for propulsion purposes.

- .2 For electrical power distribution, two-wire or three-wire systems shall be used. Four-wire systems with neutral solidly earthed but without hull return may also be used. Where applicable, the requirements for 7.5.6.4 or 7.5.6.5 shall also be met.
- .3 Effective means shall be provided so that voltage may be cut off from each and every circuit and sub-circuit and from all apparatus as may be necessary to prevent danger.

- .4 Electrical equipment shall be so designed that the possibility of accidentally touching live parts, rotating or moving parts as well as heated surfaces which might cause burns or initiate fire is minimized.
- .5 Electrical equipment shall be adequately secured. The probability of fire or dangerous consequences arising from damage to electrical equipment shall be reduced to an acceptable minimum.
- .6 The rating or appropriate setting of the overload protective device for each circuit shall be permanently indicated at the location of the protection device.
- .7 Where it is impracticable to provide electrical protective devices for certain cables supplied from batteries, e.g., within battery compartments and in engine starting circuits, unprotected cable runs shall be kept as short as possible and special precautions shall be taken to minimize risk of faults, e.g., use of single-core cables with additional sleeve over the insulation of each core, with shrouded terminals.
- .8 In order to minimize the risk of fire, structural damage, electrical shock and radio interference due to lightning strike or electrostatic discharge, all metal parts of the craft shall be bonded together, in so far as possible in consideration of galvanic corrosion between dissimilar metals, to form a continuous electrical system, suitable for the earth return of electrical equipment and to connect the craft to the water when water-borne. The bonding of isolated components inside the structure is not generally necessary, except in fuel tanks.
- .9 Each pressure refuelling point shall be provided with a means of bonding the fuelling equipment to the craft.
- .10 Metallic pipes capable of generating electrostatic discharges, due to the flow of liquids and gases, shall be bonded so as to be electrically continuous throughout their length and shall be adequately earthed.
- .11 Primary conductors provided for lightning discharge currents shall have a minimum cross-section of 70 mm² in copper or equivalent surge-carrying capacity in aluminium.
- .12 Secondary conductors provided for the equalisation of static discharges, bonding of equipment, etc., but not for carrying lightning discharges shall have a minimum cross section of 5 mm² copper or equivalent surge current carrying capacity in aluminium.

- .13 The electrical resistance between bonded objects and the basic structure shall not exceed 0.02 Ohm except where it can be demonstrated that a higher resistance will not cause a hazard. The bonding path shall have sufficient cross-sectional area to carry the maximum current likely to be imposed on it without excessive voltage drop.

PART B - REQUIREMENTS FOR PASSENGER CRAFT

12.7 General

12.7.1 Separation and duplication of electrical supply shall be provided for duplicated consumers of essential services. During normal operation the systems may be connected to the same power-bus, but facilities for easy separation shall be provided. Each system shall be able to supply all equipment necessary to maintain the control of propulsion, steering, stabilization, navigation, lighting and ventilation, and allow starting of the largest essential electric motor at any load. Automatic load-dependent disconnection of non-essential consumers may be allowed.

12.7.2 Emergency source of electrical power

Where the main source of electrical power is located in two or more compartments which are not contiguous, each of which has its own self-contained systems, including power distribution and control systems, completely independent of each other and such that a fire or other casualty in any one of the spaces will not affect the power distribution from the others, or to the services required by 12.7.3 or 12.7.4, the requirement of 12.3.1, 12.3.2 and 12.3.4 may be considered satisfied without an additional emergency source of electrical power, provided that:

- .1 there is at least one generating set, meeting the requirements of 12.3.12 and of sufficient capacity to meet the requirements of 12.7.3 or 12.7.4 in each of at least two non-contiguous spaces;
- .2 the arrangements required by .1 in each such space are equivalent to those required by 12.3.6.1, 12.3.7 to 12.3.11 and 12.4 so that a source of electrical power is available at all times to the services required by 12.7.3 or 12.7.4; and
- .3 the generator sets referred to in .1 and their self-contained systems are installed such that one of them remains operable after damage or flooding in any one compartment.

12.7.3 For category A craft, the emergency source of power shall be capable of supplying simultaneously the following services:

- .1 for a period of 5 h emergency lighting:
 - .1.1 at the stowage, preparation, launching and deployed positions of survival craft and equipment for embarkation into those craft;
 - .1.2 at all escape routes, such as alleyways, stairways, exits from accommodation and service spaces, embarkation points, etc;
 - .1.3 in the public spaces;
 - .1.4 in the machinery spaces and main emergency generator spaces, including their control positions;
 - .1.5 in control stations;
 - .1.6 at the stowage positions for firemen's outfits; and
 - .1.7 at the steering gear;
- .2 for a period of 5 h;
 - .2.1 main navigation lights, except for "not under command" lights;
 - .2.2 electrical internal communication equipment for announcements for passengers and crew required during evacuation;
 - .2.3 fire-detection and general alarm system and manual fire alarms; and
 - .2.4 remote control devices of fire-extinguishing systems, if electrical;
- .3 for a period of 4 h of intermittent operation:
 - .3.1 the daylight signalling lamps, if they have no independent supply from their own accumulator battery; and
 - .3.2 the craft's whistle, if electrically driven;
- .4 for a period of 5 h;
 - .4.1 craft radio facilities and other loads as set out in 14.13.2; and
 - .4.2 essential electrically powered instruments and controls for propulsion machinery, if alternate sources of power are not available for such devices;
- .5 for a period of 12 h, the "not under command" lights; and

- .6 for a period of 10 min:
 - .6.1 power drives for directional control devices, including those required to direct thrust forward and astern, unless there is a manual alternative acceptable to the Administration as complying with 5.2.3.

12.7.4 For category B craft, the electrical power available shall be sufficient to supply all those services that are essential for safety in an emergency, due regard being paid to such services as may have to be operated simultaneously. The emergency source of electrical power shall be capable, having regard to starting currents and the transitory nature of certain loads, of supplying simultaneously at least the following services for the periods specified hereinafter, if they depend upon an electrical source for their operation.

- .1 for a period of 12 h, emergency lighting:
 - .1.1 at the stowage, preparation, launching and deployed positions of survival craft and equipment for embarkation into those craft;
 - .1.2 at all escape routes, such as alleyways, stairways, exits from accommodation and service spaces, embarkation points, etc;
 - .1.3 in the passenger compartments;
 - .1.4 in the machinery spaces and main emergency generating spaces including their control positions;
 - .1.5 in control stations;
 - .1.6 at the stowage positions for firemen's outfits; and
 - .1.7 at the steering gear;
- .2 for a period of 12 h;
 - .2.1 the navigation lights, and other lights required by International Regulations for Preventing Collisions at Sea in force;
 - .2.2 electrical internal communication equipment for announcements for passengers and crew required during evacuation;
 - .2.3 fire-detection and general alarm system and manual fire alarms; and
 - .2.4 remote control devices of fire-extinguishing systems, if electrical;

- .3 for a period of 4 h on intermittent operation:
 - .3.1 the daylight signalling lamps, if they have no independent supply from their own accumulator battery; and
 - .3.2 the craft's whistle, if electrically driven;
- .4 for a period of 12 h;
 - .4.1 the navigational equipment as required by chapter 13. Where such provision is unreasonable or impracticable, the Administration may waive this requirement for craft of less than 5,000 gross tonnage;
 - .4.2 essential electrically powered instruments and controls for propulsion machinery, if alternate sources of power are not available for such devices;
 - .4.3 one of the fire pumps required by 7.7.5.1;
 - .4.4 the sprinkler pump and drencher pump, if fitted;
 - .4.5 the emergency bilge pump and all the equipment essential for the operation of electrically powered remote controlled bilge valves as required by chapter 10; and
 - .4.6 craft radio facilities and other loads as set out in 14.13.2;
- .5 for a period of 30 min, any watertight doors, required by chapter 2 to be power-operated, together with their indicators and warning signals;
- .6 for a period of 10 min, power drives for directional control devices including those required to direct thrust forward and astern, unless there is a manual alternative acceptable to the Administration as complying with 5.2.3.

12.7.5 Transitional source of emergency electrical power

The transitional source of emergency electrical power required by paragraph 12.3.6.1.3 may consist of an accumulator battery suitably located for use in an emergency which shall operate without recharging while maintaining the voltage of the battery throughout the discharge period within 12% above or below its nominal voltage and be of sufficient capacity and so arranged as to supply automatically in the event of failure of either the main or emergency source of electrical power at least the following services, if they depend upon an electrical source for their operation:

- .1 for a period of 30 min, the load specified in 12.7.3.1, .2 and .3, or in 12.7.4.1, .2 and .3; and
- .2 with respect to the watertight doors:
 - .2.1 power to operate the watertight doors, but not necessarily simultaneously, unless an independent temporary source of stored energy is provided. The power source shall have

sufficient capacity to operate each door at least three times, i.e. closed-open-closed, against an adverse list of 15°; and

- .2.2 power to the control, indication and alarm circuits for the watertight doors for half an hour.

12.7.6 The requirements of 12.7.5 may be considered satisfied without the installation of a transitional source of emergency electrical power if each of the services required by that paragraph have independent supplies, for the period specified, from accumulator batteries suitably located for use in an emergency. The supply of emergency power to the instruments and controls of the propulsion and direction systems shall be uninterrupted.

12.7.7 In category A craft having limited public spaces, emergency lighting fittings of the type described in 12.7.9.1 as meeting the requirements of 12.7.3.1 and 12.7.5.1 may be accepted, provided that an adequate standard of safety is attained.

12.7.8 Provisions shall be made for the periodic testing of the complete emergency system, including the emergency consumers required by 12.7.3 or 12.7.4 and 12.7.5, and shall include the testing of automatic starting arrangements.

12.7.9 In addition to the emergency lighting required by paragraph 12.7.3.1, 12.7.4.1 and 12.7.5.1 on every craft with ro-ro spaces:

- .1 all passenger public spaces and alleyways shall be provided with supplementary electric lighting that can operate for at least three h when all other sources of electric power have failed and under any condition of heel. The illumination provided shall be such that the approach to the means of escape can be readily seen. The source of power for the supplementary lighting shall consist of accumulator batteries located within the lighting units that are continuously charged, where practicable, from the emergency switchboard. Alternatively, any other means of lighting, which is at least as effective, may be accepted by the Administration.

The supplementary lighting shall be such that any failure of the lamp will be immediately apparent. Any accumulator battery provided shall be replaced at intervals having regard to the specified service life in the ambient condition that it is subject to in service; and

- .2 a portable rechargeable battery-operated lamp shall be provided in every crew space alleyway, recreational space and every working space which is normally occupied unless supplementary emergency lighting, as required by .1, is provided.

12.7.10 Distribution systems shall be so arranged that fire in any main vertical zone will not interfere with services essential for safety in any other such zone. This requirement will be met if main and emergency feeders passing through any such zone are separated both vertically and horizontally as widely as is practicable.

PART C - REQUIREMENTS FOR CARGO CRAFT

12.8 General

12.8.1 Separation and duplication of electrical supply shall be provided for duplicated consumers of essential services. During normal operation these consumers may be connected to the same power-bus directly or via distribution boards or group starters, but shall be separated by removable links or other approved means. Each power-bus shall be able to supply all equipment necessary to maintain the control of propulsion, steering, stabilization, navigation, lighting and ventilation, and allow starting of the largest essential electric motor at any load. However, having regard to 12.1.2, partial reduction in the capability from normal operation may be accepted. Non-duplicated consumers of essential services connected to the emergency switchboard directly or via distribution boards may be accepted. Automatic load-dependent disconnection of non-essential consumers may be allowed.

12.8.2 Emergency source of electrical power

12.8.2.1 Where the main source of electrical power is located in two or more compartments which are not contiguous, each of which has its own self-contained systems, including power distribution and control systems, completely independent of each other and such that a fire or other casualty in any one of the spaces will not affect the power distribution from the others, or to the services required by 12.8.2.2, the requirements of 12.3.1, 12.3.2 and 12.3.4 may be considered satisfied without an additional emergency source of electrical power, provided that:

- .1 there is at least one generating set, meeting the requirements of 12.3.12 and each of sufficient capacity to meet the requirements of 12.8.2.2, in each of at least two non-contiguous spaces;
- .2 the arrangements required by .1 in each such space are equivalent to those required by 12.3.6.1, 12.3.7 to 12.3.11 and 12.4 so that a source of electrical power is available at all times to the services required by 12.8.2; and

- .3 the generator sets are referred to in .1 and their self-contained systems are installed in accordance with 12.3.2.

12.8.2.2 The electrical power available shall be sufficient to supply all those services that are essential for safety in an emergency, due regard being paid to such services as may have to be operated simultaneously. The emergency source of electrical power shall be capable, having regard to starting currents and the transitory nature of certain loads, of supplying simultaneously at least the following services for the periods specified hereinafter, if they depend upon an electrical source for their operation:

- .1 for a period of 12 h, emergency lighting;
 - .1.1 at the stowage positions of life-saving appliances;
 - .1.2 at all escape routes, such as alleyways, stairways, exits from accommodation and service spaces, embarkation points, etc.;
 - .1.3 in public spaces, if any;
 - .1.4 in the machinery spaces and main emergency generator spaces including their control positions;
 - .1.5 in control stations;
 - .1.6 at the stowage positions for fire-fighter's outfits; and
 - .1.7 at the steering gear;
- .2 for a period of 12 h;
 - .2.1 the navigation lights, and other lights required by the International Regulations for Preventing Collisions at Sea in force;
 - .2.2 electrical internal communication equipment for announcements during evacuation;
 - .2.3 fire-detection and general alarm system and manual fire alarms; and
 - .2.4 remote control devices of fire-extinguishing systems, if electrical;
- .3 for a period of 4 h of intermittent operation;
 - .3.1 the daylight signalling lamps, if they have no independent supply from their own accumulator battery; and
 - .3.2 the craft's whistle, if electrically driven;

- .4 for a period of 12 h;
 - .4.1 the navigational equipment as required by chapter 13. Where such provision is unreasonable or impracticable, the Administration may waive this requirement for craft of less than 5,000 gross tonnage;
 - .4.2 essential electrically powered instruments and controls for propulsion machinery, if alternate sources of power are not available for such devices;
 - .4.3 one of the fire pumps required by 7.7.5.1;
 - .4.4 the sprinkler pump and drencher pump, if fitted;
 - .4.5 the emergency bilge pump and all the equipment essential for the operation of electrically powered remote controlled bilge valves as required by chapter 10; and
 - .4.6 craft radio facilities and other loads as set out in 14.13.2.
- .5 for a period of 10 min, power drives for directional control devices, including those required to direct thrust forward and astern, unless there is a manual alternative acceptable to the Administration as complying with 5.2.3.

12.8.2.3 Provision shall be made for the periodic testing of the complete emergency system, including the emergency consumers required by 12.8.2.2 and shall include the testing of automatic starting arrangements.

12.8.2.4 Where the emergency source of electrical power is a generator, a transitional source of emergency power shall be provided according to 12.8.3, unless the automatic starting system and the characteristics of the prime mover are such as to permit the emergency generator to carry its full rated load as quickly as is safe and practicable, subject to a maximum of 45 s.

12.8.3 Transitional source of emergency electrical power

The transitional source of emergency electrical power required by 12.8.2.4 may consist of an accumulator battery suitably located for use in an emergency which shall operate without recharging while maintaining the voltage of the battery throughout the discharge period within 12% above or below its nominal voltage and be of sufficient capacity and so arranged as to supply automatically, in the event of failure of either the main or emergency source of electrical power, at least the following services, if they depend upon an electrical source for their operation:

- .1 for a period of 30 min, the load specified in 12.8.2.2.1, .2 and .3; and
- .2 with respect to watertight doors:

- .2.1 power to operate the watertight doors, but not necessarily simultaneously, unless an independent temporary source of stored energy is provided. The power source shall have sufficient capacity to operate each door at least three times, i.e. closed-open-closed, against an adverse list of 15°; and
- .2.2 power to the control, indication and alarm circuits for the watertight doors for half an hour.

CHAPTER 13

Shipborne Navigational Systems and Equipment and Voyage Data Recorders

13.1 General

13.1.1 This chapter covers items of equipment which relate to the navigation of the craft as distinct from the safe functioning of the craft. The following paragraphs set out the minimum requirements.

13.1.2 The equipment and its installation shall be to the satisfaction of the Administration. The Administration shall determine to what extent the provisions of this chapter do not apply to craft below 150 gross tonnage.

13.1.3 The information provided by navigational systems and equipment shall be so displayed that the probability of misreading is reduced to a minimum. Navigational systems and equipment shall be capable of giving readings to an optimum accuracy.

13.2 Compasses

13.2.1 Craft shall be provided with a magnetic compass which is capable of operating without electrical supply, and which may be used for steering purposes. This compass shall be mounted in a suitable binnacle containing the required correcting devices and shall be suitable for the speed and motion characteristics of the craft.

13.2.2 The compass card or repeater shall be capable of being easily read from the position at which the craft is normally controlled.

13.2.3 Each magnetic compass shall be properly adjusted and its table or curve of residual deviations shall be available at all times.

13.2.4 Care shall be taken in siting a magnetic compass or magnetic sensing element so that magnetic interference is eliminated or minimized as far as is practicable.

13.2.5 Passenger craft certified to carry 100 passengers or less shall, in addition to the compass required by 13.2.1, be provided with a properly adjusted transmitting heading device, suitable for the speed and motion characteristics and area of operation of the craft, capable of transmitting a true heading reference to other equipment.

13.2.6 Passenger craft certified to carry more than 100 passengers and cargo craft shall, in addition to the compass required in 13.2.1, be provided with a gyro-compass which shall be suitable for the speed and motion characteristics and area of operation of the craft.

13.3 Speed and distance measurement

13.3.1 Craft shall be provided with a device capable of indicating speed and distance.

13.3.2 Speed- and distance-measuring devices on craft fitted with an automatic radar plotting aid (ARPA) or automatic tracking aid (ATA) shall be capable of measuring speed and distance through the water.

13.4 Echo-sounding device

13.4.1 Non-amphibious craft shall be provided with an echo-sounding device which will give an indication of depth of water to a sufficient degree of accuracy for use when the craft is in the displacement mode.

13.5 Radar installations

13.5.1 Craft shall be provided with at least one azimuth-stabilized radar operating on 9 GHz.

13.5.2 Craft of 500 gross tonnage and upwards or craft certified to carry more than 450 passengers shall also be provided with a 3 GHz radar or where considered appropriate by the Administration, a second 9 GHz radar or other means to determine and display the range and bearing of other surface craft, obstructions, buoys, shorelines and navigational marks to assist in navigation and in collision avoidance, which are functionally independent of those referred to in 13.5.1.

13.5.3 At least one radar shall be provided with facilities for an ARPA or ATA suitable for the motion and speed of the craft.

13.5.4 Adequate communication facilities shall be provided between the radar observer and the person in immediate charge of the craft.

13.5.5 Each radar installation provided shall be suitable for the intended craft speed, motion characteristics and commonly encountered environmental conditions.

13.5.6 Each radar installation shall be mounted so as to be as free as practicable from vibration.

13.6 Electronic positioning systems

Craft shall be provided with a receiver for a global navigation satellite system or a terrestrial radio navigation system, or other means, suitable for use at all times throughout the intended voyage to establish and update the craft's position by automatic means.

13.7 Rate-of-turn indicator and rudder angle indicator

13.7.1 Craft of 500 gross tonnage or upwards shall be provided with a rate-of-turn indicator. A rate-of-turn indicator shall be provided in craft of less than 500 gross tonnage if the test according to annex 9 shows that the turn rate can exceed safety level 1.

13.7.2 Craft shall be provided with an indicator showing the rudder angle. In craft without a rudder, the indicator shall show the direction of steering thrust.

13.8 Nautical charts and nautical publications

13.8.1 Craft shall be provided with nautical charts and nautical publications to plan and display the ship's route for the intended voyage and to plot and monitor positions throughout the voyage; an electronic chart display and information system (ECDIS) may be accepted as meeting the chart carriage requirements of this paragraph.

13.8.2 High-speed craft shall be fitted with an ECDIS as follows:

- .1 craft constructed on or after 1 July 2008;
- .2 craft constructed before 1 July 2008, not later than 1 July 2010.

13.8.3 Back-up arrangements shall be provided to meet the functional requirements of 13.8.1, if this function is partly or fully fulfilled by electronic means.

13.9 Searchlight and daylight signalling lamp

13.9.1 Craft shall be provided with at least one adequate searchlight, which shall be controllable from the operating station.

13.9.2 One portable daylight signalling lamp shall be provided and maintained ready for use in the operating compartment at all times.

13.10 Night vision equipment

13.10.1 When operational conditions justify the provision of night vision equipment, such equipment shall be provided.

13.11 Steering arrangement and propulsion indicator(s)

13.11.1 The steering arrangement shall be so designed that the craft turns in the same direction as that of the wheel, tiller, joystick or control lever.

13.11.2 Craft shall be provided with means to show the mode of the propulsion system(s).

13.11.3 Craft with emergency steering positions shall be provided with arrangements for supplying visual compass readings to the emergency steering position.

13.12 Automatic steering aid (automatic pilot)

13.12.1 Craft shall be provided with an automatic steering aid (automatic pilot).

13.12.2 Provision shall be made to change from the automatic to manual mode by a manual override.

13.13 Radar reflector

If practicable, craft of 150 gross tonnage or below shall be provided with a radar reflector, or other means, to assist detection by ships navigating by radar at both 9 and 3 GHz.

13.14 Sound reception system

When the craft's bridge is totally enclosed and unless the Administration determines otherwise, craft shall be provided with a sound reception system, or other means, to enable the officer in charge of the navigational watch to hear sound signals and determine their direction.

13.15 Automatic identification system

13.15.1 Craft shall be provided with an automatic identification system (AIS).

13.15.2 AIS shall:

- .1 provide automatically to appropriately equipped shore stations, other vessels and aircraft information, including the craft's identity, type, position, course, speed, navigational status and other safety-related information;
- .2 receive automatically such information from similarly fitted vessels;

- .3 monitor and track vessels; and
- .4 exchange data with shore based facilities.

13.15.3 The requirements of 13.15.2 shall not apply where international agreements, rules or standards provide for the protection of navigational information.

13.15.4 AIS shall be operated taking into account the guidelines adopted by the Organization⁶³.

13.16 Voyage data recorder

13.16.1 To assist in casualty investigations, passenger craft irrespective of size and cargo craft of 3,000 gross tonnage and upwards shall be provided with a voyage data recorder (VDR).

13.16.2 The voyage data recorder system, including all sensors, shall be subjected to an annual performance test. The test shall be conducted by an approved testing or servicing facility to verify the accuracy, duration and recoverability of the recorded data. In addition, tests and inspections shall be conducted to determine the serviceability of all protective enclosures and devices fitted to aid location. A copy of the certificate of compliance issued by the testing facility, stating the date of compliance and the applicable performance standards, shall be retained on board the craft.

13.17 Approval of systems and equipment, and performance standards

13.17.1 All equipment to which this chapter applies shall be of a type approved by the Administration. Such equipment shall conform to performance standards not inferior to those adopted by the Organization.

13.17.2 The Administration shall require that manufacturers have a quality control system audited by a competent authority to ensure continuous compliance with the type approval conditions. Alternatively, the Administration may use final product verification procedures where compliance with the type approval certificate is verified by a competent authority before the product is installed on board craft.

13.17.3 Before giving approval to navigational systems or equipment embodying new features not covered by this chapter, the Administration shall ensure that such features support functions at least as effective as those required by this chapter.

⁶³ Refer to resolution A.917(22), Guidelines for the Onboard Operational Use of Shipborne Automatic Identification Systems (AIS).

13.17.4 When equipment, for which performance standards have been developed by the Organization, is carried on craft in addition to those items of equipment required by this chapter, such additional equipment shall be subject to approval and shall, as far as practicable, comply with performance standards not inferior to those adopted by the Organization⁶⁴.

64 Recommendation on performance standards for magnetic compasses (resolution A.382(X));
Recommendation on performance standards for marine transmitting magnetic heading devices (TMHDs) (resolution MSC.86(70), annex 2);
Recommendation on performance standards for Gyro-compasses for high-speed craft (resolution A.821(19));
Recommendation on performance standards for devices to indicate speed and distance (resolution A.824(19), as amended by resolution MSC.96(72));
Recommendation on performance standards for echo-sounding equipment (resolution A.224(VII) as amended by MSC.74(69), annex 2);
Recommendation on performance standards for navigational radar equipment for high-speed craft (resolution A.820(19));
Recommendation on performance standards for "Auto Tracking" (resolution MSC.64(67), annex 4, appendix 1);
Recommendation on performance standards for shipborne Decca navigator receivers (resolution A.816(19));
Recommendation on performance standards for shipborne Loran-C and Chayka receivers (resolution A.818(19));
Recommendation on performance standards for shipborne global positioning system receiver equipment (resolution A.819(19));
Recommendation on performance standards for shipborne GLONASS receiver equipment (resolution MSC.53(66));
Recommendation on performance standards for shipborne DGPS and DGLONASS maritime radio beacon receiver equipment (resolution MSC.64(67), annex 2);
Recommendation on performance standards for combined GPS/GLONASS receiver equipment (resolution MSC.74(69), annex 1);
Performance standards for rate-of-turn indicators (resolution A.526(13));
Recommendation on performance standards for night vision equipment for high-speed craft (resolution MSC.94(72));
Recommendation on performance standards for daylight signalling lamps (resolution MSC.95(72)); and
Recommendation on performance standards for automatic steering aids (automatic pilots) for high-speed craft (resolution A.822(19)).

CHAPTER 14

Radiocommunications

14.1 Application

14.1.1 Unless expressly provided otherwise, this chapter applies to all craft specified in 1.3.1 and 1.3.2.

14.1.2 This chapter does not apply to craft to which this Code would otherwise apply while such craft are being navigated within the Great Lakes of North America and their connecting and tributary waters as far east as the lower exit of the St. Lambert Lock at Montreal in the Province of Quebec, Canada⁶⁵.

14.1.3 No provision in this chapter shall prevent the use by any craft, survival craft or person in distress of any means at their disposal to attract attention, make known their position and obtain help.

14.2 Terms and definitions

14.2.1 For the purpose of this chapter, the following terms shall have the meanings defined below:

- .1 "Bridge-to-bridge communications" means safety communications between craft and ships from the position from which the craft is normally navigated.
- .2 "Continuous watch" means that the radio watch concerned shall not be interrupted other than for brief intervals when the craft's receiving capability is impaired or blocked by its own communications or when the facilities are under periodical maintenance or checks.
- .3 "Digital selective calling (DSC)" means a technique using digital codes which enables a radio station to establish contact with, and transfer information to, another station or group of stations, and complying with the relevant recommendations of the International Telecommunication Union Radiocommunication Sector (ITU-R).

⁶⁵ Such craft are subject to special requirements relative to radio for safety purposes, as contained in the relevant agreement between Canada and the United States.

- .4 "Direct-printing" telegraphy means automated telegraphy techniques which comply with the relevant recommendations of the International Telecommunication Union Radiocommunication Sector (ITU-R).
- .5 "General radiocommunications" means operational and public correspondence traffic other than distress, urgency and safety messages, conducted by radio.
- .6 "Global maritime distress and safety system (GMDSS) identities" means maritime mobile services identity, the craft's call sign, recognized mobile satellite service identities and serial number identity which may be transmitted by the craft's equipment and used to identify the craft. (TSFS 2023:58)
- .7 "Inmarsat" means the Organization established by the Convention on the International Maritime Satellite Organization (Inmarsat) adopted on 3 September 1976.
- .8 "International NAVTEX" service means the coordinated broadcast and automatic reception on 518 kHz of maritime safety information by means of narrow-band direct-printing telegraphy using the English language⁶⁶.
- .9 "Locating" means the finding of the ships, craft, aircraft, units or persons in distress.
- .10 "Maritime safety information" means navigational and meteorological warnings, meteorological forecasts and other urgent safety-related messages broadcast to ships and craft.
- .11 "Polar orbiting satellite service" means a service which is based on polar orbiting satellites which receive and relay distress alerts from satellite EPIRBs and which provides their position.
- .12 "Radio Regulations" mean the Radio Regulations annexed to, or regarded as being annexed to, the most recent International Telecommunication Convention which is in force at any time.
- .13 "Sea area A1" means an area within the radiotelephone coverage of at least one VHF coast station in which continuous DSC alerting is available, as may be defined by a Contracting Government to the Convention.**

⁶⁶ Refer to the NAVTEX Manual approved by the Organization.

- .14 "Sea area A2" means an area, excluding sea area A1, within the radiotelephone coverage of at least one MF coast station in which continuous DSC alerting is available, as may be defined by a Contracting Government to the Convention⁶⁷.
- .15 "Sea area A3" means an area, excluding sea areas A1 and A2, within the coverage of an Inmarsat geostationary satellite in which continuous alerting is available.
- .16 "Sea area A4" means an area outside sea areas A1, A2 and A3.
- .17 "Recognized mobile satellite service" means any service which operates through a satellite system and is recognized by the Organization, for use in the global maritime distress and safety system (GMDSS).

(TSFS 2023:58)

14.2.2 All other terms and abbreviations which are used in this chapter and which are defined in the Radio Regulations and in the International Convention on Maritime Search and Rescue (SAR), 1979, as it may be amended, shall have the meanings as defined in those Regulations and the SAR Convention.

14.3 Exemptions

14.3.1 It is considered highly desirable not to deviate from the requirements of this chapter; nevertheless the Administration, in conjunction with the base port State, may grant partial or conditional exemptions to individual craft from the requirements of 14.7 to 14.11 provided:

- .1 such craft comply with the functional requirements of 14.5; and
- .2 the Administration has taken into account the effect such exemptions may have upon the general efficiency of the service for the safety of all ships and craft.

14.3.2 An exemption may be granted under 14.3.1 only:

- .1 if the conditions affecting safety are such as to render the full application of 14.7 to 14.11 unreasonable or unnecessary; or

⁶⁷ Refer to the Provision of radio services for the global maritime distress and safety system (GMDSS), adopted by the Organization by resolution A.801(19).

- .2 in exceptional circumstances, for a single voyage outside the sea area or sea areas for which the craft is equipped.

14.3.3 Each Administration shall submit to the Organization, as soon as possible after the first of January in each year, a report showing all exemptions granted under 14.3.1 and 14.3.2 during the previous calendar year and giving the reasons for granting such exemptions.

14.4 Global Maritime Distress and Safety System Identities

14.4.1 This section applies to all craft on all voyages.

14.4.2 Each Administration undertakes to ensure that suitable arrangements are made for registering Global Maritime Distress and Safety System (GMDSS) Identities and for making information on these identities available to Rescue Co-ordination Centres on a 24-hour basis. Where appropriate, international organizations maintaining a registry of these identities shall be notified by the Administration of these assignments.

14.5 Functional requirements

14.5.1 Every craft, while at sea, shall be capable:

- .1 except as provided in 14.8.1.1 and 14.10.1.4.3, of transmitting ship-to-shore distress alerts by at least two separate and independent means, each using a different radiocommunication service;
- .2 of receiving shore-to-ship distress alerts;
- .3 of transmitting and receiving ship-to-ship distress alerts;
- .4 of transmitting and receiving search and rescue co-ordinating communications;
- .5 of transmitting and receiving on-scene communications;
- .6 of transmitting and, as required by 13.5, receiving signals for locating⁶⁸;
- .7 of transmitting and receiving⁶⁹ maritime safety information;

⁶⁸ Refer to Carriage of radar operating in the frequency band 9,300 - 9,500 MHz, adopted by the Organization by resolution A.614(15).

⁶⁹ It should be noted that craft may have a need for reception of certain maritime safety information while in port.

- .8 of transmitting and receiving general radiocommunications to and from shore-based radio systems or networks subject to 14.15.8; and
- .9 of transmitting and receiving bridge-to-bridge communications.

14.6 Radio installations

14.6.1 Every craft shall be provided with radio installations capable of complying with the functional requirements prescribed by 14.5 throughout its intended voyage and, unless exempted under 14.3, complying with the requirements of 14.7 and, as appropriate for the sea area or areas through which it will pass during its intended voyage, the requirements of either 14.8, 14.9, 14.10 or 14.11.

14.6.2 Every radio installation shall:

- .1 be so located that no harmful interference of mechanical, electrical or other origin affects its proper use, and so as to ensure electromagnetic compatibility and avoidance of harmful interaction with other equipment and systems;
- .2 be so located as to ensure the greatest possible degree of safety and operational availability;
- .3 be protected against harmful effects of water, extremes of temperature and other adverse environmental conditions;
- .4 be provided with reliable, permanently arranged electrical lighting, independent of the main sources of electrical power, for the adequate illumination of the radio controls for operating the radio installation; and
- .5 be clearly marked with the call sign, the ship station identity and other codes as applicable for the use of the radio installation.

14.6.3 Control of the VHF radiotelephone channels, required for navigational safety, shall be immediately available on the navigating bridge convenient to the conning position, and, where necessary, facilities shall be available to permit radiocommunications from the wings of the navigating bridge. Portable VHF equipment may be used to meet the latter provision.

14.6.4 In passenger craft, a distress panel shall be installed at the conning position. This panel shall contain either one single button which, when pressed, initiates a distress alert using all radiocommunication installations required on board for that purpose or one button for each individual installation. The panel shall clearly and visually indicate whenever any button or buttons have been pressed. Means shall be provided

to prevent inadvertent activation of the button or buttons. If the satellite EPIRB is used as the secondary means of distress alerting and is not remotely activated, it shall be acceptable to have an additional EPIRB installed in the wheelhouse near the conning position.

14.6.5 In passenger craft, information on the craft's position shall be continuously and automatically provided to all relevant radiocommunication equipment to be included in the initial distress alert when the button or buttons on the distress panel is pressed.

14.6.6 In passenger craft, a distress alert panel shall be installed at the conning position. The distress alarm panel shall provide visual and aural indication of any distress alert or alerts received on board and shall also indicate through which radiocommunication service the distress alerts have been received.

14.7 Radio equipment: general

14.7.1 Every craft shall be provided with:

- .1** a VHF radio installation capable of transmitting and receiving:
 - .1.1** DSC on the frequency 156.525 MHz (channel 70). It shall be possible to initiate the transmission of distress alerts on channel 70 from the position from which the craft is normally navigated; and
 - .1.2** radiotelephony on the frequencies 156.300 MHz (channel 6), 156.650 MHz (channel 13) and 156.800 MHz (channel 16);
- .2** a radio installation capable of maintaining a continuous DSC watch on VHF channel 70 which may be separate from, or combined with, that required by 14.7.1.1.1;
- .3** a search and rescue locating device which:
 - .3.1** shall be so stowed that it can be easily utilized; and
 - .3.2** may be one of those required by 8.2.1.2 for a survival craft;
- .4** a receiver capable of receiving International NAVTEX service broadcasts if the craft is engaged on voyages in any area in which an International NAVTEX service is provided;
- .5** a radio facility for reception of maritime safety information by a recognized mobile satellite service enhanced group calling system if the craft is engaged in voyages in sea area A1, or A2 or A3 but in which an inter-

national NAVTEX service is not provided. However, craft engaged exclusively in voyages in areas where an HF direct-printing telegraphy maritime safety information service is provided and fitted with equipment capable of receiving such service, may be exempt from this requirement⁷⁰.

- .6 subject to the provisions of 14.8.3, a satellite emergency position indicating radio beacon (satellite EPIRB)⁷¹ which shall be:
 - .6.1 capable of transmitting a distress alert through the polar orbiting satellite service operating in the 406 MHz band;
 - .6.2 installed in an easily accessible position;
 - .6.3 ready to be manually released and capable of being carried by one person into a survival craft;
 - .6.4 capable of floating free if the craft sinks and of being automatically activated when afloat; and
 - .6.5 capable of being activated manually.

(TSFS 2023:58)

14.7.2 Every passenger craft shall be provided with means for two-way on-scene radiocommunications for search and rescue purposes using the aeronautical frequencies 121.5 MHz and 123.1 MHz from the position from which the craft is normally navigated.

14.8 Radio equipment: sea area A1

14.8.1 In addition to meeting the requirements of 14.7, every craft engaged on voyages exclusively in sea area A1 shall be provided with a radio installation capable of initiating the transmission of ship-to-shore distress alerts from the position from which the craft is normally navigated, operating either:

- .1 on VHF using DSC; this requirement may be fulfilled by the EPIRB prescribed by 14.8.3, either by installing the EPIRB close to, or by remote activation from, the position from which the craft is normally navigated; or

⁷⁰ Refer to the Recommendation on promulgation of maritime safety information, adopted by the Organization by resolution A.705(17), as amended.

⁷¹ Refer to Search and rescue homing capability, adopted by the Organization by resolution A.616(15).

- .2 through the polar orbiting satellite service on 406 MHz; this requirement may be fulfilled by the satellite EPIRB, required by 14.7.1.6, either by installing the satellite EPIRB close to, or by remote activation from, the position from which the craft is normally navigated; or
- .3 if the craft is on voyages within coverage of MF coast stations equipped with DSC on MF using DSC; or
- .4 on HF using DSC; or
- .5 through a recognized mobile satellite service; this requirement may be fulfilled by:
 - .5.1 a ship earth station;⁷² or
 - .5.2 the satellite EPIRB, required by 14.7.1.6, either by installing the satellite EPIRB close to, or by remote activation from, the position from which the craft is normally navigated.

(TSFS 2023:58)

14.8.2 The VHF radio installation, required by 14.71.1, shall also be capable of transmitting and receiving general radiocommunications using radiotelephony.

14.8.3 Craft engaged on voyages exclusively in sea area A1 may carry, in lieu of the satellite EPIRB required by 14.7.1.6, an EPIRB which shall be:

- .1 capable of transmitting a distress alert using DSC on VHF channel 70 and providing for locating by means of a radar transponder operating in the 9 GHz band;
- .2 installed in an easily accessible position;
- .3 ready to be manually released and capable of being carried by one person into a survival craft;
- .4 capable of floating free if the craft sinks and of being automatically activated when afloat; and
- .5 capable of being activated manually.

⁷² This requirement can be met by recognized mobile satellite service ship earth stations capable of two-way communications, such as Fleet-77 (resolution A.808(19) and MSC.130(75)) or Inmarsat-C (resolution A.807(19), as amended) ship earth stations. Unless otherwise specified, this footnote applies to all requirements for a recognized mobile satellite service ship earth station prescribed by this chapter.

14.9 Radio equipment: sea areas A1 and A2

14.9.1 In addition to meeting the requirements of 14.7, every craft engaged on voyages beyond sea area A1, but remaining within sea area A2, shall be provided with:

- .1 an MF radio installation capable of transmitting and receiving, for distress and safety purposes, on the frequencies:
 - .1.1 2,187.5 kHz using DSC; and
 - .1.2 2,182 kHz using radiotelephony;
- .2 a radio installation capable of maintaining a continuous DSC watch on the frequency 2,187.5 kHz which may be separate from, or combined with, that required by 14.9.1.1.1; and
- .3 means of initiating the transmission of ship-to-shore distress alerts by a radio service other than MF, operating either:
 - .3.1 through the polar orbiting satellite service on 406 MHz; this requirement may be fulfilled by the satellite EPIRB, required by 14.7.1.6, either by installing the satellite EPIRB close to, or by remote activation from, the position from which the craft is normally navigated; or
 - .3.2 on HF using DSC; or.
 - .3.3 through a recognized mobile satellite service by a ship earth station.

(TSFS 2023:58)

14.9.2 It shall be possible to initiate transmission of distress alerts by the radio installations specified in 14.9.1.1 and 14.9.1.3 from the position from which the craft is normally navigated.

14.9.3 The craft shall, in addition, be capable of transmitting and receiving general radiocommunications using radiotelephony or direct-printing telegraphy by either:

- .1 a radio installation operating on working frequencies in the bands between 1,605 kHz and 4,000 kHz or between 4,000 kHz and 27,500 kHz; this requirement may be fulfilled by the addition of this capability in the equipment required by 14.9.1.1; or
- .2 a recognized mobile satellite service ship earth station.

14.10 Radio equipment: sea areas A1, A2 and A3

14.10.1 In addition to meeting the requirements of 14.7, every craft engaged on voyages beyond sea areas A1 and A2, but remaining within sea area A3, shall, if it does not comply with the requirements of 14.10.2, be provided with:

- .1 a recognized mobile satellite service ship earth station capable of:
 - .1.1 transmitting and receiving distress and safety communications using direct-printing telegraphy;
 - .1.2 initiating and receiving distress priority calls;
 - .1.3 maintaining watch for shore-to-ship distress alerts, including those directed to specifically defined geographical areas; and
 - .1.4 transmitting and receiving general radio-communications, using either radiotelephony or direct-printing telegraphy;
- .2 an MF radio installation capable of transmitting and receiving, for distress and safety purposes, on the frequencies:
 - .2.1 2,187.5 kHz using DSC; and
 - .2.2 2,182 kHz using radiotelephony;
- .3 a radio installation capable of maintaining a continuous DSC watch on the frequency 2,187.5 kHz which may be separate from, or combined with, that required by 14.10.1.2.1; and
- .4 means of initiating the transmission of ship-to-shore distress alerts by a radio service operating either:
 - .4.1 through the polar orbiting service on 406 MHz; this requirement may be fulfilled by the satellite EPIRB, required by 14.7.1.6, either by installing the satellite EPIRB close to, or by remote activation from, the position from which the craft is normally navigated; or
 - .4.2 on HF using DSC; or
 - .4.3 through a recognized mobile satellite service by an additional ship earth station.

(TSFS 2023:58)

14.10.2 In addition to meeting the requirements of 14.7, every craft engaged on voyages beyond sea areas A1 and A2, but remaining within sea area A3, shall, if it does not comply with the requirements of 14.10.1, be provided with:

- .1 an MF/HF radio installation capable of transmitting and receiving, for distress and safety purposes, on all distress and safety frequencies in the bands between 1,605 kHz and 4,000 kHz and between 4,000 kHz and 27,500 kHz:
 - .1.1 using DSC;
 - .1.2 using radiotelephony; and
 - .1.3 using direct-printing telegraphy;
- .2 equipment capable of maintaining a DSC watch on 2,187.5 kHz, 8,414.5 kHz and on at least one of the distress and safety DSC frequencies 4,207.5 kHz, 6,312 kHz, 12,577 kHz or 16,804.5 kHz at any time, it shall be possible to select any of these DSC distress and safety frequencies. This equipment may be separate from, or combined with, the equipment required by 14.10.2.1;
- .3 means of initiating the transmission of ship-to-shore distress alerts by a radiocommunication service other than HF operating either:
 - .3.1 through the polar orbiting satellite service on 406 MHz; this requirement may be fulfilled by the satellite EPIRB required by 14.7.1.6, either by installing the satellite EPIRB close to, or by remote activation from, the position from which the craft is normally navigated; or
 - .3.2 through a recognized mobile satellite service by a ship earth station; and
 - .3.2.1 an Inmarsat ship earth station; or
 - .3.2.2 the satellite EPIRB, required by 14.7.1.6, either by installing the satellite EPIRB close to, or by remote activation from, the position from which the craft is normally navigated; and
- .4 in addition, the craft shall be capable of transmitting and receiving general radiocommunications using radiotelephony or direct-printing telegraphy by an MF/HF radio installation operating on working frequencies in the bands between 1,605 kHz and 4,000 kHz and between 4,000 kHz and 27,500 kHz. This requirement may be fulfilled by the addition of this capability in the equipment required by 14.10.2.1.

(TSFS 2023:58)

14.10.3 It shall be possible to initiate transmission of distress alerts by the radio installations specified in 14.10.1.1, 14.10.1.2, 14.10.1.4, 14.10.2.1 and 14.10.2.3 from the position from which the craft is normally navigated.

14.11 Radio equipment: sea areas A1, A2, A3 and A4

14.11.1 In addition to meeting the requirements of 14.7, craft engaged on voyages in all sea areas shall be provided with the radio installations and equipment required by 14.10.2, except that the equipment required by 14.10.2.3.2 shall not be accepted as an alternative to that required by 14.10.2.3.1, which shall always be provided. In addition, craft engaged on voyages in all sea areas shall comply with the requirements of 14.10.3.

14.12 Watches

14.12.1 Every craft, while at sea, shall maintain a continuous watch:

- .1** on VHF DSC channel 70, if the craft, in accordance with the requirements of 14.7.1.2, is fitted with a VHF radio installation;
- .2** on the distress and safety DSC frequency 2,187.5 kHz, if the craft, in accordance with the requirements of 14.9.1.2 or 14.10.1.3, is fitted with an MF radio installation;
- .3** on the distress and safety DSC frequencies 2,187.5 kHz and 8,414.5 kHz and also on at least one of the distress and safety DSC frequencies 4,207.5 kHz, 6,312 kHz, 12,577 kHz or 16,804.5 kHz, appropriate to the time of day and the geographical position of the craft, if the craft, in accordance with the requirements of 14.10.2.2 or 14.11.1, is fitted with an MF/HF radio installation. This watch may be kept by means of a scanning receiver; and
- .4** for satellite shore-to-ship distress alerts, if the craft, in accordance with the requirements of 14.10.1.1, is fitted with a recognized mobile service ship earth station.

(TSFS 2023:58)

14.12.2 Every craft, while at sea, shall maintain a radio watch for broadcasts of maritime safety information on the appropriate frequency or frequencies on which such information is broadcast for the area in which the craft is navigating.

14.12.3 Until 1 February 2005, every craft, while at sea shall continue to maintain, when practicable, a continuous listening watch on VHF channel 16. This watch shall be kept at the position from which the craft is normally navigated.

14.13 Sources of energy

14.13.1 There shall be available at all times, while the craft is at sea, a supply of electrical energy sufficient to operate the radio installations and to charge any batteries used as part of a reserve source of energy for the radio installations.

14.13.2 Reserve and emergency sources of energy shall be provided on every craft to supply radio installations, for the purpose of conducting distress and safety radiocommunications, in the event of failure of the craft's main and emergency sources of electrical power. The reserve source of energy shall be capable of simultaneously operating the VHF radio installation required by 14.7.1.1 and, as appropriate for the sea area or sea areas for which the craft is equipped, either the MF radio installation required by 14.9.1.1, the MF/HF radio installation required by 14.10.2.1 or 14.11.1 or the ship earth station required by 14.10.1.1 and any of the additional loads mentioned in 14.13.5 and 14.13.8 for a period of at least 1 h.

(TSFS 2023:58)

14.13.3 The reserve source of energy shall be independent of the propelling power of the craft and the craft's electrical system.

14.13.4 Where, in addition to the VHF radio installation, two or more of the other radio installations referred to in 14.13.2 can be connected to the reserve source or sources of energy, they shall be capable of simultaneously supplying, for the period specified in 14.13.2, the VHF radio installation and:

- .1 all other radio installations which can be connected to the reserve source of energy at the same time; or
- .2 whichever of the radio installations will consume the most power, if only one of the other radio installations can be connected to the reserve source of energy at the same time as the VHF radio installation.

14.13.5 The reserve source of energy may be used to supply the electrical lighting required by 14.6.2.4.

14.13.6 Where a reserve source of energy consists of a rechargeable accumulator battery or batteries:

- .1 a means of automatically charging such batteries shall be provided which shall be capable of recharging them to minimum capacity requirements within 10 h; and

- .2 the capacity of the battery or batteries shall be checked, using an appropriate method⁷³ at intervals not exceeding 12 months, when the craft is not at sea.

14.13.7 The siting and installation of accumulator batteries which provide a reserve source of energy shall be such as to ensure:

- .1 the highest degree of service;
- .2 a reasonable lifetime;
- .3 reasonable safety;
- .4 that the battery temperatures remain within the manufacturer's specifications whether under charge or idle; and
- .5 that when fully charged, the batteries will provide at least the minimum required hours of operation under all weather conditions.

14.13.8 If an uninterrupted input of information from the craft's navigational or other equipment to a radio installation required by this chapter is needed to ensure its proper performance, including the navigation receiver referred to in 14.18, means shall be provided to ensure the continuous supply of such information in the event of failure of the craft's main or emergency source of electrical power.

14.14 Performance standards

14.14.1 All equipment to which this chapter applies shall be of a type approved by the Administration. Such equipment shall conform to appropriate performance standards not inferior to those adopted by the Organization⁷⁴.

⁷³ One method of checking the capacity of an accumulator battery is to fully discharge and recharge the battery, using normal operating current and period (e.g. 10 h). Assessment of the charge condition can be made at any time, but it should be done without significant discharge of the battery when the craft is at sea.

⁷⁴ Refer to the following resolutions adopted by the Organization:

- .1 Resolution A.525(13): Performance Standards for Narrow-Band Direct-Printing Telegraph Equipment for the Reception of Navigational and Meteorological Warnings and Urgent Information to Ships.
- .2 Resolution A.694(17): General Requirements for Shipborne Radio Equipment Forming Part of the Global Maritime Distress and Safety System (GMDSS) and for Electronic Navigational Aids.
- .3 Resolution A.808(19): Performance Standards for Ship Earth Stations Capable of Two-Way Communications, and resolution A.570(14), Type Approval of Ship Earth Stations.

14.15 Maintenance requirements

14.15.1 Equipment shall be so designed that the main units can be replaced readily without elaborate recalibration or readjustment.

-
- .4 Resolutions A.803(19) and MSC.68(68), annex 1: Performance Standards for Shipborne VHF Radio installations Capable of Voice Communication and Digital Selective Calling.
 - .5 Resolutions A.804(19) and MSC.68(68), annex 2: Performance Standards for Shipborne MF Radio Installations Capable of Voice Communication and Digital Selective Calling.
 - .6 Resolutions A.806(19) and MSC.68(68), annex 3: Performance Standards for Shipborne MF/HF Radio Installations Capable of Voice Communication, Narrow-Band Direct Printing and Digital Selective Calling.
 - .7 Resolutions A.810(19) and MSC.56(66): Performance Standards for Float-Free Satellite Emergency Position-Indicating Radio Beacons (EPIRBs) Operating on 406 MHz (see also Assembly resolution A.696(17): Type Approval of Satellite Emergency Position-Indicating Radio Beacons (EPIRBs) Operating in the COSPAS-SARSAT System).
 - .8 Resolution A.802(19): Performance Standards for Survival Craft Radar Transponders for Use in Search and Rescue Operations.
 - .9 Resolution A.805(19): Performance Standards for Float-Free VHF Emergency Position-Indicating Radio Beacons.
 - .10 Resolutions A. 807(19) and MSC.68(68), annex 4: Performance Standards for Inmarsat Standard-C Ship Earth Stations Capable of Transmitting and Receiving Direct-Printing Communications, and resolution A.570(14), Type Approval of Ship Earth Stations.
 - .11 Resolution A.664(16): Performance Standards for Enhanced Group Call Equipment.
 - .12 Resolution A.812(19): Performance Standards for Float-Free Satellite Emergency Position-indicating Radio Beacons Operating Through the Geostationary Inmarsat Satellite System on 1.6 GHz.
 - .13 Resolution A.662(16): Performance Standards for Float-Free Release and Activation Arrangements for Emergency Radio Equipment.
 - .14 Resolution A.699(17): System Performance Standard for the Promulgation and Co-ordination of Maritime Safety Information Using High-Frequency Narrow-Band Direct Printing.
 - .15 Resolution A.700(17): Performance Standards for Narrow-Band Direct-Printing Telegraph Equipment for the Reception of Navigational and Meteorological Warnings and Urgent Information to Ships (MSI) by HF.
 - .16 Resolution MSC.80(70): Recommendation on Performance Standards for on-scene (Aeronautical) Portable Two-Way VHF Radiotelephone Apparatus.

14.15.2 Where applicable, equipment shall be so constructed and installed that it is readily accessible for inspection and on-board maintenance purposes.

14.15.3 Adequate information shall be provided to enable the equipment to be properly operated and maintained, taking into account the recommendations of the Organization⁷⁵.

14.15.4 Adequate tools and spares shall be provided to enable equipment to be maintained.

14.15.5 The Administration shall ensure that radio equipment required by this chapter is maintained to provide the availability of the functional requirements specified in 14.5 and to meet the recommended performance standards of such equipment.

14.15.6 On craft engaged on voyages in sea areas A1 and A2, the availability shall be ensured by using such methods as duplication of equipment, shore-based maintenance or at-sea electronic maintenance capability, or a combination of these, as may be approved by the Administration.

14.15.7 On craft engaged on voyages in sea areas A3 and A4, the availability shall be ensured by using a combination of at least two methods, such as duplication of equipment, shore-based maintenance or at-sea electronic maintenance capability, as may be approved by the Administration, taking into account the recommendations of the Organization⁷⁶.

14.15.8 However, for craft operating solely between ports where adequate facilities for shore-based maintenance of the radio installations are available and provided no journey between two such ports exceeds six hours, then the Administration may exempt such craft from the requirement to use at least two maintenance methods. For such craft at least one maintenance method shall be used.

14.15.9 While all reasonable steps shall be taken to maintain the equipment in efficient working order to ensure compliance with all the functional requirements specified in 14.5, malfunction of the equipment for providing the general radiocommunications, required by 14.8, shall not be considered as making a craft unseaworthy or as a reason for delaying the

⁷⁵ Refer to the Recommendation on General Requirements for Shipborne Radio Equipment Forming Part of the Global Maritime Distress and Safety System (GMDSS) and for Electronic Navigational Aids, adopted by the Organization by resolution A.694(17).

⁷⁶ Administrations should take account of the Radio Maintenance Guidelines for the Global Maritime Distress and Safety System (GMDSS) related to Sea Areas A3 and A4, adopted by the Organization by resolution A.702(17).

craft in ports where repair facilities are not readily available, provided the craft is capable of performing all distress and safety functions.

14.15.10 Satellite EPIRBs on all craft shall be:

- .1 annually tested for all aspects of operational efficiency, with special emphasis on checking the emission on operational frequencies, coding and registration, at intervals within 3 months before the expiry date, or 3 months before or after the anniversary date, of the High-Speed Craft Safety Certificate;
The test may be conducted on board the craft or at an approved testing station; and
 - .1 on passenger craft, within 3 months before the expiry date of the High-Speed Craft Safety Certificate; and
 - .2 on cargo craft, within 3 months before the expiry date, or 3 months before or after the anniversary date, of the High-Speed Craft Safety Certificate;

The test may be conducted on board the craft or at an approved testing station; and
- .2 subject to maintenance at intervals not exceeding five years, to be performed at an approved shore-based maintenance facility.

(TSFS 2023:58)

14.16 Radio personnel

14.16.1 Every craft shall carry personnel qualified for distress and safety radiocommunication purposes to the satisfaction of the Administration. The personnel shall be holders of certificates specified in the Radio Regulations as appropriate, any one of whom shall be designated to have primary responsibility for radiocommunications during distress incidents.

14.16.2 In passenger craft, at least one person qualified in accordance with sub-paragraph .1 shall be assigned to perform only radio-communication duties during distress incidents.

14.17 Radio records

A record shall be kept, to the satisfaction of the Administration and as required by the Radio Regulations, of all incidents connected with the radiocommunication service which appear to be of importance to safety of life at sea.

14.18 Position-updating

All two-way communication equipment carried on board craft to which this chapter applies which is capable of automatically including the craft's position in the distress alert shall be automatically provided with this information from an internal or external navigation receiver, if either is installed. If such a receiver is not installed, the craft's position and the time that position was correct shall be manually updated at intervals not exceeding four hours, while the craft is underway, so that it is always ready for transmission by the equipment.

CHAPTER 15

Operating Compartment Layout

15.1 Definitions

15.1.1 "Operating area" is the operating compartment and those parts of the craft on both sides of, and close to, the operating compartment which extend to the craft's side.

15.1.2 "Workstation" is a position at which one or several tasks constituting a particular activity are carried out.

15.1.3 "Docking workstation" is a place equipped with necessary means for docking the craft.

15.1.4 "Primary controls" are all control equipment necessary for the safe operation of the craft when it is under way, including those required in an emergency situation.

15.2 General

The design and layout of the compartment from which the crew operate the craft shall be such as to permit operating crew members to perform their duties in a correct manner without unreasonable difficulty, fatigue or concentration, and to minimize the likelihood of injury to operating crew members in both normal and emergency conditions.

15.3 Field of vision from the operating compartment

15.3.1 The operating station shall be placed above all other superstructures so that the operating crew are able to gain a view all round the horizon from the navigating workstation. Where it is impractical to meet the requirements of this paragraph from a single navigating workstation, the operating station shall be designed so that an all-round view of the horizon is obtained by using two navigating workstations combined or by any other means to the satisfaction of the Administration.

15.3.2 Blind sectors shall be as few and as small as possible, and not adversely affect the keeping of a safe look-out from the operating station. If stiffeners between windows are to be covered, this shall not cause further obstruction inside the wheelhouse.

15.3.3 The total arc of blind sectors from right ahead to 22.5° abaft the beam on either side shall not exceed 20°. Each individual blind sector shall not exceed 5°. The clear sector between two blind sectors shall not be less than 10°.

15.3.4 Where it is considered necessary by the Administration, the field of vision from the navigating workstation shall permit the navigators from this position to utilize leading marks astern of the craft for track monitoring.

15.3.5 The view of the sea surface from the operating station, when the navigators are seated, shall not be obscured by more than one craft length forward of the bow to 90° on either side irrespective of the craft's draught, trim and deck cargo.

15.3.6 The field of vision from the docking workstation, if remote from the operating station, shall permit one navigator to safely manoeuvre the craft to a berth.

15.4 Operating compartment

15.4.1 The design and arrangement of the operating compartment, including location and layout of the individual workstations, shall ensure the required field of vision for each function.

15.4.2 The craft's operating compartment shall not be used for purposes other than navigation, communications and other functions essential to the safe operation of the craft, its engines, passengers and cargo.

15.4.3 The operating compartment shall be provided with an integrated operating station for command, navigation, manoeuvring and communication and so arranged that it can accommodate those persons required to navigate the craft safely.

15.4.4 The arrangement of equipment and means for navigation, manoeuvring, control, communication and other essential instruments shall be located sufficiently close together to enable both the officer in charge and any assisting officer to receive all necessary information and to use the equipment and controls, as required, while they are seated. If necessary, the equipment and means serving these functions shall be duplicated.

15.4.5 If a separate workstation for supervision of engine performance is placed in the operating compartment, the location and use of this workstation shall not interfere with the primary functions to be performed in the operating station.

15.4.6 The location of the radio equipment shall not interfere with the primary navigational functions in the operating station.

15.4.7 The design and layout of the compartment from which the crew operate the craft and the relative positions of the primary controls shall be assessed against the essential operational manning level. Where minimum manning levels are proposed, the design and layout of the primary and communication controls shall form an integrated operational and emergency control centre from which the craft can be controlled under all operational and emergency events by the operating crew without the necessity for any crew member to vacate the compartment.

15.4.8 The relative positions of the primary controls and the seats shall be such that each operating crew member, with the seat suitably adjusted and without prejudicing compliance with 15.2, can:

- .1 without interference, produce full and unrestricted movement of each control both separately and with all practical combinations of movement of other controls; and
- .2 at all workstations, exert adequate control forces for the operation to be performed.

15.4.9 When a seat at a station from which the craft may be operated has been adjusted so as to suit the occupant, subsequent change of seat position to operate any control shall not be acceptable.

15.4.10 In craft where the Administration considers the provision of a safety belt necessary for use by the operating crew, it shall be possible for those operating crew members, with their safety belts correctly worn, to comply with 15.4.4 except in respect of controls which it can be shown will only be required on very rare occasions and which are not associated with the need for safety restraint.

15.4.11 The integrated operating station shall contain equipment which provides relevant information to enable the officer in charge and any assisting officer to carry out navigational and safety functions safely and efficiently.

15.4.12 Adequate arrangements shall be made to prevent passengers from distracting the attention of the operating crew.

15.5 Instruments and chart table

15.5.1 Instruments, instrument panels and controls shall be permanently mounted in consoles or other appropriate places, taking into account operation, maintenance and environmental conditions. However,

this shall not prevent the use of new control or display techniques, provided the facilities offered are not inferior to recognized standards.

15.5.2 All instruments shall be logically grouped according to their functions. In order to reduce to a minimum the risk of confusion, instruments shall not be rationalized by sharing functions or by inter-switching.

15.5.3 Instruments required for use by any member of the operating crew shall be plainly visible and easily read:

- .1 with minimum practicable deviation from his normal seating position and line of vision; and
- .2 with the minimum risk of confusion under all likely operating conditions.

15.5.4 Instruments essential for the safe operation of the craft shall be clearly marked with any limitation if this information is not otherwise clearly presented to the operating crew. The instrument panels forming the emergency control for the launching of liferafts and the monitoring of the fire-fighting systems shall be in separate and clearly defined positions within the operating area.

15.5.5 The instruments and controls shall be provided with means for screening and dimming in order to minimize glare and reflections and prevent them being obscured by strong light.

15.5.6 The surfaces of console tops and instruments shall have dark glare-free colours.

15.5.7 Instruments and displays providing visual information to more than one person shall be located for easy viewing by all users concurrently. If this is not possible, the instrument or display shall be duplicated.

15.5.8 If considered necessary by the Administration, the operating compartment shall be provided with a suitable table for chart work. There shall be facilities for lighting the chart. Chart-table lighting shall be screened.

15.6 Lighting

15.6.1 A satisfactory level of lighting shall be available to enable the operating personnel to adequately perform all their tasks both at sea and in port, by day and night. There shall be only a limited reduction in the illumination of essential instruments and controls under likely system fault conditions.

15.6.2 Care shall be taken to avoid glare and stray image reflection in the operating area environment. High contrast in brightness between work area and surroundings shall be avoided. Non-reflective or matt surfaces shall be used to reduce indirect glare to a minimum.

15.6.3 A satisfactory degree of flexibility within the lighting system shall be available to enable the operating personnel to adjust the lighting intensity and direction as required in the different areas of the operating compartment and at individual instruments and controls.

15.6.4 Red light shall be used to maintain dark adaptation whenever possible in areas or on items of equipment requiring illumination in the operational mode, other than the chart table.

15.6.5 During hours of darkness, it shall be possible to discern displayed information and control devices.

15.6.6 Reference is made to additional requirements on lighting in 12.7 and 12.8.

15.7 Windows

15.7.1 Divisions between windows, located in the front, on the sides and in the doors, shall be kept to a minimum. No division shall be installed immediately forward of the operating stations.

15.7.2 Administrations shall be satisfied that a clear view through the operating compartment windows is provided at all times regardless of weather conditions. The means provided for maintaining the windows in a clear condition shall be so arranged that no reasonably probable single failure can result in a reduction of the cleared field of vision such as to interfere seriously with the ability of the operating crew to continue the operation and bring the craft to rest.

15.7.3 Arrangements shall be provided so that the forward view from operating stations is not adversely affected by solar glare. Neither polarized nor tinted window glass shall be fitted.

15.7.4 Operating compartment windows shall be angled to reduce unwanted reflection.

15.7.5 The windows shall be made of material which will not break into dangerous fragments if fractured.

15.8 Communication facilities

15.8.1 Such means as are necessary shall be provided to enable the crew to communicate between, and have access to, each other and with other occupants of the craft in both normal and emergency conditions.

15.8.2 Means to communicate between the operating compartment and spaces containing essential machinery, including any emergency steering position, irrespective of whether the machinery is remotely or locally controlled, shall be provided.

15.8.3 Means for making public address and safety announcements from control stations to all areas to which passengers and crew have access shall be provided.

15.8.4 Provisions shall be made for means to monitor, receive and transmit radio safety messages at the operating compartment.

15.9 Temperature and ventilation

The operating compartment shall be equipped with adequate temperature and ventilation control systems.

15.10 Colours

The surface materials inside the operating compartment shall have a suitable colour and finish to avoid reflections.

15.11 Safety measures

The operating area shall be free of physical hazard to the operating personnel and have non-skid flooring in dry and wet conditions and adequate handrails. Doors shall be fitted with devices to prevent them moving, whether they are open or closed.

CHAPTER 16

Stabilization Systems

16.1 Definitions

16.1.1 "Stabilization control system" is a system intended to stabilize the main parameters of the craft's attitude: heel, trim, course and height and control the craft's motions: roll, pitch, yaw and heave. This term excludes devices not associated with the safe operation of the craft, e.g. motion-reduction or ride-control systems.

The main elements of a stabilization control system may include the following:

- .1 devices such as rudders, foils, flaps, skirts, fans, water jets, tilting and steerable propellers, pumps for moving fluids;
- .2 power drives actuating stabilization devices; and
- .3 stabilization equipment for accumulating and processing data for making decisions and giving commands such as sensors, logic processors and automatic safety control.

16.1.2 "Self-stabilization" of the craft is stabilization ensured solely by the craft's inherent characteristics.

16.1.3 "Forced stabilization" of the craft is stabilization achieved by:

- .1 an automatic control system; or
- .2 a manually assisted control system; or
- .3 a combined system incorporating elements of both automatic and manually assisted control systems.

16.1.4 "Augmented stabilization" is a combination of self-stabilization and forced stabilization.

16.1.5 "Stabilization device" means a device as enumerated in 16.1.1.1 with the aid of which forces for controlling the craft's position are generated.

16.1.6 "Automatic safety control" is a logic unit for processing data and making decisions to put the craft into the displacement or other safe mode if a condition impairing safety arises.

16.2 General requirements

16.2.1 Stabilization systems shall be so designed that, in case of failure or malfunctioning of any one of the stabilization devices or equipment, it would be possible either to ensure maintaining the main parameters of the craft's motion within safe limits with the aid of working stabilization devices or to put the craft into the displacement or other safe mode.

16.2.2 In case of failure of any automatic equipment or stabilization device, or of its power drive, the parameters of craft motion shall remain within safe limits.

16.2.3 Craft fitted with an automatic stabilization system shall be provided with an automatic safety control unless the redundancy in the system provides equivalent safety. Where an automatic safety control is fitted, provision shall be made to override it and to cancel the override from the main operating station.

16.2.4 The parameters and the levels at which any automatic safety control gives the command to decrease speed and put the craft safely in the displacement or other safe mode shall take account of the safe values of heel, trim, yaw and combination of trim and draught appropriate to the particular craft and service; also to the possible consequences of power failure for propulsion, lift or stabilization devices.

16.2.5 The parameters and the degree of stabilization of the craft provided by the automatic stabilization system shall be satisfactory, having regard to the purpose and service conditions of the craft.

16.2.6 Failure mode and effect analysis shall include the stabilization system.

16.3 Lateral and height control systems

16.3.1 Craft fitted with an automatic control system shall be provided with an automatic safety control. Probable malfunctions shall have only minor effects on automatic control system operation and shall be capable of being readily counteracted by the operating crew.

16.3.2 The parameters and levels at which any automatic control system gives the command to decrease speed and put the craft safely into the displacement or other safe mode shall take account of the safety levels as given in section 2.4 of annex 3 and of the safe values of motions appropriate to the particular craft and service.

16.4 Demonstrations

16.4.1 The limits of safe use of any of the stabilization control system devices shall be based on demonstrations and a verification process in accordance with annex 9.

16.4.2 Demonstration in accordance with annex 9 shall determine any adverse effects upon safe operation of the craft in the event of an uncontrollable total deflection of any one control device. Any limitation on the operation of the craft as may be necessary to ensure that the redundancy or safeguards in the systems provide equivalent safety shall be included in the craft operating manual.

CHAPTER 17

Handling, Controllability and Performance

17.1 General

The operational safety of the craft in normal service conditions and in equipment failure situations of a craft to which this Code applies shall be documented and verified by full-scale tests, supplemented by model tests where appropriate, of the prototype craft. The objective of tests is to determine information to be included in the craft operating manual in relation to:

- .1 operating limitations;
- .2 procedures for operation of the craft within the limitations;
- .3 actions to be taken in the event of prescribed failure; and
- .4 limitations to be observed for safe operation subsequent to prescribed failures.

Operational information shall be available on board for guidance, or the craft shall have an instrument system for on-line check of operational performance which shall be approved by the Administration taking into account the standards for the processing and presentation of measurements developed by the Organization. As a minimum, the system shall measure accelerations in three axes close to the craft longitudinal centre of gravity.

17.2 Proof of compliance

17.2.1 The information on controllability and manoeuvrability which shall be contained in the craft operating manual shall include the characteristics under 17.5 as applicable, the list of parameters of the worst intended conditions affecting the controllability and manoeuvrability according to 17.6, information on safe maximum speeds as described in 17.9 and the performance data verified in accordance with annex 9.

17.2.2 The information on operating limitations which shall be contained in the route operational manual shall include the characteristics under 17.2.1, 17.5.4.1 and 17.5.4.2.

17.3 Weight and centre of gravity

Compliance with each of the handling, controllability and performance requirements shall be established for all combinations of weight and centre

of gravity position significant for the operational safety in the range of weights up to the maximum permissible weight.

17.4 Effect of failures

The effect of any likely failure in handling and control devices, services or components (e.g. power operation, power assistance, trimming and stability augmentation) shall be assessed in order that a safe level of craft operation can be maintained. Effects of failure identified as being critical according to annex 4 shall be verified in accordance with annex 9.

17.5 Controllability and manoeuvrability

17.5.1 Instructions to crew members shall be provided in the craft operating manual regarding required actions and craft limitations subsequent to prescribed failures.

17.5.2 It is necessary to ensure that the effort required to operate the controls in the worst intended conditions is not such that the person at the control will be unduly fatigued or distracted by the effort necessary to maintain the safe operation of the craft.

17.5.3 The craft shall be controllable and be capable of performing those manoeuvres essential to its safe operation up to the critical design conditions.

17.5.4.1 When determining the operating limitations of a craft, particular attention shall be paid to the following aspects during normal operation and during failures and subsequent to failures:

- .1** yawing;
- .2** turning;
- .3** automatic pilot and steering performance;
- .4** stopping in normal and emergency conditions;
- .5** stability in the non-displacement mode about three axes and in heave;
- .6** trim;
- .7** roll;
- .8** plough in;
- .9** lift power limitations;
- .10** broaching;
- .11** slamming; and
- .12** bow diving.

17.5.4.2 The terms in 17.5.4.1.2, .6, .7 and .11 are defined as follows:

- .1 "Turning" is the rate of change of direction of a craft at its normal maximum operating speed in specified wind and sea conditions.
- .2 "Plough in" is an involuntary motion involving sustained increase in drag of an air-cushion vehicle at speed, usually associated with partial collapse of the cushion system.
- .3 "Lift power limitations" are those limitations imposed upon the machinery and components which provide the lift.
- .4 "Slamming" is the water impact on the underside of the hull in the bow area of the craft.

17.6 Change of operating surface and mode

There shall be no unsafe change in the stability, controllability or attitude of the craft during transition from one type of operating surface or mode to another. Information on change in the behaviour characteristics of the craft during transition shall be available to the master.

17.7 Surface irregularities

Factors which limit the ability of the craft to operate over sloping ground and steps or discontinuities shall be determined, as applicable, and made available to the master.

17.8 Acceleration and deceleration

The Administration shall be satisfied that the worst likely acceleration or deceleration of the craft, due to any likely failure, emergency stopping procedures or other likely causes, would not hazard the persons on the craft.

17.9 Speeds

Safe maximum speeds shall be determined, taking account of the limitations from 4.3.1, modes of operation, wind force and direction and the effects of possible failures of any one lift or propulsion system over calm water, rough water and over other surfaces, as appropriate to the craft.

17.10 Minimum depth of water

The minimum depth of water and other appropriate information required for operations in all modes shall be determined.

17.11 Hard structure clearance

For amphibious craft, when cushion-borne, clearance of the lowest point of the hard structure above a hard flat surface shall be determined.

17.12 Night operation

The schedule of tests shall include sufficient operation to evaluate the adequacy of internal and external lighting and visibility under conditions of normal and emergency electrical power supply during service, cruising and docking manoeuvres.

CHAPTER 18

Operational Requirements

PART A - GENERAL

18.1 Craft operational control

18.1.1 The High-Speed Craft Safety Certificate, the Permit to Operate High-Speed Craft or certified copies thereof, and copies of the route operational manual, craft operating manual, and a copy of such elements of the maintenance manual as the Administration may require shall be carried on board.

18.1.2 The craft shall not be intentionally operated outside the worst intended conditions and limitations specified in the Permit to Operate High-Speed Craft, in the High-Speed Craft Safety Certificate, or in documents referred to therein.

18.1.3 The Administration shall issue a Permit to Operate High-Speed Craft when it is satisfied that the operator has made adequate provisions from the point of view of safety generally, including the following matters specifically, and shall revoke the Permit to Operate if such provisions are not maintained to its satisfaction:

- .1** the suitability of the craft for the service intended, having regard to the safety limitations and information contained in the route operational manual;
- .2** the suitability of the operating conditions in the route operational manual;
- .3** the arrangements for obtaining weather information on the basis of which the commencement of a voyage may be authorized;
- .4** provision in the area of operation of a base port having functions and facilities in accordance with the requirements of this Code;
- .5** the designation of the person responsible for decisions to cancel or delay a particular voyage, e.g. in the light of the weather information available;
- .6** sufficient crew complement required for operating the craft, deploying and manning survival craft, the supervision of passengers, vehicles and cargo in both normal and emergency conditions as defined in the Permit to Operate. The crew complement shall be such

- that two officers are on duty in the operating compartment when the craft is under way, one of whom may be the master;
- .7 crew qualifications and training, including competence in relation to the particular type of craft and service intended, and their instructions in regard to safe operational procedures;
 - .8 restrictions with regard to working hours, rostering of crews and any other arrangements to prevent fatigue, including adequate rest periods;
 - .9 the training of crew in craft operation and emergency procedures;
 - .10 the maintenance of crew competence in regard to operation and emergency procedures;
 - .11 safety arrangements at terminals and compliance with any existing safety arrangements, as appropriate;
 - .12 traffic control arrangements and compliance with any existing traffic control, as appropriate;
 - .13 restrictions and/or provisions relating to position fixing and to operation by night or in restricted visibility, including the use of radar and/or other electronic aids to navigation, as appropriate;
 - .14 additional equipment which may be required, due to the specific characteristics of the service intended, for example, night operation;
 - .15 communication arrangements between craft, coast radio stations, base ports radio stations, emergency services and other ships, including radio frequencies to be used and watch to be kept;
 - .16 the keeping of records to enable the Administration to verify:
 - .16.1 that the craft is operated within the specified parameters,
 - .16.2 the observance of emergency and safety drills/procedures;
 - .16.3 the hours worked by the operating crew;
 - .16.4 the number of passengers on board;
 - .16.5 compliance with any law to which the craft is subject;
 - .16.6 craft operations; and
 - .16.7 maintenance of the craft and its machinery in accordance with approved schedules;

- .17 arrangements to ensure that equipment is maintained in compliance with the Administration's requirements, and to ensure co-ordination of information as to the serviceability of the craft and equipment between the operating and maintenance elements of the operator's organization;
- .18 the existence and use of adequate instructions regarding:
 - .18.1 loading of the craft so that weight and centre of gravity limitations can be effectively observed and cargo is, when necessary, adequately secured;
 - .18.2 the provision of adequate fuel reserves;
 - .18.3 action in the event of reasonable foreseeable emergencies; and
- .19 provision of contingency plans by operators for foreseeable incidents including all land-based activities for each scenario. The plans shall provide operating crews with information regarding search and rescue (SAR) authorities and local administrations and organizations which may complement the tasks undertaken by crews with the equipment available to them⁷⁷.

18.1.4 The Administration shall determine the maximum allowable distance from a base port or place of refuge after assessing the provisions made under 18.1.3.

18.1.5 The master shall ensure that an effective system of supervision and reporting of the closing and opening of accesses referred to in 2.2.4.2 and 2.2.4.3 is implemented.

18.2 Craft documentation

The company shall ensure that the craft is provided with adequate information and guidance in the form of technical manual(s) to enable the craft to be operated and maintained safely. The technical manual(s) shall consist of a route operational manual, craft operating manual, training manual, maintenance manual and servicing schedule. Arrangements shall be made for such information to be updated as necessary.

18.2.1 Craft operating manual

⁷⁷ Refer to the IMO Search and Rescue Manual (IMOSAR), adopted by the Organization by resolution A.439(XI), and Use of Radar Transponders for Search and Rescue Purposes, adopted by resolution A.530(13).

The craft operating manual shall contain at least the following information:

- .1 leading particulars of the craft;
- .2 description of the craft and its equipment;
- .3 procedures for checking the integrity of buoyancy compartments;
- .4 details arising from compliance with the requirements of chapter 2 likely to be of direct practical use to the crew in an emergency;
- .5 damage control procedures (e.g. information in a damage control plan required by SOLAS regulation II-1/23 or II-1/25-8.2, as appropriate);
- .6 description and operation of machinery systems;
- .7 description and operation of auxiliary systems;
- .8 description and operation of remote control and warning systems;
- .9 description and operation of electrical equipment;
- .10 loading procedures and limitations, including maximum operational weight, centre of gravity position and distribution of load, including any cargo or car securing arrangement and procedures depending on operational restrictions or damaged conditions. Such arrangement and procedures shall not be included as a separate Cargo Securing Manual as required by chapter VI of the Convention;
- .11 description and operation of fire-detection and fire-extinguishing equipment;
- .12 drawings indicating the structural fire protection arrangements;
- .13 description and operation of radio equipment and navigational aids;
- .14 information regarding the handling of the craft as determined in accordance with chapter 17;
- .15 maximum permissible towing speeds and towing loads, where applicable;
- .16 procedure for dry-docking or lifting, including limitations;
- .17 in particular, the manual shall provide information, in clearly defined chapters, relating to:
 - .17.1 indication of emergency situations or malfunctions jeopardizing safety, required actions to be taken and any consequential

- restrictions on operation of the craft or its machinery;
- .17.2 evacuation procedures;
- .17.3 the worst intended conditions;
- .17.4 limiting values of all machinery parameters requiring compliance for safe operation.

In regard to information on machinery or system failures, data shall take into account the results of any FMEA reports developed during the craft design.

18.2.2 Route operational manual

The route operational manual shall include at least the following information:

- .1 evacuation procedures;
- .2 operating limitations, including the worst intended conditions;
- .3 procedures for operation of the craft within the limitations of .2;
- .4 the elements of applicable contingency plans for primary and secondary rescue assistance in the case of foreseeable incidents, including land-based arrangements and activities for each incident;
- .5 arrangements for obtaining weather information;
- .6 identification of the "base port(s)";
- .7 identification of the person responsible for decisions to cancel or delay voyages;
- .8 identification of crew complement, functions and qualifications;
- .9 restrictions on working hours of crew;
- .10 safety arrangements at terminals;
- .11 traffic control arrangements and limitations, as appropriate;
- .12 specific route conditions or requirements relating to position fixing, operations by night and in restricted visibility, including the use of radar or other electronic aids to navigation; and
- .13 communication arrangements between craft, coast radio stations, base ports radio stations, emergency services and other ships, including radio frequencies to be used and watch to be kept.

18.2.3 Training manual

The training manual, which may comprise several volumes, shall contain instructions and information, in easily understood terms, illustrated wherever possible, on evacuation, fire and damage control appliances and systems and on the best methods of survival. Any part of such information may be provided in the form of audio-visual aids in lieu of the manual. Where appropriate, the contents of the training manual may be included in the craft operating manual. The following shall be explained in detail:

- .1 donning lifejackets and immersion suits, as appropriate;
- .2 muster at the assigned stations;
- .3 boarding, launching and clearing the survival craft and rescue boats;
- .4 method of launching from within the survival craft;
- .5 release from launching appliances;
- .6 methods and use of devices for protection in launching areas, where appropriate;
- .7 illumination in launching areas;
- .8 use of all survival equipment;
- .9 use of all detection equipment;
- .10 with the assistance of illustrations, the use of radio life-saving appliances;
- .11 use of drogues;
- .12 use of engine and accessories;
- .13 recovery of survival craft and rescue boats, including stowage and securing;
- .14 hazards of exposure and the need for warm clothing;
- .15 best use of the survival craft facilities in order to survive;
- .16 methods of retrieval, including the use of helicopter rescue gear (slings, baskets, stretchers), breeches-buoy and shore life-saving apparatus and craft's line-throwing apparatus;
- .17 all other functions contained in the muster list and emergency instructions;
- .18 instructions for emergency repair of the life-saving appliances;
- .19 instructions in the use of fire protection and fire-extinguishing appliances and systems;
- .20 guidelines for use of firefighter's outfit in a fire, if fitted;
- .21 use of alarms and communications associated with fire safety;

- .22 methods for surveying damage;
- .23 use of damage control appliances and systems, including operation of watertight doors and bilge pumps; and
- .24 for passenger craft, control of and communication with passengers in an emergency.

18.2.4 Maintenance and servicing manual/system

The craft maintenance and servicing manual/system shall contain as a minimum:

- .1 detailed, illustrated description of all craft structure, machinery installations and all installed equipment and systems required for safe operation of the craft;
- .2 specifications and quantities of all replenishable fluids and of structural materials which may be required for repairs;
- .3 operational limitations of machinery in terms of values of parameters, vibration and consumption of replenished fluids;
- .4 limitations of wear of structure or machinery components, including lives of components requiring calendar or operating time replacement;
- .5 detailed description of procedures, including any safety precautions to be taken or special equipment required, to remove and install main and auxiliary machinery, transmissions, propulsion and lift devices and flexible structure components;
- .6 test procedures to be followed subsequent to replacement of machinery or system components or for malfunction diagnosis;
- .7 procedure for lifting or dry-docking the craft, including any weight or attitude limitations;
- .8 procedure for weighing the craft and establishing the position
- .9 where craft may be dismantled for transportation, instructions shall be provided for dismantling, transport and re-assembly;

- .10 a servicing schedule, included in the maintenance manual or published separately, detailing the routine servicing and maintenance operations required to maintain the operational safety of the craft and its machinery and systems.

18.2.5 Information on passengers

18.2.5.1 All persons on board passenger craft shall be counted prior to departure.

18.2.5.2 Details of persons who have declared a need for special care or assistance in emergency situations shall be recorded and communicated to the master prior to departure.

18.2.5.3 The names and gender of all persons on board, distinguished between adults, children and infants shall be recorded for search and rescue purposes.

18.2.5.4 The information required by 18.2.5.1, 18.2.5.2 and 18.2.5.3 shall be kept ashore and made readily available to search and rescue services when needed.

18.2.5.5 The Administration may exempt from the requirements of 18.2.5.3 passenger craft operating on voyages having a duration of 2 h or less between each port of call.

18.3 Training and qualifications

18.3.1 The level of competence and the training considered necessary in respect of the master and each crew member shall be laid down and demonstrated in the light of the following guidelines to the satisfaction of the company in respect of the particular type and model of craft concerned and the service intended. More than one crew member shall be trained to perform all essential operational tasks in both normal and emergency situations.

18.3.2 The Administration shall specify an appropriate period of operational training for the master and each member of the crew and, if necessary, the periods at which appropriate retraining shall be carried out.

18.3.3 The Administration shall issue a type rating certificate to the master and all officers having an operational role following an appropriate period of operational/simulator training and on the conclusion of an examination including practical test commensurate with the operational tasks on board the particular type and model of craft concerned and the route followed. The type rating training shall cover at least the following items:

- .1 knowledge of all on-board propulsion and control systems, including communication and navigational equipment, steering, electrical, hydraulic and pneumatic systems and bilge and fire pumping;
- .2 the failure mode of the control, steering and propulsion systems and proper response to such failures;
- .3 handling characteristics of the craft and the limiting operational conditions;
- .4 bridge communication and navigation procedures;
- .5 intact and damage stability and survivability of the craft in damage condition;
- .6 location and use of the craft's life-saving appliances, including survival craft equipment;
- .7 location and use of escapes in the craft and the evacuation of passengers;
- .8 location and use of fire protection and fire-extinguishing appliances and systems in the event of fire on board;
- .9 location and use of damage control appliances and systems, including operation of watertight doors and bilge pumps;
- .10 cargo and vehicle stowage and securing systems;
- .11 methods for control of and communication with passengers in an emergency; and
- .12 location and use of all other items listed in the training manual.

18.3.4 The type rating certificate for a particular type and model of craft should only be valid for service on the route to be followed when it is so endorsed by the Administration following the completion of a practical test over that route.

18.3.5 The type rating certificate shall be re-validated every two years and the Administration shall lay down the procedures for re-validation.

18.3.6 All crew members shall receive instructions and training, as specified in 18.3.3.6 to 18.3.3.12.

18.3.7 The Administration shall specify standards of physical fitness and frequency of medical examinations, having regard to the route and craft concerned.

18.3.8 The Administration of the country in which the craft is to operate, if other than the flag State, shall be satisfied with the training, experience and qualifications of the master and each crew member. A valid certificate of competency or a valid license appropriately endorsed, in accordance with the provisions of the International Convention on Standards of Training,

Certification and Watchkeeping (STCW), 1978 as amended, held by the master or crew member, shall be acceptable as evidence of satisfactory training and qualification to the Administration of the country in which the craft is to operate.

18.4 Manning of survival craft and supervision

The company and the master shall ensure that:

- .1 a sufficient number of trained persons are on board for mustering and assisting untrained persons;
- .2 a sufficient number of crew members, who may be deck officers or certificated persons, are on board for operating the survival craft, rescue boats and launching arrangements required for abandonment by the total number of persons on board;
- .3 a deck officer or certificated person is placed in charge of each survival craft to be used recognizing, however, that the Administration, having due regard to the nature of the voyage, the number of persons on board and the characteristics of the craft, may permit a deck officer, certificated person or persons practised in the handling and operation of liferafts to be placed in charge of each liferaft or group of liferafts;
- .4 the person in charge of survival craft has a list of the survival craft crew and sees that those crew members are acquainted with their duties;
- .5 every rescue boat and lifeboat has a person assigned who is capable of operating the engine and carrying out minor adjustments; and
- .6 the persons referred to in .1 to .3 are equitably distributed among the craft's survival craft.

18.5 Emergency instructions and drills

18.5.1 The company shall ensure that the emergency instructions and drills referred to in 18.5.1 to 18.5.10 are implemented, and the master shall be responsible for the enforcement of these instructions and drills on board. On or before departure, passengers shall be instructed in the use of lifejackets and the action to be taken in an emergency. The attention of the passengers shall be drawn to the emergency instructions required by 8.4.1 and 8.4.3.

18.5.2 Emergency fire and evacuation drills for the crew shall be held on board the craft at intervals not exceeding one week for passenger craft and one month for cargo craft.

18.5.3 Each member of each crew shall participate in at least one evacuation, fire and damage control drill per month.

18.5.4 Crew members with enclosed space entry or rescue responsibilities shall participate in an enclosed space entry and rescue drill, to be held on board the craft, at least once every two months. *(TSFS 2023:58)*

18.5.5 On-board drills shall, as far as practicable, be conducted to simulate an actual emergency. Such simulations shall include instruction and operation of the craft's evacuation, fire and damage control appliances and systems. *(TSFS 2023:58)*

18.5.6 On-board instruction and operation of the craft's evacuation, fire and damage control appliances and systems shall include appropriate cross-training of crew members. *(TSFS 2023:58)*

18.5.7 Emergency instructions including a general diagram of the craft showing the location of all exits, routes of evacuation, assigned assembly stations, emergency equipment, life-saving equipment and appliances and illustration of lifejacket donning shall be available to each passenger and crew member in appropriate languages. It shall be placed near each passenger and crew seat and conspicuously displayed at assembly stations and other passenger spaces. *(TSFS 2023:58)*

18.5.8 Records *(TSFS 2023:58)*

18.5.8.1 The date when musters are held, details of abandon craft drills and fire drills, drills of other life-saving appliances, enclosed space entry and rescue drills, and onboard training shall be recorded in such log-book as may be prescribed by the Administration. *(TSFS 2023:58)*

18.5.8.2 The master shall ensure, before the craft leaves the berth on any voyage, that a record is made of the time of the last closing of the accesses referred to 2.2.4.2 and 2.2.4.3. *(TSFS 2023:58)*

18.5.9 Evacuation drills *(TSFS 2023:58)*

18.5.9.1 Evacuation drill scenarios shall vary each week so that different emergency conditions are simulated. *(TSFS 2023:58)*

18.5.9.2 Each evacuation craft drill shall include: *(TSFS 2023:58)*

- .1** summoning of crew to assembly stations with the alarm required by 8.2.2.2 and ensuring that they are made aware of the order to abandon craft specified in the muster list;
- .2** reporting to stations and preparing for the duties described in the muster list;

- .3 checking that crew are suitably dressed;
- .4 checking that lifejackets are correctly donned;
- .5 operation of davits if any used for launching liferafts;
- .6 donning of immersion suits or thermal protective clothing by appropriate crew members;
- .7 testing of emergency lighting for mustering and abandonment; and
- .8 giving instructions in the use of the craft's life-saving appliances and in survival at sea.

18.5.9.3 Rescue boat drill

- .1 As far as is reasonable and practicable, rescue boats shall be launched each month as part of the evacuation drill, with their assigned crew aboard, and manoeuvred in the water. In all cases this requirement shall be complied with at least once every three months.
- .2 If rescue boat launching drills are carried out with the craft making headway, such drills shall, because of the dangers involved, be practised in sheltered waters only and under the supervision of an officer experienced in such drills⁷⁸.

(TSFS 2023:58)

18.5.9.4 Individual instructions may cover different parts of the craft's life-saving system, but all the craft's life-saving equipment and appliances shall be covered within any period of one month on passenger craft and two months on cargo craft. Each member of the crew shall be given instructions which shall include but not necessarily be limited to:

- .1 operation and use of the craft's inflatable liferafts;
- .2 problems of hypothermia, first-aid treatment of hypothermia and other appropriate first-aid procedures; and
- .3 special instructions necessary for use of the craft's life-saving appliances in severe weather and severe sea conditions.

(TSFS 2023:58)

⁷⁸ Refer to the Guidelines on training for the purpose of launching lifeboats and rescue boats from ships making headway through the water, adopted by the Organization by resolution A.624(15).

18.5.9.5 On-board training in the use of davit-launched liferafts shall take place at intervals of not more than four months on every craft fitted with such appliances. Whenever practicable, this shall include the inflation and lowering of a liferaft. This liferaft may be a special liferaft intended for training purposes only, which is not part of the craft's life-saving equipment. Such a special liferaft shall be conspicuously marked.

(TSFS 2023:58)

18.5.10 Fire drills *(TSFS 2023:58)*

18.5.10.1 Fire drill scenarios shall vary each week so that emergency conditions are simulated for different craft compartments. *(TSFS 2023:58)*

18.5.10.2 Each fire drill shall include:

- .1 summoning of crew to fire stations;
- .2 reporting to stations and preparing for the duties described in the muster list;
- .3 donning of firefighter's outfits;
- .4 operation of fire doors and fire dampers;
- .5 operation of fire pumps and fire-fighting equipment;
- .6 operation of communication equipment, emergency signals and general alarm;
- .7 operation of fire-detection system; and
- .8 instruction in the use of the craft's fire-fighting equipment and sprinkler and drencher systems, if fitted.

(TSFS 2023:58)

18.5.11 Damage control drills *(TSFS 2023:58)*

18.5.11.1 Damage control drill scenarios shall vary each week so that emergency conditions are simulated for different damage conditions.

(TSFS 2023:58)

18.5.11.2 Each damage control drill shall include:

- .1 summoning of crew to damage control stations;
- .2 reporting to stations and preparing for the duties described in the muster list;
- .3 operation of watertight doors and other watertight closures;
- .4 operation of bilge pumps and testing of bilge alarms and automatic bilge pump starting systems; and

- .5 instruction in damage survey, use of the craft damage control systems and passenger control in the event of an emergency.

(TSFS 2023:58)

18.5.12 Enclosed space entry and rescue drills *(TSFS 2023:58)*

18.5.12.1 Enclosed space entry and rescue drills should be planned and conducted in a safe manner, taking into account, as appropriate, the guidance provided in the recommendations developed by the Organization⁷⁹.

(TSFS 2023:58)

18.5.12.2 Each enclosed space entry and rescue drill shall include:

- .1 checking and use of personal protective equipment required for entry;
- .2 checking and use of communication equipment and procedures;
- .3 checking and use of instruments for measuring the atmosphere in enclosed spaces;
- .4 checking and use of rescue equipment and procedures; and
- .5 instructions in first aid and resuscitation techniques.

(TSFS 2023:58)

18.5.12.3 The risks associated with enclosed spaces and onboard procedures for safe entry into such spaces which should take into account, as appropriate, the guidance provided in recommendations developed by the Organization⁸⁰.

(TSFS 2023:58)

PART B - REQUIREMENTS FOR PASSENGER CRAFT

18.6 Type rating training

18.6.1 The company shall ensure that the type rating training is implemented. For all crew members, the type rating training shall cover the control and evacuation of passengers additionally to 18.3.5.

⁷⁹ Refer to the Revised Recommendations for entering enclosed spaces aboard ships, adopted by the Organization by resolution A.1050(27).

⁸⁰ Refer to the Revised Recommendations for entering enclosed spaces aboard ships, adopted by the Organization by resolution A.1050(27).

18.6.2 When a craft carries cargoes, the craft shall comply with the requirements of part C of this chapter in addition to this part.

18.7 Emergency instructions and drills

18.7.1 The company shall ensure that the emergency instructions are implemented, and the master shall be responsible for communicating the provisions of the emergency instructions to passenger upon boarding.

PART C - REQUIREMENTS FOR CARGO CRAFT

18.8 Type rating training

The company shall ensure that type rating training is implemented as provided in 18.3. For all crew members, the type rating training shall cover knowledge of cargo and vehicles storage area securement systems.

CHAPTER 19

Inspection and Maintenance Requirements

19.1 The Administration shall be satisfied with the operator's organization or any organization on which he may call in the maintenance of his craft and shall specify the scope of the duties which any part of the organization may carry out, having regard to the number and competence of its staff, facilities available, arrangements for calling on specialist assistance should it be necessary, record-keeping, communication and allocation of responsibilities.

19.2 The craft and equipment shall be maintained to the satisfaction of the Administration; in particular:

- .1** routine preventive inspection and maintenance shall be performed to a schedule approved by the Administration, which shall have regard at least in the first instance to the
- .2** in the performance of maintenance tasks, due regard shall be paid to maintenance manuals, service bulletins acceptable to the Administration and to any additional instructions of the Administration in this respect;
- .3** all modifications shall be recorded and their safety aspects investigated. Where it could have any effect on safety, the modification, together with its installation, shall be to the satisfaction of the Administration;
- .4** appropriate arrangements shall be provided for informing the master of the serviceability state of his craft and its equipment;
- .5** the duties of the operating crew in respect of maintenance and repairs and the procedure for obtaining assistance with repairs when the craft is away from the base port shall be clearly defined;
- .6** the master shall report to the maintenance organization any defects and repairs which are known to have occurred during operations;
- .7** records of defects and their correction shall be maintained and those defects of recurrent nature, or those which adversely affect craft or personal safety, shall be reported to the Administration.

19.3 The Administration shall be satisfied that arrangements are provided for ensuring adequate inspection, maintenance and recording of all life-saving appliances and distress signals carried.

ANNEX 1

**FORM OF HIGH-SPEED CRAFT SAFETY CERTIFICATE
AND RECORD OF EQUIPMENT**

HIGH-SPEED CRAFT SAFETY CERTIFICATE

This Certificate shall be supplemented by a Record of Equipment

(Official seal)

(State)

Issued under the provisions of the

INTERNATIONAL CODE OF SAFETY FOR HIGH-SPEED CRAFT,
2000
(resolution MSC.97(73))

under the authority of the Government of

.....
(full designation of the State)

by
*(full official designation of the competent person or
organization authorized by the Administration)*

*Particulars of craft**

Name of craft

Manufacturer's model and hull number

Distinctive number or letters

IMO number**

Port of registry

Gross tonnage

Sea areas in which the craft is certified to operate (paragraph 14.2.1)
.....

Design waterline corresponding to a height of below the reference line
at the longitudinal centre of flotation, and draughts at the draught marks of
..... forward and aft

* Alternatively, the particulars of the craft may be placed horizontally in boxes.

** In accordance with the IMO ship identification number scheme, adopted by the
Organization by resolution A.600(15).

The upper edge of the reference line is..... at (..... mm below uppermost deck at side)* (..... mm above the underside of keel)* at longitudinal centre of flotation.

Category category A passenger craft/category B passenger craft/cargo craft*

Craft type air-cushion vehicle/surface-effect ship/hydrofoil/monohull/-multihull/other (give detail)*

Date on which keel was laid or craft was at a similar stage of construction or on which a major conversion was commenced

THIS IS TO CERTIFY:

1 That the above-mentioned craft has been duly surveyed in accordance with the applicable provisions of the International Code of Safety for High-Speed Craft, 2000.

2 That the survey showed that the structure, equipment, fittings, radio station arrangements and materials of the craft and the condition thereof are in all respects satisfactory and that the craft complies with the relevant provisions of the Code.

3 That the life-saving appliances are provided for a total number of persons and no more as follows:
.....
.....

4 That, in accordance with 1.11 of the Code, the following equivalents have been granted in respect of the craft:

paragraph equivalent arrangement
.....

This certificate is valid until**

Completion date of the survey on which this certificate is based: .
.....
(dd/mm/yyyy)

Issued at
(Place of issue of certificate)

* Delete as appropriate.

** Insert the date of expiry as specified by the Administration in accordance with 1.8.4 of the Code. The day and the month of this date correspond to the anniversary date as defined in 1.4.3 of the Code, unless amended in accordance with 1.8.12.1 of the Code.

Endorsement to extend the Certificate if valid for less than 5 years where 1.8.8 of the Code applies

This craft complies with the relevant requirements of the Code, and this Certificate shall, in accordance with 1.8.8 of the Code, be accepted as valid until

Signed:

(Signature of authorized official)

Place:.....

Date:

.....
(Seal or stamp of authority, as appropriate)

Endorsement where the renewal survey has been completed and 1.8.9 of the Code applies

This craft complies with the relevant requirements of the Code, and this Certificate shall, in accordance with 1.8.9 of the Code, be accepted as valid until

Signed:

(Signature of authorized official)

Place:.....

Date:

.....
(Seal or stamp of authority, as appropriate)

Endorsement to extend the validity of the Certificate until reaching the port of survey where 1.8.10 of the Code applies

Signed:

(Signature of authorized official)

Place:.....

Date:

.....
(Seal or stamp of authority, as appropriate)

Endorsement for the advancement of the anniversary date where 1.8.12 of the Code applies

In accordance with 1.8.12 of the Code, the new anniversary date is

Signed:

(Signature of authorized official)

Place:.....

Date:

.....
(Seal or stamp of authority, as appropriate)

In accordance with 1.8.13 of the Code, the new anniversary date is

Signed:

(Signature of authorized official)

Place:.....

Date:

.....
(Seal or stamp of authority, as appropriate)

**RECORD OF EQUIPMENT FOR
HIGH-SPEED CRAFT SAFETY CERTIFICATE**

This Record shall be permanently attached to the
High-Speed Craft Safety Certificate

**RECORD OF EQUIPMENT FOR COMPLIANCE WITH THE
INTERNATIONAL CODE OF SAFETY
FOR HIGH-SPEED CRAFT, 2000**

1 Particulars of craft

Name of craft

Manufacturer's model and hull number

Distinctive number or letters

IMO number*

Category: category A passenger craft/category B passenger
craft/cargo craft**

Craft type: air-cushion vehicle, surface-effect ship, hydrofoil,
monohull, multihull, other
(give detail)**

Number of passengers for which certified

Minimum number of persons with required qualifications to operate the
radio installations

* In accordance with the IMO ship identification number scheme adopted by the
Organization by resolution A.600(15).

** Delete as appropriate.

2 Details of life-saving appliances

1	Total number of persons for which life-saving appliances are provided
2	Total number of lifeboats
2.1	Total number of persons accommodated by them
2.2	Number of partially enclosed lifeboats complying with section 4.5 of the LSA Code
2.3	Number of totally enclosed lifeboats complying with sections 4.6 and 4.7 of the LSA Code
2.4	Other lifeboats
2.4.1	Number
2.4.2	Type
3	Number of rescue boats
3.1	Number of rescue boats which are included in the total lifeboats shown above
4	Liferafts complying with sections 4.1 to 4.3 of the LSA Code for which suitable means of launching are provided
4.1	Number of liferafts
4.2	Number of persons accommodated by them
5	Open reversible liferafts (Annex 11 of the Code)
5.1	Number of liferafts
5.2	Number of persons accommodated by them

6	Number of Marine Evacuation System (MES)
6.1	Number of persons served by them
7	Number of lifebuoys
8	Number of lifejackets
8.1	Number suitable for adults
8.2	Number suitable for children
9	Immersion suits
9.1	Total number
9.2	Number of suits complying with the requirements for lifejackets
10	Number of anti-exposure suits
10.1	Total number
10.2	Number of suits complying with the requirements for lifejackets
11	Radio installations used in life-saving appliances
11.1	Number of radar transponders
11.2	Number of two-way VHF radiotelephone apparatus

3 Details of navigational systems and equipment

1.1	Magnetic compass
1.2	Transmitting heading device (THD)
1.3	Gyro-compass
2	Speed and distance measuring device
3	Echo-sounding device
4.1	9 GHz radar
4.2	Second radar (3 GHz/9 GHz*)
4.3	Automatic radar plotting aid (ARPA)/Automatic tracking aid (ATA)*
5	Receiver for global navigation satellite system/ Terrestrial navigation system/ Other means of position fixing*.**
6.1	Rate of turn indicator
6.2	Rudder angle indicator/Direction of steering thrust indicator*
7.1	Nautical charts/Electronic Chart Display and Information System (ECDIS)*
7.2	Back-up arrangements for ECDIS
7.3	Nautical publications
7.4	Back-up arrangement for nautical publications
8	Search light
9	Daylight signalling lamp
10	Night vision equipment
11	Means to show the mode of the propulsion systems
12	Automatic steering aid (Automatic pilot)
13	Radar reflector/ Other means*.**
14	Sound reception system
15	Automatic identification system (AIS)
16	Long-range identification and tracking system
17	Voyage data recorder (VDR)

* Delete as appropriate

** In case of “other means” they shall be specified

	Actual provision
1 Primary systems
1.1 VHF radio installation:
1.1.1 DSC encoder
1.1.2 DSC watch receiver
1.1.3 Radiotelephony
1.2 MF radio installation:
1.2.1 DSC encoder
1.2.2 DSC watch receiver
1.2.3 Radiotelephony
1.3 MF/HF radio installation:
1.3.1 DSC encoder
1.3.2 DSC watch receiver
1.3.3 Radiotelephony
1.3.4 Direct-printing radiotelegraphy
1.4 Inmarsat ship earth station
2 Secondary means of alerting
3 Facilities for reception of maritime safety information
3.1 NAVTEX receiver
3.2 EGC receiver
3.3 HF direct-printing radiotelegraph receiver
4 Satellite EPIRB
4.1 COSPAS-SARSAT
4.2 Inmarsat
5 VHF EPIRB
6 Ship's radar transponder
7 Two-way on-scene radiocommunications 121.5 MHz & 123.1 MHz

- 5 Methods used to ensure availability of radio facilities
 (paragraphs 14.15.6, 14.15.7 and 14.15.8 of the Code)
- 5.1 Duplication of equipment
- 5.2 Shore-based maintenance
- 5.3 At-sea maintenance capability

THIS IS TO CERTIFY that this Record is correct in all respects

Issued at

(Place of issue of the Record)

.....
(Date of issue)

.....
*(Signature of duly authorized official
 issuing the Record)*

.....
(Seal or stamp of the issuing authority, as appropriate)

ANNEX 2

FORM OF PERMIT TO OPERATE HIGH-SPEED CRAFT

PERMIT TO OPERATE HIGH-SPEED CRAFT

Issued under the provisions of the

INTERNATIONAL CODE OF SAFETY FOR HIGH-SPEED CRAFT,
2000
(resolution MSC.97(73))

- 1 Name of craft
- 2 Manufacturer's model and hull number
.....
- 3 Distinctive number or letters
- 4 IMO number*
- 5 Port of registry
- 6 Category of craft category A passenger craft/category B
 passenger craft/cargo craft**
- 7 Name of operator
- 8 Areas or routes of operation
- 9 Base port(s)
- 10 Maximum distance from place of refuge

* In accordance with the IMO ship identification number scheme, adopted by the Organization by resolution A.600(15).

** Delete as appropriate.

TSFS 2009:102

Bilaga 1

- 11 Number of:
- .1 passengers maximum permitted
 - .2 manning scale required

12 Worst intended conditions

.....

.....

13 Other operational restrictions

.....

.....

This permit confirms that the service mentioned above has been found to be in accordance with the general requirements of 1.2.2 to 1.2.7 of the Code.

THIS PERMIT is issued under the authority of the Government of

.....

THIS PERMIT is valid until

subject to the High-Speed Craft Safety Certificate remaining valid

Issued at

(Place of issue of permit)

.....

(Date of issue)

.....

(Signature of duly authorized official issuing the permit)

.....

(Seal or stamp of the issuing authority, as appropriate)

ANNEX 3

USE OF PROBABILITY CONCEPT

1 General

1.1 Absolute safety cannot be achieved in any human activity. Naturally, this fact shall be taken into account in developing safety requirements, which means that requirements shall not imply that safety is absolute. In the case of traditional craft, it has frequently been possible to specify certain aspects of design or construction in some detail, in a way which was consistent with some level of risk which had over the years been intuitively accepted without having to be defined.

1.2 For high-speed craft, however, it would often be too restrictive to include engineering specifications into the Code. Requirements therefore need to be written (where this question arises) in the sense of "... the Administration shall be satisfied on the basis of tests, investigations and past experience that the probability of --- is (acceptably low)". Since different undesirable events may be regarded as having different general orders of acceptable probability (e.g. temporary impairment of propulsion as compared with an uncontrollable fire), it is convenient to agree on a series of standardized expressions which can be used to convey the relative acceptable probabilities of various incidents, i.e. to perform a qualitative ranking process. A vocabulary is given below which is intended to ensure consistency between various requirements, where it is necessary to describe the level of risk which shall not be exceeded.

2 Terms associated with probabilities

Different undesirable events may have different orders of acceptable probability. In connection with this, it is convenient to agree on standardized expressions to be used to convey the relatively acceptable probabilities of various occurrences, i.e. to perform a qualitative ranking process.

2.1 Occurrences

2.1.1 "Occurrence" is a condition involving a potential lowering of the level of safety.

2.1.2 "Failure" is an occurrence in which a part, or parts, of the craft fail or malfunction, e.g. runaway. A failure includes:

- .1** a single failure;
- .2** independent failures in combination within a system;

- .3** independent failures in combinations involving more than one system, taking into account:
 - .3.1** any undetected failure that is already present;
 - .3.2** such further failures⁸¹ as would be reasonably expected to follow the failure under consideration; and
- .4** common cause failure (failure of more than one component or system due to the same cause).

2.1.3 "Event" is an occurrence which has its origin outside the craft (e.g. waves).

2.1.4 "Error" is an occurrence arising as a result of incorrect action by the operating crew or maintenance personnel.

2.2 Probability of occurrences

2.2.1 "Frequent" is one which is likely to occur often during the operational life of a particular craft.

2.2.2 "Reasonably probable" is one which is unlikely to occur often but which may occur several times during the total operational life of a particular craft.

2.2.3 "Recurrent" is a term embracing the total range of frequent and reasonably probable.

2.2.4 "Remote" is one which is unlikely to occur to every craft but may occur to a few craft of a type over the total operational life of a number of craft of the same type.

2.2.5 "Extremely remote" is one which is unlikely to occur when considering the total operational life of a number of craft of the type, but nevertheless shall be considered as being possible.

2.2.6 "Extremely improbable" is one which is so extremely remote that it shall not be considered as possible to occur.

2.3 Effects

2.3.1 "Effect" is a situation arising as a result of an occurrence.

⁸¹ In assessing the further failures which follow, account shall be taken of any resulting more severe operating conditions for items that have not up to that time failed.

2.3.2 "Minor effect" is an effect which may arise from a failure, an event, or an error, as defined in 2.1.2, 2.1.3, 2.1.4, which can be readily compensated for by the operating crew. It may involve:

- .1 a small increase in the operational duties of the crew or in their difficulty in performing their duties; or
- .2 a moderate degradation in handling characteristics; or
- .3 slight modification of the permissible operating conditions.

2.3.3 "Major effect" is an effect which produces:

- .1 a significant increase in the operational duties of the crew or in their difficulty in performing their duties which by itself shall not be outside the capability of a competent crew provided that another major effect does not occur at the same time; or
- .2 significant degradation in handling characteristics; or
- .3 significant modification of the permissible operating conditions, but will not remove the capability to complete a safe journey without demanding more than normal skill on the part of the operating crew.

2.3.4 "Hazardous effect" is an effect which produces:

- .1 a dangerous increase in the operational duties of the crew or in their difficulty in performing their duties of such magnitude that they cannot reasonably be expected to cope with them and will probably require outside assistance; or
- .2 dangerous degradation of handling characteristics; or
- .3 dangerous degradation of the strength of the craft; or
- .4 marginal conditions for, or injury to, occupants; or
- .5 an essential need for outside rescue operations.

2.3.5 "Catastrophic effect" is an effect which results in the loss of the craft and/or in fatalities.

2.4 Safety level

"Safety level" is a numerical value characterizing the relationship between craft performance represented as horizontal single-amplitude acceleration (g) and the severity of acceleration-load effects on standing and sitting humans.

The safety levels and the corresponding severity of effects on passengers and safety criteria for craft performance shall be as defined in table 1.

3 Numerical values

Where numerical probabilities are used in assessing compliance with requirements using the terms similar to those given above, the following approximate values may be used as guidelines to assist in providing a common point of reference. The probabilities quoted shall be on an hourly or per-journey basis, depending on which is more appropriate to the assessment in question.

Frequent	More than 10^{-3}
Reasonably probable	10^{-3} to 10^{-5}
Remote	10^{-5} to 10^{-7}
Extremely remote	10^{-7} to 10^{-9}
Extremely improbable	Whilst no approximate numerical probability is given for this, the figures used shall be substantially less than 10^{-9}

Note: Different occurrences may have different acceptable probabilities, according to the severity of their consequences (see table 2).

Table 1

EFFECT	CRITERIA NOT TO BE EXCEEDED		COMMENTS
	Type of load	Value	
LEVEL 1 MINOR EFFECT Moderate degradation of safety	Maximum acceleration measured horizontally ¹	0.20g ²	0.08g: Elderly person will keep balance when holding. 0.15g: Mean person will keep balance when holding. 0.15g: Sitting person will start holding.
LEVEL 2 MAJOR EFFECT Significant degradation of safety	Maximum acceleration measured horizontally ¹	0.35g	0.25g: Maximum load for mean person keeping balance when holding. 0.45g: Mean person falls out of seat when not wearing seat belts.
LEVEL 3 HAZARDOUS EFFECT Major degradation of safety	Collision design condition calculated Maximum structural design load, based on vertical acceleration at centre of gravity	Ref. 4.3.3 Ref. 4.3.1	Risk of injury to passengers; safe emergency operation after collision. 1.0g: Degradation of passenger safety
LEVEL 4 CATASTROPHIC EFFECT			Loss of craft or/and fatalities.

¹ The accelerometers used shall have an accuracy of at least 5% full scale and shall not have a frequency response of less than 20 Hz. The sampling frequency should not be less than 5 times the maximum frequency response. Anti-aliasing filters, if used, should have a passband equal to the frequency response.

² g = gravity acceleration (9.81 m/s²).

Table 2

SAFETY LEVEL	1	1	1	2	3	4				
EFFECT ON CRAFT AND OCCUPANTS	Normal	Nuisance	Operating limitations	Emergency procedures; significant reduction in safety margins; difficult for crew to cope with adverse conditions; passenger injuries.	Large reduction in safety margins; crew over-burden because of workload or environmental conditions; serious injury to a small number of occupants.	Deaths, usually with loss of craft				
F.A.R.¹ PROBABILITY (reference only)	←	PROBABLE	→	← IMPROBABLE →		← EXTREMELY IMPROBABLE →				
JAR-25² PROBABILITY	← FREQUENT →	PROBABLE	→ REASONABLY PROBABLE →	← IMPROBABLE →	← REMOTE →	← EXTREMELY IMPROBABLE →				
	10 ⁻⁰	10 ⁻¹	10 ⁻²	10 ⁻³	10 ⁻⁴	10 ⁻⁵	10 ⁻⁶	10 ⁻⁷	10 ⁻⁸	10 ⁻⁹
CATEGORY OF EFFECT	← MINOR →			← MAJOR →		← HAZARDOUS →		CATASTROPHIC		

¹ United States Federal Aviation Regulations.

² European Joint Airworthiness Regulations.

ANNEX 4

PROCEDURES FOR FAILURE MODE AND EFFECTS ANALYSIS

1 Introduction

1.1 In the case of traditional craft, it has been possible to specify certain aspects of design or construction in some level of detail, in a way which was consistent with some level of risk which had over the years been intuitively accepted without having to be defined.

1.2 With the development of large high-speed craft, this required experience has not been widely available. However, with the now broad acceptance of the probabilistic approach to safety assessments within industry as a whole, it is proposed that an analysis of failure performance may be used to assist in the assessment of the safety of operation of high-speed craft.

1.3 A practical, realistic and documented assessment of the failure characteristics of the craft and its component systems shall be undertaken with the aim of defining and studying the important failure conditions that may exist.

1.4 This annex describes a failure mode and effects analysis (FMEA) and gives guidance as to how it may be applied by:

- .1 explaining basic principles;
- .2 providing the procedural steps necessary to perform an analysis;
- .3 identifying appropriate terms, assumptions, measures and failure modes; and
- .4 providing examples of the necessary worksheets.

1.5 FMEA for high-speed craft is based on a single-failure concept under which each system at various levels of a system's functional hierarchy is assumed to fail by one probable cause at a time. The effects of the postulated failure are analysed and classified according to their severity. Such effects may include secondary failures (or multiple failures) at other level(s). Any failure mode which may cause a catastrophic effect to the craft shall be guarded against by system or equipment redundancy unless the probability of such failure is extremely improbable (refer to section 13). For failure modes causing hazardous effects, corrective measures may be accepted in lieu. A test programme shall be drawn to confirm the conclusions of FMEA.

1.6 Whilst FMEA is suggested as one of the most flexible analysis techniques, it is accepted that there are other methods which may be used and which in certain circumstances may offer an equally comprehensive insight into particular failure characteristics.

2 Objectives

2.1 The primary objective of FMEA is to provide a comprehensive, systematic and documented investigation which establishes the important failure conditions of the craft and assesses their significance with regard to the safety of the craft, its occupants and the environment.

2.2 The main aims of undertaking the analysis are to:

- .1 provide the Administration with the results of a study into the craft's failure characteristics so as to assist in an assessment of the levels of safety proposed for the craft's operation;
- .2 provide craft operators with data to generate comprehensive training, operational and maintenance programmes and documentation; and
- .3 provide craft and system designers with data to audit their proposed designs.

3 Scope of application

3.1 FMEA shall be conducted for each high-speed craft, before its entry into service, in respect of the systems as required under the provisions of 5.2, 9.1.10, 12.1.1 and 16.2.6 of this Code.

3.2 For craft of the same design and having the same equipment, one FMEA on the lead craft will be sufficient, but each of the craft shall be subject to the same FMEA conclusion trials.

4 System failure mode and effects analysis

4.1 Before proceeding with a detailed FMEA into the effects of the failure of the system elements on the system functional output it is necessary to perform a functional failure analysis of the craft's important systems. In this way only systems which fail the functional failure analysis need to be investigated by a more detailed FMEA.

4.2 When conducting a system FMEA the following typical operational modes within the normal design environmental conditions of the craft shall be considered:

- .1 normal seagoing conditions at full speed;
 - .2 maximum permitted operating speed in congested waters;
- and
- .3 manoeuvring alongside.

4.3 The functional interdependence of these systems shall also be described in either block diagrams or fault-tree diagrams or in a narrative format to enable the failure effects to be understood. As far as applicable, each of the systems to be analysed is assumed to fail in the following failure modes:

- .1 complete loss of function;
- .2 rapid change to maximum or minimum output;
- .3 uncontrolled or varying output;
- .4 premature operation;
- .5 failure to operate at a prescribed time; and
- .6 failure to cease operation at a prescribed time.

Depending on the system under consideration, other failure modes may have to be taken into account.

4.4 If a system can fail without any hazardous or catastrophic effect, there is no need to conduct a detailed FMEA into the system architecture. For systems whose individual failure can cause hazardous or catastrophic effects and where a redundant system is not provided, a detailed FMEA as described in the following paragraphs shall be followed. Results of the system functional failure analysis shall be documented and confirmed by a practical test programme drawn up from the analysis.

4.5 Where a system, the failure of which may cause a hazardous or catastrophic effect, is provided with a redundant system, a detailed FMEA may not be required provided that:

- .1 the redundant system can be put into operation or can take over the failed system within the time-limit dictated by the most onerous operational mode in 4.2 without hazarding the craft;
- .2 the redundant system is completely independent from the system and does not share any common system element the failure of which would cause failure of both the system and the redundant system. Common system

- element may be acceptable if the probability of failure complies with section 13; and
- .3 the redundant system may share the same power source as the system. in such case an alternative power source shall be readily available with regard to the requirement of .1.

The probability and effects of operator error to bring in the redundant system shall also be considered.

5 Equipment failure mode and effects analysis

The systems to be subject to a more detailed FMEA investigation at this stage shall include all those that have failed the system FMEA and may include those that have a very important influence on the safety of the craft and its occupants and which require an investigation at a deeper level than that undertaken in the system functional failure analysis. These systems are often those which have been specifically designed or adapted for the craft, such as the craft's electrical and hydraulic systems.

6 Procedures

The following steps are necessary to perform FMEA:

- .1 to define the system to be analysed;
- .2 to illustrate the interrelationships of functional elements of the system by means of block diagrams;
- .3 to identify all potential failure modes and their causes;
- .4 to evaluate the effects on the system of each failure mode;
- .5 to identify failure detection methods;
- .6 to identify corrective measures for failure modes;
- .7 to assess the probability of failures causing hazardous or catastrophic effects, where applicable;
- .8 to document the analysis;
- .9 to develop a test programme;
- .10 to prepare FMEA report.

7 System definition

The first step in an FMEA study is a detailed study of the system to be analysed through the use of drawings and equipment manuals. A narrative description of the system and its functional requirements shall be drawn up including the following information:

- .1 general description of system operation and structure;
- .2 functional relationship among the system elements;
- .3 acceptable functional performance limits of the system and its constituent elements in each of the typical operational modes; and
- .4 system constraints.

8 Development of system block diagrams

8.1 The next step is to develop block diagram(s) showing the functional flow sequence of the system, both for technical understanding of the functions and operation of the system and for the subsequent analysis. As a minimum the block diagram shall contain:

- .1 breakdown of the system into major sub-systems or equipment;
- .2 all appropriate labelled inputs and outputs and identification numbers by which each sub-system is consistently referenced; and
- .3 all redundancies, alternative signal paths and other engineering features which provide "fail-safe" measures.

An example of a system block diagram is given at appendix 1.

8.2 It may be necessary to have a different set of block diagrams prepared for each operational mode.

9 Identification of failure modes, causes and effects

9.1 Failure mode is the manner by which a failure is observed. It generally describes the way the failure occurs and its impact on the equipment or system. As an example, a list of failure modes is given in table 1. The failure modes listed in table 1 can describe the failure of any system element in sufficiently specific terms. When used in conjunction

with performance specifications governing the inputs and outputs on the system block diagram, all potential failure modes can be thus identified and described. Thus, for example, a power supply may have a failure mode described as "loss of output" (29), and a failure cause "open (electrical)" (31).

9.2 A failure mode in a system element could also be the failure cause of a system failure. For example, the hydraulic line of a steering gear system might have a failure mode of "external leakage" (10). This failure mode of the hydraulic line could become a failure cause of the steering gear system's failure mode "loss of output" (29).

9.3 Each system shall be considered in a top-down approach, starting from the system's functional output, and failure shall be assumed by one possible cause at a time. Since a failure mode may have more than one cause, all potential independent causes for each failure mode shall be identified.

9.4 If major systems can fail without any adverse effect there is no need to consider them further unless the failure can go undetected by an operator. To decide that there is no adverse effect does not mean just the identification of system redundancy. The redundancy shall be shown to be immediately effective or brought on line with negligible time lag. In addition, if the sequence is:

"failure - alarm - operator action - start of back up - back up in service",

the effects of delay shall be considered.

10 Failure effects

10.1 The consequence of a failure mode on the operation, function, or status of an equipment or a system is called a 'failure effect'. Failure effects on a specific sub-system or equipment under consideration are called local failure effects". The evaluation of local failure effects will help to determine the effectiveness of any redundant equipment or corrective action at that system level. In certain instances, there may not be a local effect beyond the failure mode itself.

10.2 The impact of an equipment or sub-system failure on the system output (system function) is called an "end effect". End effects shall be evaluated and their severity classified in accordance with the following categories:

- .1 catastrophic;
- .2 hazardous;

- .3 major; and
- .4 minor.

The definitions of these four categories of failure effects are given in 2.3 of annex 3 of this Code.

10.3 If the end effect of a failure is classified as hazardous or catastrophic, back-up equipment is usually required to prevent or minimize such effect. For hazardous failure effects corrective operational procedures may be accepted.

11 Failure detection

11.1 The FMEA study in general only analyses failure effects based on a single failure in the system and therefore a failure detection means, such as visual or audible warning devices, automatic sensing devices, sensing instrumentation or other unique indications shall be identified.

11.2 Where the system element failure is non-detectable (i.e. a hidden fault or any failure which does not give any visual or audible indication to the operator) and the system can continue with its specific operation, the analysis shall be extended to determine the effects of a second failure, which in combination with the first undetectable failure may result in a more severe failure effect, e.g., hazardous or catastrophic effect.

12 Corrective measures

12.1 The response of any back-up equipment, or any corrective action initiated at a given system level to prevent or reduce the effect of the failure mode of a system element or equipment, shall also be identified and evaluated.

12.2 Provisions which are features of the design at any system level to nullify the effects of a malfunction or failure, such as controlling or deactivating system elements to halt generation or propagation of failure effects, or activating back-up or standby items or systems, shall be described. Corrective design provisions include:

- .1 redundancies that allow continued and safe operation;
- .2 safety devices, monitoring or alarm provisions, which permit restricted operation or limit damage; and
- .3 alternative modes of operation.

12.3 Provisions which require operator action to circumvent or mitigate the effects of the postulated failure shall be described. The possibility and effect of operator error shall be considered, if the corrective action or the initiation of the redundancy requires operator input, when evaluating the means to eliminate the local failure effects.

12.4 It shall be noted that corrective responses acceptable in one operational mode may not be acceptable at another, e.g., a redundant system element with considerable time lag to be brought into line, while meeting the operational mode "normal seagoing conditions at full speed" may result in a catastrophic effect in another operational mode, e.g., "maximum permitted operating speed in congested water".

13 Use of probability concept

13.1 If corrective measures or redundancy as described in preceding paragraphs are not provided for any failure, as an alternative the probability of occurrence of such failure shall meet the following criteria of acceptance:

- .1 a failure mode which results in a catastrophic effect shall be assessed to be extremely improbable;
- .2 a failure mode assessed as extremely remote shall not result in worse than hazardous effects; and
- .3 a failure mode assessed as either frequent or reasonably probable shall not result in worse than minor effects.

13.2 Numerical values for various levels of probabilities are laid down in section 3 of annex 3 of this Code. In areas where there are no data from craft to determine the level of probabilities of failure other sources can be used such as:

- .1 workshop test, or
- .2 history of reliability used in other areas under similar operating conditions, or
- .3 mathematical model if applicable.

14 Documentation

14.1 It is helpful to perform FMEA on worksheet(s) as shown in appendix 2.

14.2 The worksheet(s) shall be organized to first display the highest system level and then proceed down through decreasing system levels.

15 Test programme

15.1 An FMEA test programme shall be drawn up to prove the conclusions of FMEA. It is recommended that the test programme shall include all systems or system elements whose failure would lead to:

- .1 major or more severe effects;
- .2 restricted operations; and
- .3 any other corrective action.

For equipment where failure cannot be easily simulated on the craft, the results of other tests can be used to determine the effects and influences on the systems and craft.

15.2 The trials shall also include investigations into:

- .1 the layout of control stations with particular regard to the relative positioning of switches and other control devices to ensure a low potential for inadvertent and incorrect crew action, particularly during emergencies, and the provision of interlocks to prevent inadvertent operation for important system operation;
- .2 the existence and quality of the craft's operational documentation with particular regard to the pre-voyage checklists. It is essential that these checks account for any unrevealed failure modes identified in the failure analysis; and
- .3 the effects of the main failure modes as prescribed in the theoretical analysis.

15.3 The FMEA tests on board shall be conducted in conjunction with provisions specified in 5.3, 16.4 and 17.4 of this Code, before the craft enters into service.

16 FMEA Report

The FMEA report shall be a self-contained document with a full description of the craft, its systems and their functions and the proposed operation and environmental conditions for the failure modes, causes and effects to be understood without any need to refer to other plans and documents not in the report. The analysis assumptions and system block diagrams shall be included, where appropriate. The report shall contain a summary of conclusions and recommendations for each of the systems analysed in the system failure analysis and the equipment failure analysis. It shall also list all probable failures and their probability of failure, where applicable, the

TSFS 2009:102

Bilaga 1

corrective actions or operational restrictions for each system in each of the operational modes under analysis. The report shall contain the test programme, reference any other test reports and the FMEA trials.

Appendix 1

Example of a system block diagram

Steering control system

Date

Analyst:

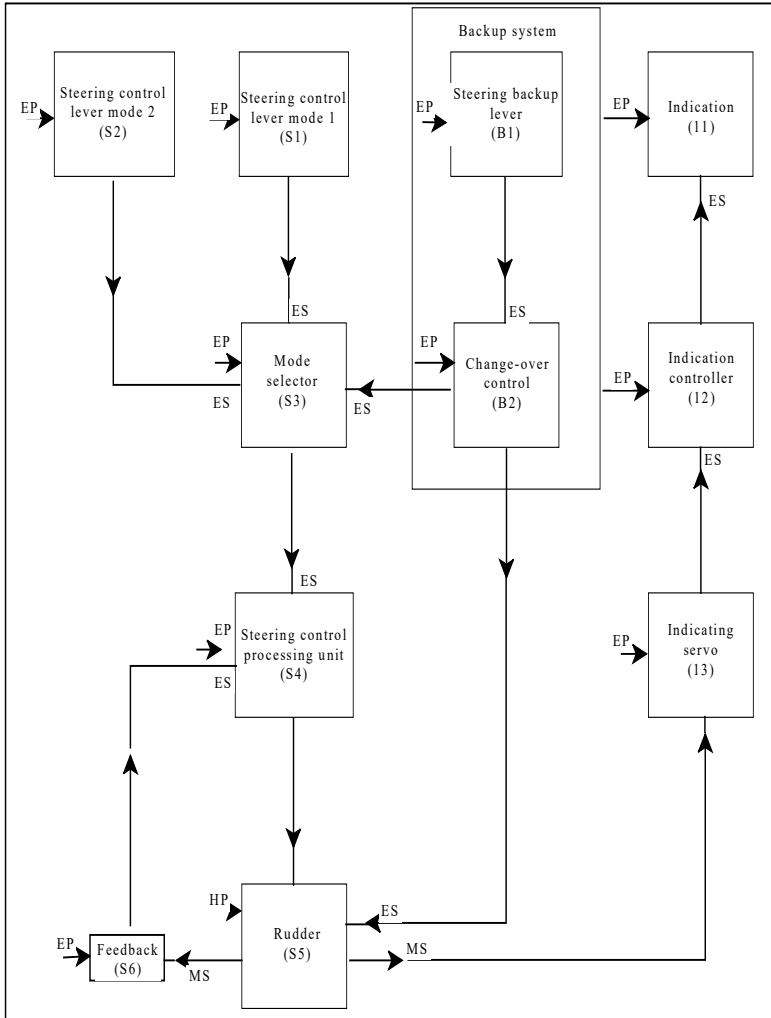

where:

- EP - electric power
- HP - hydraulic power
- ES - electric signal
- MS - mechanical signal

Table 1

Example of a set of failure modes

1	Structural failure (rupture)	19	Fails to stop
2	Physical binding or jamming	20	Fails to start
3	Vibration	21	Fails to switch
4	Fails to remain (in position)	22	Premature operation
5	Rails to open	23	Delayed operation
6	Fails to close	24	Erroneous input (increased)
7	Fails open	25	Erroneous input (decreased)
8	Fails close	26	Erroneous output (increased)
9	Internal leakage	27	Erroneous output (decreased)
10	External leakage	28	Loss of input
11	Fails out of tolerance (high)	29	Loss of output
12	Fails out of tolerance (low)	30	Shorted (electrical)
13	Inadvertent operation	31	Open (electrical)
14	Intermittent operation	32	Leakage (electrical)
15	Erratic operation	33	Other unique failure conditions as applicable to the system characteristics, requirements and operational constraints
16	Erroneous indication		
17	Restricted flow		
18	False actuation		

Refer to IEC Publication: IEC 812 (1985), Analysis techniques for system reliability - procedure for failure mode and effects analysis (FMEA).

Appendix 2

FMEA worksheet

Name of system
 Mode of operation
 Sheet No
 Date
 Name of analyst.....

References
 System block diagrams

 Drawings

Equipment name or number	Function	Ident. No.	Failure mode	Failure cause	Failure effect		Failure detection	Corrective action	Severity of failure effect	Probability of failure (if applicable)	Remarks
					Local effect	End effect					

ANNEX 5

ICE ACCRETION APPLICABLE TO ALL TYPES OF CRAFT

1 Icing allowances

1.1 For craft operating in areas where ice accretion is likely to occur, the following icing allowance shall be made in the stability calculations.

- .1 30 kg/m² on exposed weather decks and gangways;
- .2 7.5 kg/m² for projected lateral area of each side of the craft above the waterplane;
- .3 the projected lateral area of discontinuous surfaces of rail, sundry booms, spars (except masts) and rigging and the projected lateral area of other small objects shall be computed by increasing the total projected area of continuous surfaces by 5% and the static moments of this area by 10%;
- .4 reduction of stability due to asymmetric ice accumulations in cross-structure.

1.2 For craft operating in areas where ice accretion may be expected:

- .1 Within the areas defined in 2.1, 2.3, 2.4 and 2.5 known to have icing conditions significantly different from those in 1.1, ice accretion requirements of one half to twice the required allowance may be applied.
- .2 Within the area defined in 2.2, where ice accretion in excess of twice the allowance required by 1.1 may be expected, more severe requirements than those given in 1.1 may be applied.

1.3 Information shall be provided in respect of the assumptions made in calculating the condition of the craft in each of the circumstances set out in this annex for the following:

- .1 duration of the voyage in terms of the period spent in reaching the destination and returning to port; and
- .2 consumption rates during the voyage for fuel, water, stores and other consumables.

2 Areas of icing conditions

In the application of 1, the following icing areas shall apply:

- .1 The area north of latitude 65°30'N, between longitude 28°W and the west coast of Iceland; north of the north coast of Iceland;

north of the rhumb line running from latitude 66°N, longitude 15°W to latitude 73°30' N, longitude 15°E, north of latitude 73°30' N between longitude 15°E and 35°E, and east of longitude 35°E, as well as north of latitude 56°N in the Baltic Sea.
- .2 The area north of latitude 43°N bounded in the west by the North American coast and the east by the rhumb line running from latitude 43°N, longitude 48°W to latitude 63°N, longitude 28°W and thence along longitude 28°W.
- .3 All sea areas north of the North American continent, west of the areas defined in subparagraphs .1 and .2 of this paragraph.
- .4 The Bering and Okhotsk Seas and the Tartary Strait during the icing season.
- .5 South of latitude 60°S.

A chart to illustrate the areas is attached.

3 Special requirements

Craft intended for operation in areas where ice accretion is known to occur shall be:

- .1 designed to minimize the accretion of ice; and
- .2 equipped with such means for removing ice as the Administration may require.

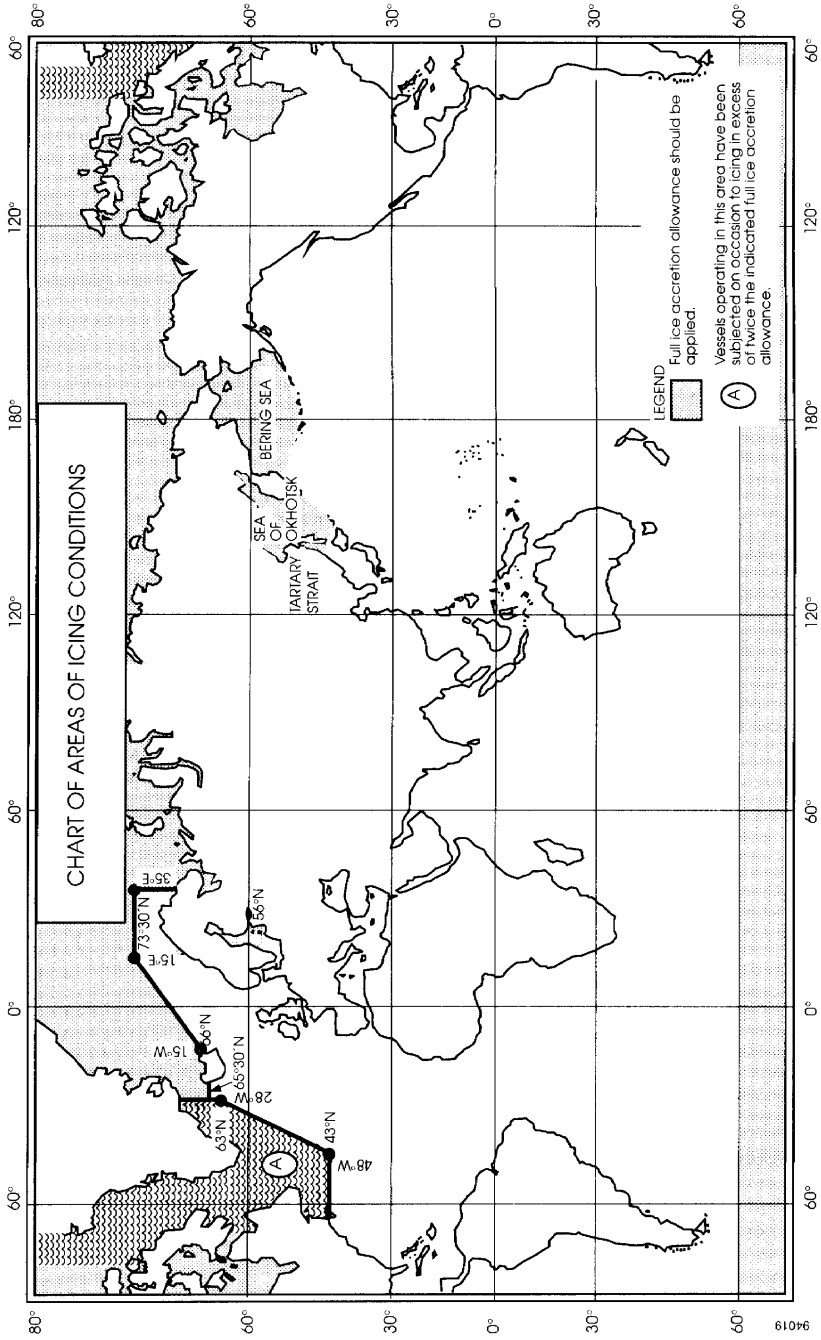

ANNEX 6

STABILITY OF HYDROFOIL CRAFT

The stability of these craft shall be considered in the hull-borne, transitional and foil-borne modes. The stability investigation shall also take into account the effects of external forces. The following procedures are outlined for guidance in dealing with stability.

As required by 2.3.1, the stability of hydrofoil craft shall be assessed under all permitted conditions of loading.

The term “hull-borne mode” has the same meaning as “displacement mode” defined in 1.4.22 of the Code.

The term “foil-borne mode” has the same meaning as “non-displacement mode” defined in 1.4.38 of the Code.

1 Surface-piercing hydrofoils

1.1 Hull-borne mode

1.1.1 The stability shall be sufficient to satisfy the provisions of 2.3, 2.4 and 2.6 of this Code.

1.1.2 Heeling moment due to turning

The heeling moment developed during manoeuvring of the craft in the displacement mode may be derived from the following formula:

$$M_R = 0.196 \frac{V_o^2}{L} \cdot \Delta \cdot KG \quad (\text{kNm})$$

where:

M_R = moment of heeling;

V_o = speed of the craft in the turn (m/s);

Δ = displacement (t);

L = length of the craft on the waterline (m);

KG = height of the centre of gravity above keel (m).

This formula is applicable when the ratio of the radius of the turning circle to the length of the craft is 2 to 4.

1.1.3 Relationship between the capsizing moment and heeling moment to satisfy the weather criterion

The stability of a hydrofoil boat in the displacement mode can be checked for compliance with the weather criterion K as follows:

$$K = \frac{M_c}{M_v} \geq 1$$

where:

M_c = minimum capsizing moment as determined when account is taken of rolling;

M_v = dynamically applied heeling moment due to the wind pressure.

1.1.4 Heeling moment due to wind pressure

The heeling moment M_V shall be taken as constant during the whole range of heel angles and calculated by the following expression:

$$M_V = 0.001 P_V A_V Z \quad (\text{kNm})$$

where :

$$P_V = \text{wind pressure} = 750 (V_w / 26)^2 \text{ (N/m}^2\text{)}$$

$$A_V = \text{windage area including the projections of the lateral surfaces of the hull, superstructure and various structures above the waterline (m}^2\text{)}$$

$$Z = \text{windage area lever (m) = the vertical distance to the geometrical centre of the windage area from the waterline}$$

$$V_w = \text{the wind speed corresponding to the worst intended conditions (m/s).}$$

1.1.5 Evaluation of the minimum capsizing moment M_c in the displacement mode

The minimum capsizing moment is determined from the static and dynamic stability curves taking rolling into account.

- .1 When the static stability curve is used, M_c is determined by equating the areas under the curves of the capsizing and righting moments (or levers) taking rolling into account, as indicated by figure 1, where θ is the amplitude of roll and MK is a line drawn parallel to the abscissa axis such that the shaded areas S_1 and S_2 are equal.

$$M_c = OM, \text{ if the scale of ordinates represents moments,}$$

$M_c = OM \times \text{displacement}$, if the scale of ordinates represents levers.

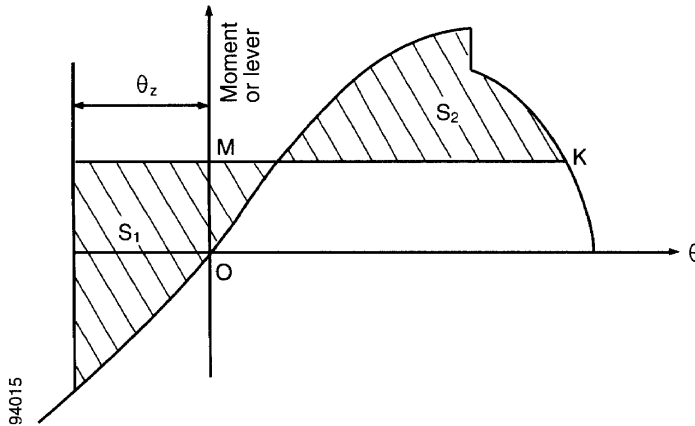

Figure 1 – Static stability curve

- 2 When the dynamic stability curve is used, first an auxiliary point A shall be determined. For this purpose the amplitude of heeling is plotted to the right along the abscissa axis and a point A' is found (see figure 2). A line AA' is drawn parallel to the abscissa axis equal to the double amplitude of heeling ($AA' = 2\theta_z$) and the required auxiliary point A is found. A tangent AC to the dynamic stability curve is drawn. From the point A the line AB is drawn parallel to the abscissa axis and equal to 1 radian (57.3°). From the point B a perpendicular is drawn to intersect with the tangent in point E. The distance \overline{BE} is equal to the capsizing moment if measured along the ordinate axis of the dynamic stability curve. If, however, the dynamic stability levers are plotted along this axis, \overline{BE} is then the capsizing lever, and in this case the capsizing moment M_c is determined by multiplication of ordinate \overline{BE} (in metres) by the corresponding displacement in tonnes

$$M_c = 9.81 \Delta \overline{BE} \quad (\text{kNm})$$

- .3 The amplitude of rolling θ_z is determined by means of model and full-scale tests in irregular seas as a maximum amplitude of rolling of 50 oscillations of a craft travelling at 90° to the wave direction in sea state for the worst design condition. If such data are lacking the amplitude is assumed to be equal to 15° .
- .4 The effectiveness of the stability curves shall be limited to the angle of flooding.

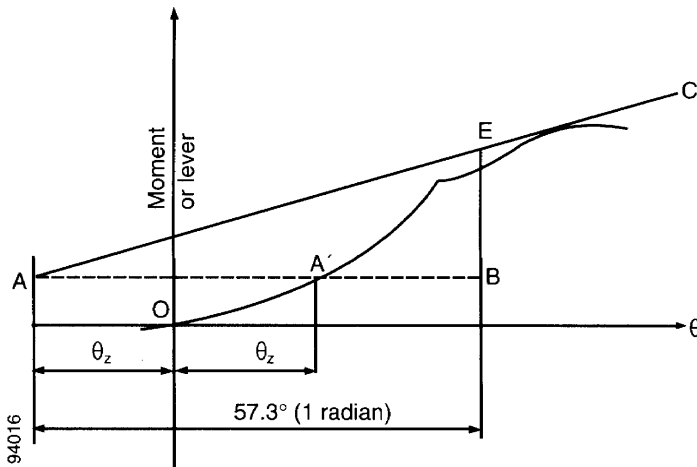

Figure 2 - Dynamic stability curve

1.2 Transitional and foil-borne modes

1.2.1 The stability shall satisfy the provisions of 2.4 and 2.5 of this Code.

1.2.2.1 The stability in the transitional and foil-borne modes shall be checked for all cases of loading for the intended service of the craft.

1.2.2.2 The stability in the transitional and foil-borne modes may be determined either by calculation or on the basis of data obtained from model experiments and shall be verified by full-scale tests by imposition of a series of known heeling moments by off-centre ballast weights, and recording the heeling angles produced by these moments. When taken in the hull-borne, take-off, steady foil-borne and settling to hull-borne modes, these results will provide an indication of the values of the stability in the various situations of the craft during the transitional condition.

1.2.2.3 The angle of heel in the foil-borne mode caused by the concentration of passengers at one side shall not exceed 8°. During the transitional mode the angle of heel due to the concentration of passengers on one side shall not exceed 12°. The concentration of passengers shall be determined by the Administration, having regard to the guidance given at annex 7 to this Code.

1.2.3 One of the possible methods of assessing foil-borne metacentric height (GM) in the design stage for a particular foil configuration is given in figure 3.

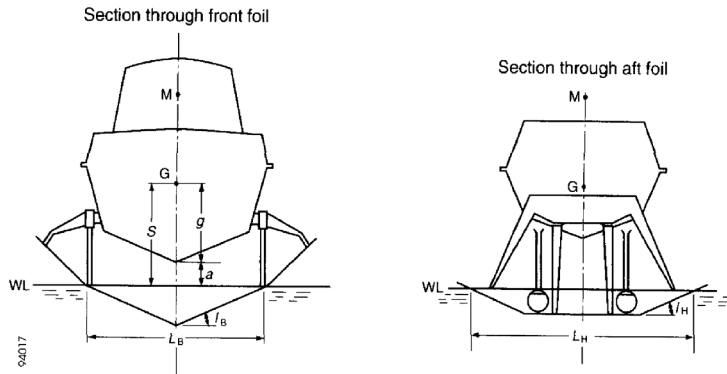

Figure 3

$$GM = n_B \left(\frac{L_B}{2 \tan I_B} - S \right) + n_H \left(\frac{L_H}{2 \tan I_H} - S \right)$$

where:

- n_B = percentage of hydrofoil load borne by front foil
- n_H = percentage of hydrofoil load borne by aft foil
- L_B = clearance width of front foil
- L_H = clearance width of aft foil
- a = clearance between bottom of keel and water
- g = height of centre of gravity above bottom of keel
- I_B = angle at which front foil is inclined to horizontal
- I_H = angle at which aft foil is inclined to horizontal
- S = height of centre of gravity above water

2 Fully submerged hydrofoils

2.1 Hull-borne mode

2.1.1 The stability in the hull-borne mode shall be sufficient to satisfy the provisions of 2.3 and 2.6 of this Code.

2.1.2 Paragraphs 1.1.2 to 1.1.5 of this annex are appropriate to this type of craft in the hull-borne mode.

2.2 Transitional mode

2.2.1 The stability shall be examined by the use of verified computer simulations to evaluate the craft's motions, behaviour and responses under the normal conditions and limits of operation and under the influence of any malfunction.

2.2.2 The stability conditions resulting from any potential failures in the systems or operational procedures during the transitional stage which could prove hazardous to the craft's watertight integrity and stability shall be examined.

2.3 Foil-borne mode

The stability of the craft in the foil-borne mode shall be in compliance with the provisions of 2.4 of this Code. The provisions of paragraph 2.2 of this annex shall also apply.

2.4 Paragraphs 1.2.2.1, 1.2.2.2 and 1.2.2.3 of this annex shall be applied to this type of craft as appropriate and any computer simulations or design calculations shall be verified by full-scale tests.

ANNEX 7

STABILITY OF MULTIHULL CRAFT

1 Stability criteria in the intact condition

A multihull craft, in the intact condition, shall have sufficient stability when rolling in a seaway to successfully withstand the effect of either passenger crowding or high-speed turning as described in 1.4. The craft's stability shall be considered to be sufficient provided compliance with this paragraph is achieved.

1.1 Area under the GZ curve

The area (A_I) under the GZ curve up to an angle θ shall be at least:

$$A_I = 0.055 \times 30^\circ / \theta \quad (\text{mrad})$$

where θ is the least of the following angles:

- .1 the downflooding angle;
- .2 the angle at which the maximum GZ occurs; and
- .3 30°

1.2 Maximum GZ

The maximum GZ value shall occur at an angle of at least 10° .

1.3 Heeling due to wind

The wind heeling lever shall be assumed constant at all angles of inclination and shall be calculated as follows:

$$HL_1 = \frac{P_i \cdot A \cdot Z}{9800\Delta} \quad (\text{m})$$

$$HL_2 = 1.5 HL_1 \quad (\text{m}) \quad (\text{see figure 1})$$

where:

$$P_i = 500 (V_w / 26)^2 \quad (\text{N/m}^2)$$

where:

V_w = wind speed corresponding to the worst intended conditions (m/s)

A = projected lateral area of the portion of the craft above the lightest service waterline (m²)

Z = vertical distance from the centre of A to a point one half the lightest service draught (m)

Δ = displacement (t)

1.4 Heeling due to passenger crowding or high-speed turning

Heeling due to the crowding of passengers on one side of the craft or to high-speed turning, whichever is the greater, shall be applied in combination with the heeling lever due to wind (HL_2).

1.4.1 Heeling due to passenger crowding

When calculating the magnitude of the heel due to passenger crowding, a passenger crowding lever shall be developed using the assumptions stipulated in 2.10 of this Code.

1.4.2 Heeling due to high-speed turning

When calculating the magnitude of the heel due to the effects of high-speed turning, a high-speed turning lever shall be developed using either the following formula or an equivalent method specifically developed for the type of craft under consideration, or trials or model test data:

$$TL = \frac{1}{g} \frac{V_o^2}{R} \left(KG - \frac{d}{2} \right) \quad (m)$$

where:

TL = turning lever (m)

V_o = speed of craft in the turn (m/s)

R = turning radius (m)

KG = height of vertical centre of gravity above keel (m)

d = mean draught (m)

g = acceleration due to gravity

Alternatively, another method of assessment may be employed, as provided for in 2.1.4 of this Code.

1.5 Rolling in waves (figure 1)

The effect of rolling in a seaway upon the craft's stability shall be demonstrated mathematically. In doing so, the residual area under the GZ curve (A_2), i.e. beyond the angle of heel (θ_h), shall be at least equal to 0.028 mrad up to the angle of roll θ_r . In the absence of model test or other data θ_r shall be taken as 15° or an angle of $(\theta_d - \theta_h)$, whichever is less. The determination of θ_r using model test or other data shall be made using the method for determining θ_Z in 1.1.5.3 of annex 6.

2 Criteria for residual stability after damage

2.1 The method of application of criteria to the residual stability curve is similar to that for intact stability except that the craft in the final condition after damage shall be considered to have an adequate standard of residual stability provided:

- .1 the required area A_2 shall be not less than 0.028 mrad (figure 2 refers); and
- .2 there is no requirement regarding the angle at which the maximum GZ value shall occur.

2.2 The wind heeling lever for application on the residual stability curve shall be assumed constant at all angles of inclination and shall be calculated as follows:

$$HL_3 = \frac{P_d \cdot A \cdot Z}{9800\Delta}$$

where:

$$P_d = 120 (V_w / 26)^2 \quad (\text{N/m}^2)$$

V_w = wind speed corresponding to the worst intended conditions (m/s)

A = projected lateral area of the portion of the ship above the lightest service waterline (m²)

Z = vertical distance from the centre of A to a point one half of the lightest service draught (m)

Δ = displacement (t)

2.3 The same values of roll angle shall be used as for the intact stability, as determined in 1.5 of this annex.

2.4 The downflooding point is important and is regarded as terminating the residual stability curve. The area A_2 shall therefore be truncated at the downflooding angle.

2.5 The stability of the craft in the final condition after damage shall be examined and shown to satisfy the criteria, when damaged as stipulated in 2.6 of this Code.

2.6 In the intermediate stages of flooding, the maximum righting lever shall be at least 0.05 m and the range of positive righting lever shall be at least 7°. In all cases, only one breach in the hull and only one free surface need to be assumed.

3 Application of heeling levers

3.1 In applying the heeling levers to the intact and damaged curves, the following shall be considered:

3.1.1 for intact condition:

- .1 wind heeling lever (including gusting effect) (HL_2); and
- .2 wind heeling lever (including gusting effect) plus either the passenger crowding or speed turning levers whichever is the greater (HTL).

3.1.2 for damage condition:

- .1 wind heeling lever - steady wind (HL_3); and
- .2 wind heeling lever plus heeling lever due to passenger crowding (HL_4)

3.2 Angles of heel due to steady wind

3.2.1 The angle of heel due to a wind gust when the heeling lever HL_2 , obtained as in 1.3, is applied to the intact stability curve shall not exceed 10° .

3.2.2 The angle of heel due to a steady wind when the heeling lever HL_3 , obtained as in 2.2, is applied to the residual stability curve after damage, shall not exceed 15° for passenger craft and 20° for cargo craft.

MULTIHULL CRAFT CRITERIA

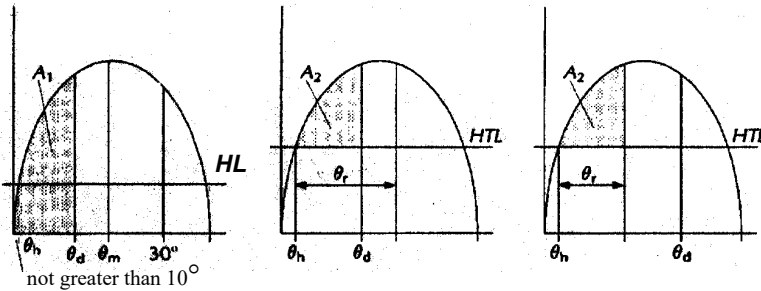

Figure 1 - Intact stability

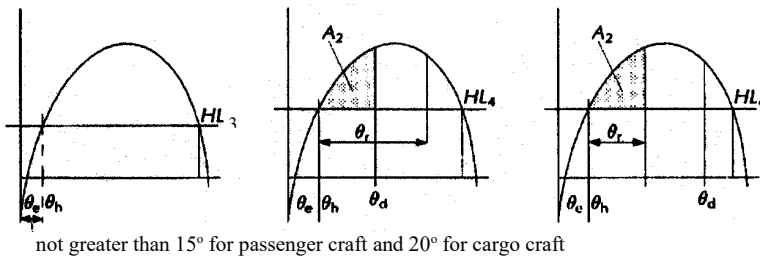

Figure 2 - Damage stability

Abbreviations used in figures 1 and 2

HL_2 = Heeling lever due to wind + gusting

HTL = Heeling lever due to wind + gusting + (passenger crowding or turning)

HL_3 = Heeling lever due to wind

HL_4 = Heeling lever due to wind + passenger crowding

θ_m = Angle of maximum GZ

θ_d = Angle of downflooding

θ_r = Angle of roll

θ_e = Angle of equilibrium, assuming no wind, passenger crowding or turning effects

θ_h = Angle of heel due to heeling lever HL_2 , HTL , HL_3 or HL_4

A_1 ≥ Area required by 1.1

A_2 ≥ 0.028 mrad

ANNEX 8

STABILITY OF MONOHULL CRAFT

1 Stability criteria in the intact condition

1.1 The weather criterion contained in paragraph 3.2 of the Intact Stability Code⁸² shall apply. In applying the weather criterion, the value of wind pressure P (N/m²) shall be taken as:

$$500 \{V_w / 26\}^2$$

where V_w = wind speed (m/s) corresponding to the worst intended conditions.

The angle of heel due to wind, in applying paragraph 3.2.2.1.2 of the Intact Stability Code, shall not exceed 16° or 80% of the angle of deck-edge 300immersion (whichever is less). Where the angle of heel due to wind exceeds 10°, efficient non-slip deck surfaces and suitable holding points shall be provided, in accordance with paragraph 2.13.1.1 of this Code. In applying the weather criterion, account shall also be taken of the roll damping characteristics of individual craft in assessing the assumed roll angle θ_1 , which may alternatively be derived from model or full scale tests using the method for determining θ_z in 1.1.5.3 of annex 6. Hulls with features which greatly increase damping, such as immersed sidehulls, substantial arrays of foils, or flexible skirts or seals, are likely to experience significantly smaller magnitudes of roll angle. For such craft, therefore, the roll angle shall be derived from model or full scale tests or, in the absence of such data, shall be taken as 15°.

1.2 The area under the righting lever curve (GZ curve) shall not be less than 0.07 mrad up to $\theta = 15^\circ$ when the maximum righting lever (GZ) occurs at $\theta = 15^\circ$, and 0.055 mrad up to $\theta = 30^\circ$ when the maximum righting lever occurs at $\theta = 30^\circ$ or above. Where the maximum righting lever occurs at angles of between $\theta = 15^\circ$ and $\theta = 30^\circ$, the corresponding area under the righting lever curve shall be:

$$A = 0.055 + 0.001 (30^\circ - \theta_{\max}) \text{ (mrad)}$$

where:

⁸² Refer to the Code on Intact Stability for All Types of Ships Covered by IMO Instruments, adopted by the Organization by resolution A.749(18), as amended by resolution MSC.75(69).

θ_{\max} is the angle of heel, in degrees, at which the righting lever curve reaches its maximum.

1.3 The area under the righting lever curve between $\theta = 30^\circ$ and $\theta = 40^\circ$ or between $\theta = 30^\circ$ and the angle of flooding θ_F ⁸³ if this angle is less than 40° , shall not be less than 0.03 mrad.

1.4 The righting lever GZ shall be at least 0.2 m at an angle of heel equal to or greater than 30° .

1.5 The maximum righting lever shall occur at an angle of heel not less than 15° .

1.6 The initial metacentric height GM_T shall not be less than 0.15 m.

2 Criteria for residual stability after damage

2.1 The stability required in the final condition after damage, and after equalization where provided, shall be determined as specified in 2.1.1 to 2.1.4.

2.1.1 The positive residual righting lever curve shall have a minimum range of 15° beyond the angle of equilibrium. This range may be reduced to a minimum of 10° , in the case where the area under the righting lever curve is that specified in 2.1.2, increased by the ratio:

$$\frac{15}{\text{range}}$$

where the range is expressed in degrees. The range shall be taken as the difference between the equilibrium heel angle and the heel angle at which the residual righting lever subsequently becomes negative or the angle at which progressive flooding occurs, whichever is less.”

2.1.2 The area under the righting lever curve shall be at least 0.015 mrad, measured from the angle of equilibrium to the lesser of:

.1 the angle at which progressive flooding occurs; and

.2 27° measured from the upright.

⁸³ In applying this criterion, small openings through which progressive flooding cannot take place need not be considered as open.

2.1.3 A residual righting lever shall be obtained within the range of positive stability, taking into account the greatest of the following heeling moments:

- .1 the crowding of all passengers towards one side;
- .2 the launching of all fully loaded davit-launched survival craft on one side; and
- .3 due to wind pressure,

as calculated by the formula:

$$GZ = \frac{\text{heeling moment}}{\text{displacement}} + 0.04 \text{ (m)}$$

However, in no case, this righting lever shall be less than 0.1 m.

2.1.4 For the purpose of calculating the heeling moments referred to in 2.1.3, the following assumptions shall be made:

- .1 Moments due to crowding of passengers. This should be calculated in accordance with paragraph 2.10 of the Code.
- .2 Moments due to launching of all fully loaded davit-launched survival craft on one side:
 - .2.1 all lifeboats and rescue boats fitted on the side to which the ship has heeled after having sustained damage shall be assumed to be swung out fully loaded and ready for lowering;
 - .2.2 for lifeboats which are arranged to be launched fully loaded from the stowed position, the maximum heeling moment during launching shall be taken;
 - .2.3 a fully loaded davit-launched liferaft attached to each davit on the side to which the ship has heeled after having sustained damage shall be assumed to be swung out ready for lowering;
 - .2.4 persons not in the life-saving appliances which are swung out shall not provide either additional heeling or righting moment; and
 - .2.5 life-saving appliances on the side of the ship opposite to the side to which the ship has heeled shall be assumed to be in a stowed position.

.3 Moments due to wind pressure:

- .3.1 the wind pressure shall be taken as $(120 \{V_w/26\}^2)$ (N/m²), where V_w = wind speed (m/s), corresponding to the worst intended condition;
- .3.2 the area applicable shall be the projected lateral area of the ship above the waterline corresponding to the intact condition; and
- .3.3 the moment arm shall be the vertical distance from a point at one half of the mean draught corresponding to the intact condition to the centre of gravity of the lateral area.

2.2 In intermediate stages of flooding, the maximum righting lever shall be at least 0.05m and the range of positive righting levers shall be at least 7°. In all cases, only one breach in the hull and only one free surface need be assumed.

ANNEX 9

DEFINITIONS, REQUIREMENTS AND COMPLIANCE CRITERIA RELATED TO OPERATIONAL AND SAFETY PERFORMANCE

This annex applies to all types of craft. Tests to evaluate operational safety shall be conducted on the first craft of a new design or of a design incorporating new features which may modify the results of a previous testing. The tests shall be carried out to a schedule agreed between the Administration and the manufacturer. Where conditions of service warrant additional testing (e.g., low temperature), the Administration or base port State authorities as appropriate may require further demonstrations. Functional descriptions, technical and system specifications relevant to the understanding and evaluation of craft performance shall be available.

The objective of these tests is to provide essential information and guidance to enable the craft to be operated safely under normal and emergency conditions within the design speed and environmental envelope.

The following procedures are outlined as requirements in dealing with verification of craft performance.

1 Performance

1.1 General

1.1.1 The craft shall meet the applicable operational requirements in chapter 17 of this Code and this annex for all extremes of passenger and load configurations for which certification is required. The limiting sea state related to the different modes of operation shall be verified by tests and analyses of a craft of the type for which certification is requested.

1.1.2 Operational control of the craft shall be in accordance with procedures established by the applicant for operation in service. Procedures to be established shall be start procedure, cruise procedures, normal and emergency stop and manoeuvre procedures.

1.1.3 The procedures established under 1.1.2 shall:

- .1 demonstrate that normal manoeuvres and craft responses to failures are consistent in performance;
- .2 use methods or devices that are safe and reliable; and
- .3 include allowance for any time lag in the execution of procedures that may reasonably be expected in service.

1.1.4 Procedures required by this annex shall be conducted over water of sufficient depth such that craft performance will not be affected.

1.1.5 Tests shall be conducted at minimum practicable weight and additional testing shall be conducted at maximum weight sufficient to establish the need for additional restrictions and for testing to examine the effect of weight.

2 Stopping

2.1 This test is to establish the acceleration experienced when stopping the craft in calm water with no passenger load or cargo load during the following conditions:

- .1 normal stop for 90% of maximum speed;
- .2 emergency stop for 90% of maximum speed; and
- .3 crash stop from 90% of maximum speed and from any transitional mode speed.

2.2 The tests referred to in 2.1.1 and 2.1.2 shall document that the accelerations do not exceed safety level 1 in annex 3 when control levers are used in accordance to written procedures as given in the craft operating manual or in an automatic mode. Should safety level 1 be exceeded during normal stop, control systems shall be modified in order to avoid exceedance or passengers shall be required to be seated during normal stop. Should safety level 1 be exceeded during emergency stop, then written procedures in the craft operating manual shall include detailed information of how to avoid exceedance or the control system shall be modified to avoid exceedance.

2.3 The test referred to in 2.1.3 shall document that the accelerations do not exceed safety level 2 in annex 3 when control levers of automatic modes are used in a manner which will give the highest accelerations. If safety level 2 is exceeded then the craft operating manual shall include a warning that it is a risk to passengers being injured, if a crash stop is performed.

2.4 Other tests shall be repeated during craft turning to establish the need or otherwise to impose any speed-related restrictions during manoeuvres.

3 Cruise performance

3.1 This test is to establish the craft performance and accelerations experienced during cruise modes with no passenger load or cargo load during the following conditions:

- .1 normal operation conditions are those in which the craft will safely cruise at any heading while manually operated, auto-pilot assisted operated or operated with any automatic control system in normal mode; and
- .2 worst intended conditions, referred to in 1.4.57 of this Code, are those in which it shall be possible to maintain safe cruise without exceptional piloting skill. However, operations at all headings relative to the wind and sea may not be possible. For type of craft having a higher performance standard in non-displacement mode, the performance and accelerations shall also be established at displacement mode during operation in the worst intended condition.

3.2 Operation levels, as defined in 3.1, shall be established and documented by full-scale tests in at least two relevant sea conditions and in head, beam and following seas. It shall be shown that the period of every test (run) and the number of series are sufficient for achieving reliable measurements. In every sea state tested, the aggregate time in each direction shall not be less than 15 min. Model tests and mathematical simulations could be used to verify the performance in the worst intended conditions.

Limits for normal operation condition shall be documented by measurements of craft speed, heading to the wave and interpolation of measurements of maximum horizontal accelerations in accordance with 2.4 of annex 3. Measurement of wave height and period shall be made to the maximum extent practicable.

Limits for worst intended condition shall be documented by measurements of craft speed, wave height and period, heading to the wave and by root mean square (RMS) values of horizontal accelerations in accordance with 2.4 of annex 3 and of vertical accelerations close to the craft longitudinal centre of gravity. RMS values could be used for extrapolation of peak values. To obtain the expected peak values related to structural design load and safety levels (one per 5-min exceedance), multiply the RMS values by 3.0 or

$$C = \sqrt{2 \ln N}$$

where:

N is the number of successive amplitudes within the relevant period.

If not otherwise verified by model tests or by mathematical calculations, it might be assumed a linear relation between wave height and accelerations based on measurements in the two sea conditions. The worst intended

conditions shall not exceed 150% of the more severe of the two measured sea conditions. Limits for worst intended condition shall be documented both related to passenger safety in accordance with 2.4 of annex 3 and related to the actual structural design load of the craft.

3.3 The tests and verification process shall document the limiting seas for safe operation of the craft:

- .1 in normal operation at 90% of maximum speed the accelerations shall not exceed safety level 1 in annex 3 with an average of one per 5-min period. The craft operating manual shall include detailed description of the effects of speed reduction or change of heading to the waves in order to prevent exceedance;
- .2 in the worst intended conditions, with reduced speed as necessary, the accelerations shall not exceed safety level 2 in annex 3 with an average of one per 5-min period, nor shall any other craft characteristic motion as pitch, roll and yaw exceed levels that could impede the safety of passengers. In worst intended conditions, with reduced speed as necessary, craft shall be safely manoeuvrable and provide adequate stability in order that the craft can continue safe operation to the nearest place of refuge, provided caution is exercised in handling. Passengers shall be required to be seated when safety level 1 in annex 3 is exceeded; and
- .3 within the actual structural design load for the craft, with reduced speed and change of heading, as necessary.

3.4 Turning and manoeuvrability

The craft shall be safely controllable and manoeuvrable during:

- .1 hull-borne operation;
- .2 operation in non-displacement mode;
- .3 take-off, landing;
- .4 any intermediate or transition modes, as applicable; and
- .5 berthing operations, as applicable.

4 Effects of failures or malfunction

4.1 General

The limits of safe operation, special handling procedures and any operational restrictions shall be examined and developed as a result of full-scale trials conducted by simulating possible equipment failures.

The failures to be examined shall be those leading to major or more severe effects as determined from evaluation of FMEA or similar analysis.

Failures to be examined shall be agreed between the craft manufacturer and the Administration and each single failure shall be examined in a progressive manner.

4.2 Objects of tests

Examination of each failure shall result in:

- .1 determining safe limits of craft operation at the time of failure, beyond which the failure will result in degradation beyond safety level 2;
- .2 determining crew member's actions, if any, to minimize or counter the effect of the failure; and
- .3 determining craft or machinery restrictions to be observed to enable the craft to proceed to a place of refuge with the failure present.

4.3 Failures to be examined

Equipment failures shall include, but not be limited to, the following:

- .1 total loss of propulsion power;
- .2 total loss of lift power (for ACV and SES);
- .3 total failure of control of one propulsion system;
- .4 involuntary application of full propulsion thrust (positive or negative) on one system;
- .5 failure of control of one directional control system;
- .6 involuntary full deflection of one directional control system;
- .7 failure of control of trim control system;
- .8 involuntary full deflection of one trim control system element; and
- .9 total loss of electrical power.

Failures shall be fully representative of service conditions and shall be simulated as accurately as possible in the most critical craft manoeuvre where the failure will have maximum impact.

4.4 "Dead ship" test

In order to establish craft motions and direction of laying to wind and waves, for the purposes of determining the conditions of a craft evacuation, the craft shall be stopped and all main machinery shut down for sufficient time that the craft's heading relative to wind and waves has stabilized. This test shall be carried out on an opportunity basis to establish patterns of the design's "dead ship" behaviour under a variety of wind and sea states.

ANNEX 10

CRITERIA FOR TESTING AND EVALUATION OF SEATS

1 Purpose and scope

The purpose of these criteria is to provide requirements for revenue and crew seats, seat anchorage and seat accessories and their installation to minimize occupant injury and/or disruption of egress/ingress if the craft suffers a collision.

2 Static seat tests

2.1 The requirements of this section are applicable to all crew and revenue seats .

2.2 All seats to which this paragraph applies, along with their supports and deck attachments, shall be designed to withstand at least the following static forces applied in the direction of the craft:

- .1 Forward direction: a force of 2.25 kN,
- .2 Aft direction: a force of 1.5 kN,
- .3 Transverse direction: a force of 1.5 kN,
- .4 Vertically downward: a force of 2.25 kN, and
- .5 Vertically upward: a force of 1.5 kN.

A seat shall comprise a frame, bottom and back. Forces applied in the fore or aft direction of the seat shall be applied horizontally to the seat back 350 mm above the seat bottom. Forces applied in the transverse seat direction shall be applied horizontally to the seat bottom. Vertical upward forces shall be evenly distributed to the corners of the seat bottom frame. Vertical downward forces shall be uniformly distributed over the seat bottom.

If a seating unit consists of more than one seating position, these forces shall be applied at each seating position concurrently during the tests.

2.3 When the forces are applied to a seat, consideration shall be given to the direction in which the seat is to face in the craft. For example, if the seat faces sideways, the transverse craft force would be applied fore and aft on the seat and the forward craft force would be applied transversely on the seat.

2.4 Each seating unit to be tested shall be attached to the support structure similar to the manner in which it will be attached to the deck

structure in the craft. Although a rigid support structure can be used for these tests, a support structure, having the same strength and stiffness as the support structure in the craft, is preferred.

2.5 The forces described in 2.2.1 to 2.2.3 shall be applied to the seat through a cylindrical surface having a radius of 80 mm and a width at least equal to the width of the seat. The surface shall be equipped with at least one force transducer able to measure the forces applied.

2.6 The seat shall be considered acceptable if:

- .1 under the influence of the forces referred to in 2.2.1 to 2.2.3, the permanent displacement measured at the point of application of the force is not more than 400 mm;
- .2 no part of the seat, the seat mountings or the accessories become completely detached during the tests;
- .3 the seat remains firmly held, even if one or more of the anchorages is partly detached;
- .4 all of the locking systems remain locked during the entire test but the adjustment and locking systems need not be operational after the tests; and
- .5 rigid parts of the seat with which the occupant may come into contact shall present a curved surface with a radius of at least 5 mm.

2.7 The requirements of section 3 may be used in lieu of the requirements of this section provided that the accelerations used for the tests are at least 3g.

3 Dynamic seat tests

3.1 The requirements of this section are applicable in addition to those in 2.1 for crew and revenue seats in craft having a design collision load of 3g or greater.

3.2 All seats for which this section applies, the seat supporting structure, the attachment to the deck structure, the lap belt, if installed, and shoulder harness, if installed, shall be designed to withstand the maximum acceleration force that can be imposed upon them during a design collision. Consideration shall be given to the orientation of the seat relative to the acceleration force (i.e. whether the seat is forward-, aft-, or side-facing).

3.3 The acceleration pulse to which the seat is subjected shall be representative of the collision time-history of the craft. If the collision time-history is not known, or cannot be simulated, the acceleration time-history envelope shown in the figure can be used.

3.4 In the test frame, each seat unit and its accessories (e.g., lap belts and shoulder harnesses) shall be attached to the support structure similar to the manner in which it will be attached in the craft. The support structure can be a rigid surface; however, a support structure having the equivalent strength and stiffness as the support structure in the craft is preferred. Other seats and/or tables with which an occupant may come in contact during a collision shall be included in the test frame in an orientation and with a method of attachment typical of that in the craft.

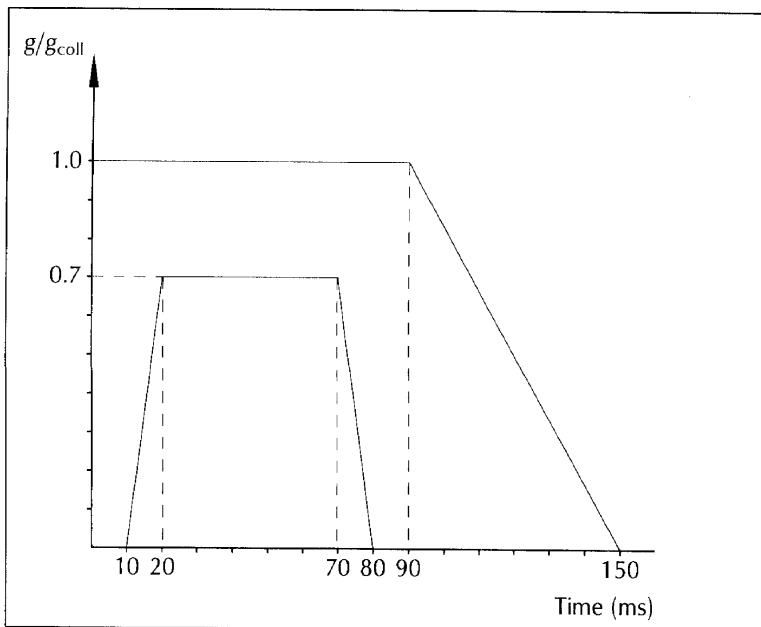

Figure - Acceleration time-history envelope

3.5 During the dynamic seat test, a fiftieth percentile anthropomorphic test dummy, suitable for the test being conducted, shall be placed in the seat in an upright seating position. If a typical seating unit is composed of more than one occupant seat, a test dummy shall be placed in each occupant seat in the unit. The dummy, or dummies, shall be secured in the seat unit in

accordance with procedures of recognized national standards⁸⁴ and be secured using only the lap belt and shoulder harness if they are installed. Tray tables and other such devices shall be placed in the position that would cause the greatest potential for an occupant to become injured.

3.6 The test dummy shall be instrumented and calibrated, in accordance with the requirements of a recognized national standard, so as to permit, as a minimum, calculation of the head injury criterion, calculation of the thoracic trauma index, measurement of force in the femur, and measurement of extension and flexion of the neck.

3.7 If more than one dummy is used in the tests, the dummy located in the seat having the highest potential for an occupant to be injured shall be the one instrumented. The other dummy or dummies need not be instrumented.

3.8 The tests shall be conducted and the instrumentation shall be sampled at a rate sufficient to reliably show response of the dummy in accordance with the requirements of a recognized national standard⁸⁵.

3.9 The seat unit tested in accordance with the requirements of this section shall be considered acceptable if:

- .1 the seat unit and tables installed in the seat unit or area do not become dislodged from the supporting deck structure and do not deform in a manner that would cause the occupant to become trapped or injured;
- .2 the lap belt, if installed, remains attached and on the test dummy's pelvis during the impact. The shoulder harness, if installed, remains attached and in the immediate vicinity of the test dummy's shoulder during the impact. After the impact, the release mechanisms of any installed lap belt and shoulder harness shall be operative;
- .3 the following acceptability criteria are met:
 - .3.1 the head injury criterion (HIC), calculated in accordance with the formula, does not exceed 500

$$\text{HIC} = (t_2 - t_1) \left[\frac{1}{t_2 - t_1} \int_{t_1}^{t_2} a(t) dt \right]^{2.5}$$

⁸⁴ Refer to ECE 80 with addendum 79. Other national standards may be acceptable.

⁸⁵ Refer to the specifications of International Standard ISO 6487 - Technique of measurement in impact tests (1987) or SAE J211 - Instrumentation.

where:

t_1 and t_2 are the beginning and ending times (in seconds) of the interval in which the HIC is a maximum. The term $a(t)$ is the resultant measured acceleration in the head of the dummy in g;

- .3.2 the thoracic trauma index (TTI), calculated in accordance with the formula, does not exceed 30g except for periods totalling less than 3 ms

$$\text{TTI} = \frac{g_R + g_{LS}}{2} \quad \text{or acceleration at the centre of gravity}$$

where:

g_R is the acceleration in g of either the upper or lower rib;

g_{LS} is the acceleration in g of the lower spine; and

- .3.3 neck flexion does not exceed 88 Nm;
- .3.4 neck extension does not exceed 48 Nm;
- .3.5 in lieu of the requirements of subparagraphs .3.3 and .3.4 above, a seatback or headrest of at least 850 mm above the seat cushion is acceptable; and
- .3.6 the force in the femur does not exceed 10 kN except that it cannot exceed 8 kN for periods totalling more than 20 ms; and
- .4 loads on the upper torso harness straps do not exceed 7.8 kN or a total of 8.9 kN if dual straps are used.

ANNEX 11

OPEN REVERSIBLE LIFERAFTS

1 General

1.1 All open reversible liferafts shall :

- .1 be constructed with proper workmanship and materials;
- .2 not be damaged in stowage throughout the air temperature range of -18°C to +65°C;
- .3 be capable of operating throughout an air temperature range of -18°C to +65°C and a seawater temperature range of -1°C to +30°C;
- .4 be rot-proof, corrosion-resistant and not be unduly affected by seawater, oil or fungal attack;
- .5 be stable and maintain their shape when inflated and fully laden; and
- .6 be fitted with retro-reflective material, where it will assist in detection, and in accordance with the recommendations adopted by the Organization⁸⁶.

2 Construction

2.1 The open reversible liferaft shall be so constructed that when it is dropped into the water in its container from a height of 10 m, the liferaft and its equipment will operate satisfactorily. If the open reversible liferaft is to be stowed at a height of more than 10 m above the waterline in the lightest seagoing condition, it shall be of a type which has been satisfactorily drop-tested from at least that height.

2.2 The open reversible floating liferaft shall be capable of withstanding repeated jumps on to it from a height of at least 4.5 m.

2.3 The open reversible liferaft and its fittings shall be so constructed as to enable it to be towed at a speed of 3 knots in calm water when loaded with its full complement of persons and equipment, with the sea-anchor deployed.

⁸⁶ Refer to the Recommendation on the Use and Fitting of Retro-Reflective Materials on Life-Saving Appliances, adopted by the Organization by resolution A.658(16).

2.4 The open reversible liferaft when fully inflated shall be capable of being boarded from the water whichever way up it inflates.

2.5 The main buoyancy chamber shall be divided into:

- .1 not less than two separate compartments, each inflated through a nonreturn inflation valve on each compartment; and
- .2 the buoyancy chambers shall be so arranged that in the event of one of the compartments being damaged or failing to inflate, the intact compartment shall be able to support, with positive freeboard over the open reversible liferaft's entire periphery, the number of persons which the liferaft is permitted to accommodate, each having a mass of 75 kg and seated in their normal positions.

2.6 The floor of the open reversible liferaft shall be waterproof.

2.7 The open reversible liferaft shall be inflated with a non-toxic gas by an inflation system complying with the requirements of paragraph 4.2.2 of the LSA Code. Inflation shall be completed within the period of one minute at an ambient temperature of between 18°C and 20°C and within a period of three minutes at an ambient temperature of -18°C. After inflation the open reversible liferaft shall maintain its form when loaded with its full complement of persons and equipment.

2.8 Each inflatable compartment shall be capable of withstanding a pressure equal to at least three times the working pressure and shall be prevented from reaching a pressure exceeding twice the working pressure either by means of relief valves or by a limited gas supply. Means shall be provided for fitting the topping-up pump or bellows.

2.9 The surface of the buoyancy tubes shall be of non-slip material. At least 25% of these tubes shall be of a highly visible colour.

2.10 The number of persons which an open reversible liferaft shall be permitted to accommodate shall be equal to the lesser of:

- .1 the greatest whole number obtained by dividing by 0.096 the volume, measured in cubic metres, of the main buoyancy tubes (which for this purpose shall not include the thwarts, if fitted) when inflated; or
- .2 the greatest whole number obtained by dividing by 0.372 the inner horizontal cross-sectional area of the open reversible liferaft measured in square metres (which for this purpose may include the thwart or thwarts, if fitted) measured to the innermost edge of the buoyancy tubes; or

- .3 the number of persons having an average mass of 75 kg, all wearing lifejackets, that can be seated inboard of the buoyancy tubes without interfering with the operation of any of the liferaft's equipment.

3 Open reversible liferaft fittings

3.1 Lifelines shall be securely becketed around the inside and outside of the open reversible liferaft.

3.2 The open reversible liferaft shall be fitted with an efficient painter of a length suitable for automatic inflation on reaching the water. For open reversible liferafts accommodating more than 30 persons an additional bowing-in line shall be fitted.

3.3 The breaking strength of the painter system, including its means of attachment to the open reversible liferaft, except the weak link required by paragraph 4.1.6.2 of the LSA Code, shall be:

- .1 7.5 kN for open reversible liferafts accommodating up to 8 persons;
- .2 10.0 kN for open reversible liferafts accommodating 9 to 30 persons; and
- .3 15.0 kN for open reversible liferafts accommodating more than 30 persons.

3.4 The open reversible liferaft shall be fitted with at least the following number of inflated ramps to assist boarding from the sea whichever way up the raft inflates:

- .1 one boarding ramp for open reversible liferafts accommodating up to 30 persons; or
- .2 two boarding ramps for open reversible liferafts accommodating more than 30 persons; such boarding ramps shall be 180° apart.

3.5 The open reversible liferaft shall be fitted with water pockets complying with the following requirements:

- .1 the cross-sectional area of the pockets shall be in the shape of an isosceles triangle with the base of the triangle attached to the buoyancy tubes of the open reversible liferaft;

- .2 the design shall be such that the pockets fill to approximately 60% of capacity within 15 s to 25 s of deployment;
- .3 the pockets attached to each buoyancy tube shall normally have aggregate capacity of between 125 l and 150 l for inflatable open reversible liferafts up to and including the 10-person size;
- .4 the pockets to be fitted to each buoyancy tube on liferafts certified to carry more than 10 persons shall have, as far as practicable, an aggregate capacity of 12 *N* litres, where *N* is the number of persons carried;
- .5 each pocket on a buoyancy tube shall be attached so that when the pocket is in the deployed position it is attached along the full length of its upper edges to, or close to, the lowest part of the lower buoyancy tube; and
- .6 the pockets shall be distributed symmetrically round the circumference of the liferaft with sufficient separation between each pocket to enable air to escape readily.

3.6 At least one manually controlled lamp complying with the requirements shall be fitted on the upper and lower surfaces of the buoyancy tubes.

3.7 Suitable automatic drain arrangements shall be provided on each side of the floor of the liferaft in the following manner:

- .1 one for open reversible liferafts accommodating up to 30 persons; or
- .2 two for open reversible liferafts accommodating more than 30 persons.

3.8 The equipment of every open reversible liferaft shall consist of:

- .1 one buoyant rescue quoit, attached to not less than 30 m of buoyant line with a breaking strength of at least 1 kN;
- .2 two safety knives of the non-folding type, having a buoyant handle, shall be fitted attached to open reversible liferaft by light lines. They shall be stowed in pockets so that, irrespective of the way in which the open reversible liferaft inflates, one will be readily available on the top surface of the upper buoyancy tube in a suitable position to enable the painter to be readily cut;
- .3 one buoyant bailer;

- .4 two sponges;
- .5 one sea-anchor permanently attached to the open reversible liferaft in such a way as to be readily deployable when the open reversible liferaft inflates. The position of the sea-anchor shall be clearly marked on both buoyancy tubes;
- .6 two buoyant paddles;
- .7 one first-aid outfit in a waterproof case capable of being closed tightly after use;
- .8 one whistle or equivalent sound signal;
- .9 two hand flares;
- .10 one waterproof electric torch suitable for Morse signalling together with one spare set of batteries and one spare bulb in a waterproof container;
- .11 one repair outfit for repairing punctures in buoyancy compartments; and
- .12 one topping-up pump or bellows.

3.9 The equipment specified in 3.8 is designated an HSC Pack.

3.10 Where appropriate, the equipment shall be stowed in a container which, if it is not an integral part of, or permanently attached to, the open reversible liferaft, shall be stowed and secured to the open reversible liferaft and be capable of floating in water for at least 30 min without damage to its contents. Irrespective of whether the equipment container is an integral part of, or is permanently attached to, the open reversible liferaft, the equipment shall be readily accessible irrespective of which way up the open reversible liferaft inflates. The line which secures the equipment container to the open reversible liferaft shall have a breaking strength of 2 kN or a breaking strength of 3:1 based on the mass of the complete equipment pack, whichever is the greater.

4 Containers for open reversible inflatable liferafts

- 4.1 The open reversible liferafts shall be packed in a container that is:
- .1 so constructed as to withstand conditions encountered at sea;
 - .2 of sufficient inherent buoyancy, when packed with the liferaft and its equipment, to pull the painter from within and to operate the inflation mechanism shall the craft sink; and
 - .3 as far as practicable, watertight, except for drain holes in the container bottom.

- 4.2 The container shall be marked with:
- .1 maker's name or trademark;
 - .2 serial number;
 - .3 the number of persons it is permitted to carry;
 - .4 non-SOLAS reversible;
 - .5 type of emergency pack enclosed;
 - .6 date when last serviced;
 - .7 length of painter;
 - .8 maximum permitted height of stowage above waterline (depending on drop-test height); and
 - .9 launching instructions.

5 Markings on open reversible inflatable liferafts

The open reversible liferafts shall be marked with:

- .1 maker's name or trademark;
- .2 serial number;
- .3 date of manufacture (month and year);
- .4 name and place of service station where it was last serviced; and
- .5 number of persons it is permitted to accommodate on the top of each buoyancy tube, in characters not less than 100 mm in height and of a colour contrasting with that of the tube.

6 Instructions and information

Instructions and information required for inclusion in the craft's training manual and in the instructions for on-board maintenance shall be in a form suitable for inclusion in such training manual and instructions for on-board maintenance. Instructions and information shall be in a clear and concise form and shall include, as appropriate, the following:

- .1 general description of the open reversible liferaft and its equipment;
- .2 installation arrangements;
- .3 operational instructions, including use of associated survival equipment; and
- .4 servicing requirements.

7 Testing of open reversible inflatable liferafts

7.1 When testing open reversible liferafts in accordance with the recommendations of resolution MSC.81(70), part 1:

- .1 tests No. 5.5, 5.12, 5.16, 5.17.2, 5.17.10, 5.17.11, 5.17.12, 5.18 and 5.20 may be omitted;
- .2 the part of test No. 5.8 regarding closing arrangement may be omitted,
- .3 the temperature – 30°C in test No. 5.17.3 and 5.17.5 may be substituted with - 18°C; and
- .4 the drop height of 18 m in test No. 5.1.2 may be substituted with 10 m.

Omittances and substitution, as described above, shall be reflected in the type approval certificate.

ANNEX 12

FACTORS TO BE CONSIDERED IN DETERMINING CRAFT OPERATING LIMITATIONS⁸⁷

1 Purpose and scope

The purpose of this annex is to identify the parameters to which consideration should be given when determining the worst intended conditions (defined in 1.4.61) and other operational limitations (defined in 1.4.41) for insertion into the Permit to Operate, in order to facilitate consistent application of the Code.

2 Factors to be considered

As a minimum, the following factors shall be considered:

- .1 The maximum distance from refuge implied by 1.3.4.
- .2 The availability of rescue resources to comply with 1.4.12.1 (category A craft only).
- .3 Minimum air temperature (susceptibility to icing), visibility and depth of water for safe operation as addressed by 1.4.61.
- .4 The significant wave height and maximum mean wind speed used when applying the requirements for stability and buoyancy in chapter 2 and associated annexes.
- .5 The safe seakeeping limitations (especially significant wave height) considering the known stability hazards listed in 2.1.5, the operating conditions on the intended route (see 18.1.3.2) and the motions experienced during operation defined in 3.3 of annex 9.
- .6 The structural safety of the craft in critical design conditions according to chapter 3.
- .7 The safe deployment and operation of evacuation systems and survival craft as required by 8.6.5.
- .8 The safe handling limitations determined in accordance with the sea trials required by chapter 17 and annexes 3 and 9, identifying any limitations on weight and centre-of-gravity position according to 17.3, and the effects of failures and malfunctions according to 17.4.

⁸⁷ Refer to the guidelines to be developed by the Organization.

Bilaga 2

RESOLUTION MSC.97(73) *(adopted on 5 December 2000)*

ADOPTION OF THE INTERNATIONAL CODE OF SAFETY FOR HIGH-SPEED CRAFT, 2000 (2000 HSC CODE)

THE MARITIME SAFETY COMMITTEE,

RECALLING Article 28(b) of the Convention on the International Maritime Organization concerning the functions of the Committee,

NOTING the International Code for the Safety of High-Speed Craft (1994 HSC Code) and chapter X of the International Convention for the Safety of Life at Sea (SOLAS), 1974 (hereinafter referred to as "the Convention"), which made the 1994 HSC Code mandatory under the Convention,

RECOGNIZING that development of novel types and sizes of high-speed craft and improvements of maritime safety standards since the adoption of the 1994 HSC Code necessitate the revision of the provisions for the design, construction, equipment and operation of high-speed craft in order to maintain the highest practical level of safety,

NOTING ALSO resolution MSC.99(73) by which it adopted amendments to chapter X of the Convention to make the provisions of the International Code for the Safety of High-Speed Craft, 2000 (2000 HSC Code) mandatory under the Convention for high-speed craft constructed on or after 1 July 2002,

HAVING CONSIDERED, at its seventy-third session, the text of the draft 2000 HSC Code which has been developed following a thorough revision of the 1994 HSC Code,

1. ADOPTS the International Code of Safety for High-Speed Craft, 2000 (2000 HSC Code), the text of which is set out in the Annex to the present resolution;
2. INVITES Contracting Governments to the Convention to note that the 2000 HSC Code will take effect on 1 July 2002 upon entry into force of the amendments to chapter X of the Convention;
3. REQUESTS the Secretary-General to transmit certified copies of the present resolution and the text of the 2000 HSC Code contained in the Annex to all Contracting Governments to the Convention;
4. FURTHER REQUESTS the Secretary-General to transmit copies of this resolution and the Annex to all Members of the Organization which are not Contracting Governments to the Convention.

